

AMENDED PUBLIC WORKS STANDARDS, STREET DESIGN CRITERIA,

SECTION 14, DRIVEWAYS

January, 2004

14. DRIVEWAYS

| | Maximum* | Minimum* | Thickness |
|------------------|--------------------------------|----------|--------------------|
| Commercial | 52 feet | 30 feet | 5-1/2" or 9" PCC** |
| Residential | 30 feet | 12 feet | 5-1/2" PCC |
| Maximum Frontage | Residential – 40% | | |
| | Commercial & Industrial – 30 % | | |

*Clear width measured at bottom of transition.

**The 5-1/2 inch thick commercial driveway must be steel reinforced.

- A. Minimum clear distance between driveways on same property – two feet.
- B. Minimum clear distance from property line – three feet, unless joint driveway over property line is used.
- C. Minimum distance from curb return – 0 feet – no encroachment.
- D. Minimum distance from fire hydrant, utility or street light pole – three feet.

All dimensions are to top of transition unless otherwise noted.

- E. Alley Apron (PW-21) shall be use when the following conditions:
 - 1. When the development is commercial, industrial, or multiple residential and fronts on a Circulation Element Street.
 - 2. When the development is commercial, industrial, or multiple residential and fronts on any street having a current or projected Average Daily Traffic volume of 5,000 or greater.

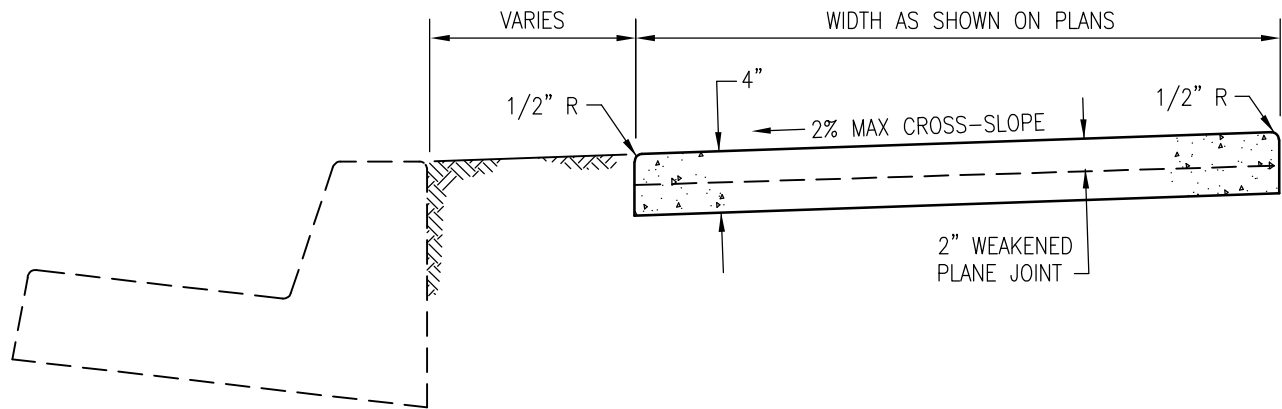

NON-CONTIGUOUS

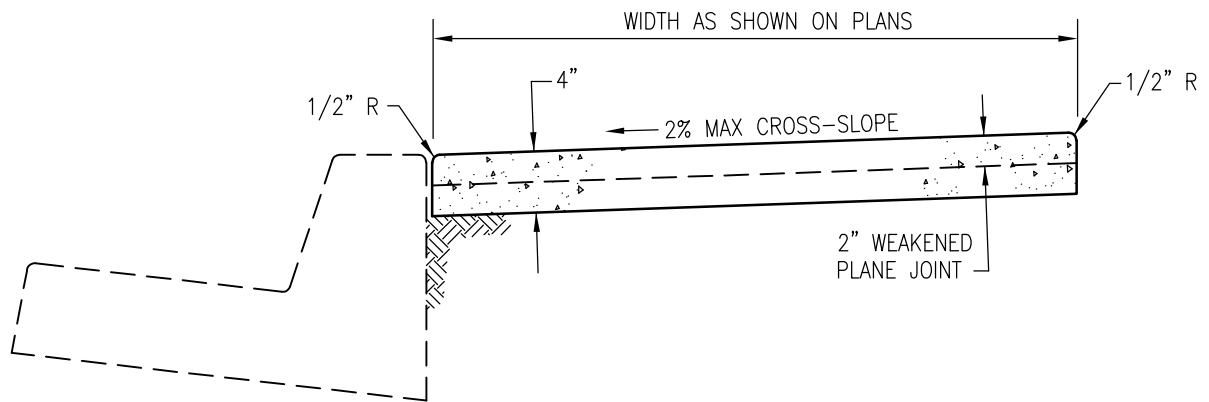

CONTIGUOUS

NOTES:

1. CONCRETE SHALL BE 520-C-2500.
2. SEE STANDARD DRAWINGS G-9 AND G-10 FOR JOINT DETAILS.

LEGEND ON PLANS

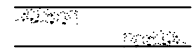

| Revision | By | Approved | Date |
|----------|----|------------|-------|
| ORIGINAL | | KERCHEVAL | 12/75 |
| REVIEWED | CV | CV | 12/15 |
| Reviewed | KE | S. Stanton | 10/18 |
| Reviewed | RP | S. Engeda | 03/22 |

SAN DIEGO REGIONAL STANDARD DRAWING

SIDEWALK - TYPICAL SECTIONS

RECOMMENDED BY THE SAN DIEGO REGIONAL STANDARDS COMMITTEE

Samantha Engeda 03/24/2022
Chairperson R.C.E. 52241 Date

DRAWING NUMBER **G-07**

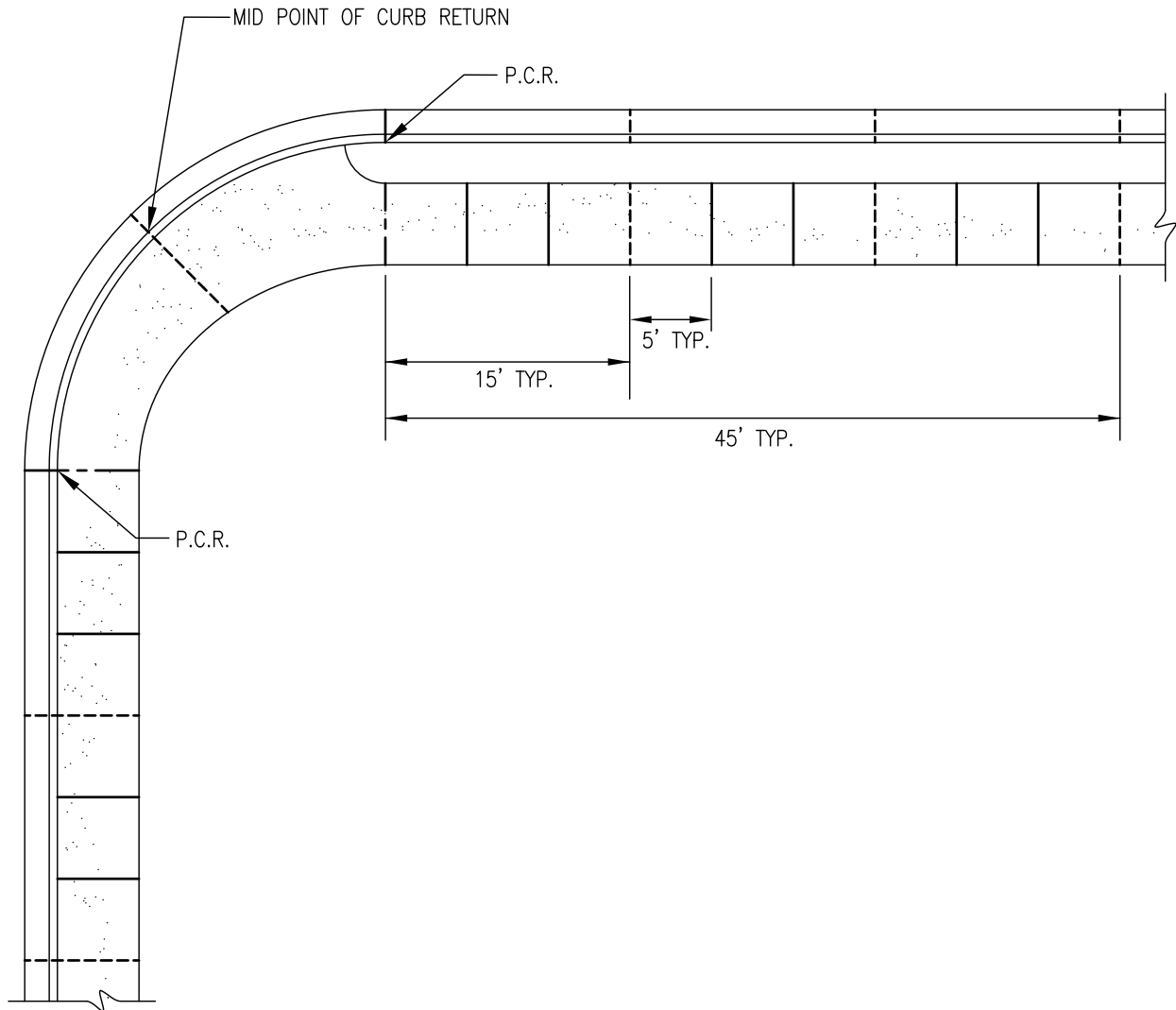

NOTES:

1. EXPANSION JOINTS AT CURB RETURNS, ADJACENT TO STRUCTURES AND AT 45' INTERVALS. (SEE STANDARD DRAWING G-10).
2. WEAKENED PLANE JOINTS AT MID POINT OF CURB RETURN, WHEN REQUIRED, AND AT 15' INTERVALS FROM P.C.R. (SEE STANDARD DRAWING G-10).
3. 1/4" GROOVES WITH 1/4" RADIUS EDGES AT 5' INTERVALS.

| Revision | By | Approved | Date |
|-------------|----|------------|-------|
| ORIGINAL | | KERCHEVAL | 12/75 |
| REFORMATTED | | T. STANTON | 04/06 |
| REVIEWED | CV | CV | 12/15 |
| REVIEWED | RP | S. Engeda | 03/22 |

SAN DIEGO REGIONAL STANDARD DRAWING

SIDEWALK JOINT LOCATIONS

RECOMMENDED BY THE SAN DIEGO REGIONAL STANDARDS COMMITTEE

03/24/2022
 Chairperson R.C.E. 52241 Date

DRAWING NUMBER G-09

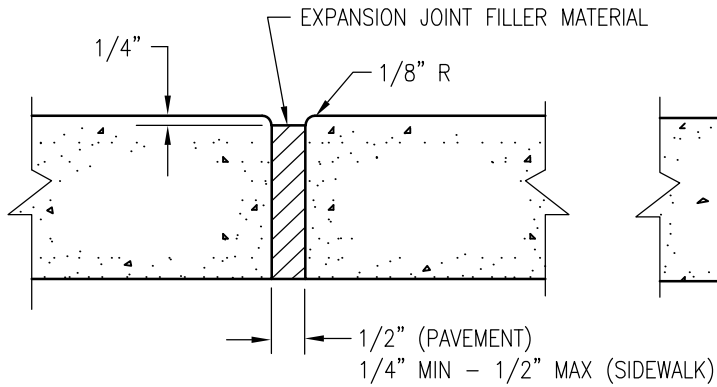

EXPANSION JOINT

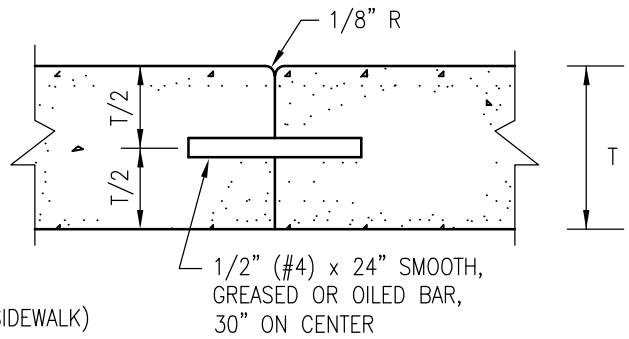

CONTACT JOINT

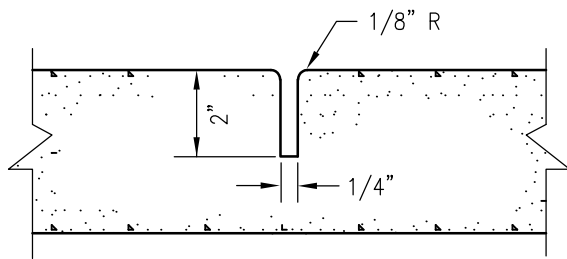

WEAKENED PLANE JOINT
CURB AND SIDEWALK

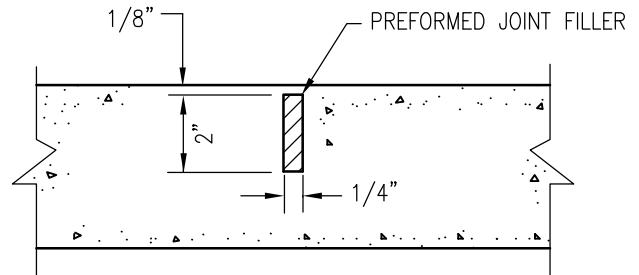

WEAKENED PLANE JOINT
GUTTER AND CONCRETE PAVEMENT

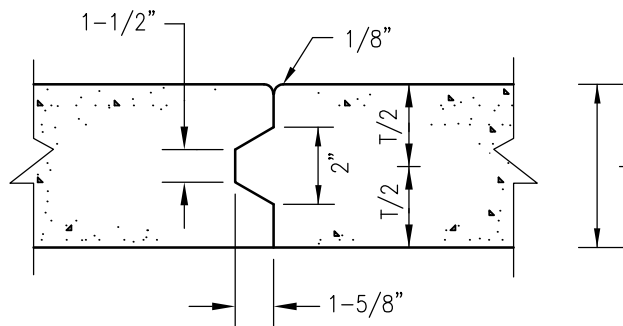

KEYED JOINT

| Revision | By | Approved | Date |
|----------|----|-----------|-------|
| ORIGINAL | | PARKINSON | 02/95 |
| UPDATED | CV | MR/CV | 11/11 |
| REVIEWED | CV | CV | 12/15 |
| Reviewed | RP | S. Engeda | 03/22 |

SAN DIEGO REGIONAL STANDARD DRAWING

CONCRETE JOINT DETAILS

RECOMMENDED BY THE SAN DIEGO REGIONAL STANDARDS COMMITTEE

Somson Engeda 03/24/2022
Chairperson R.C.E. 52241 Date

DRAWING NUMBER **G-10**

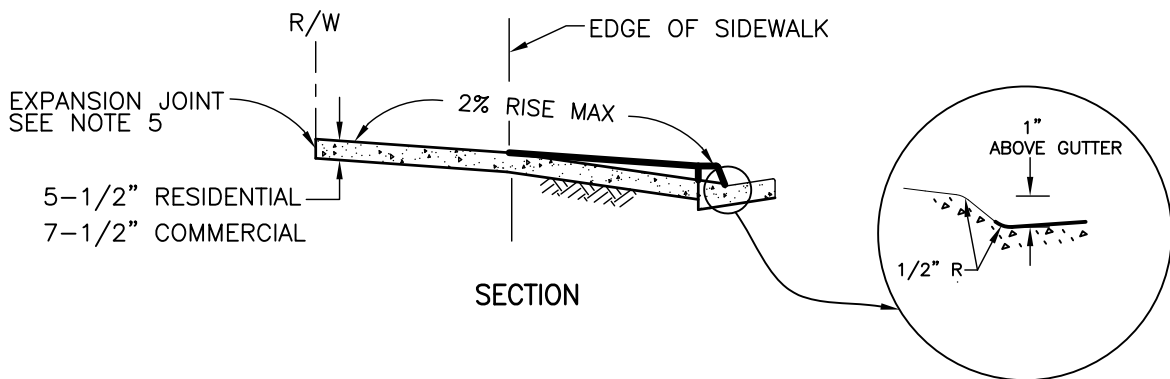
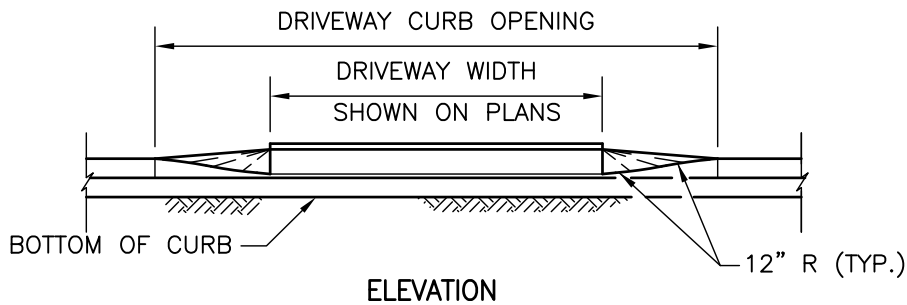
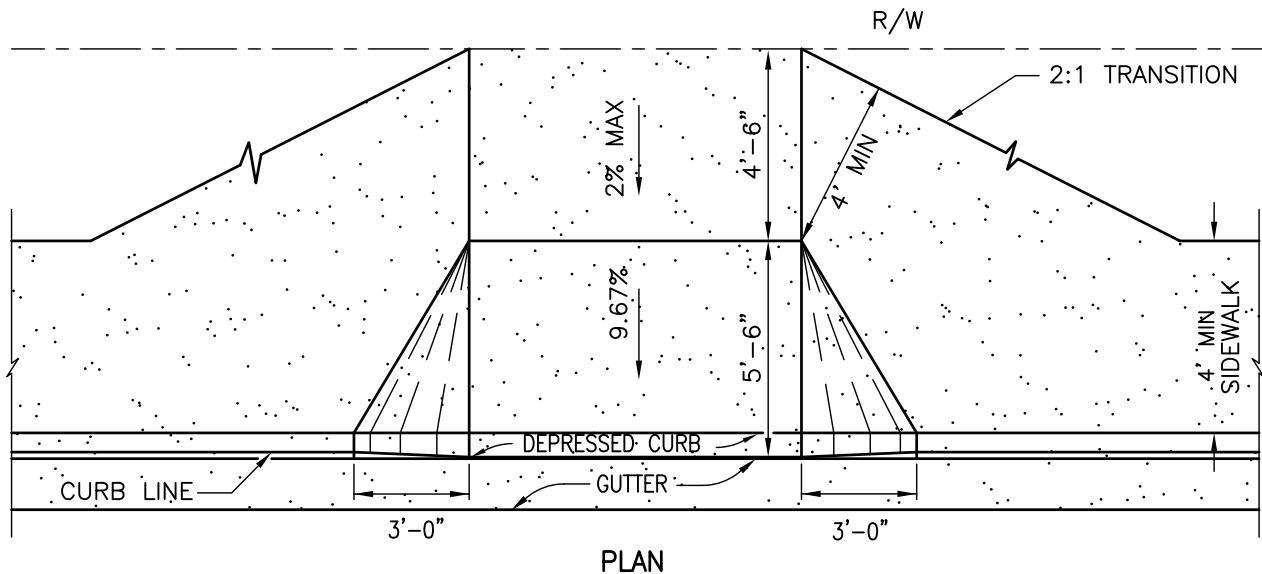

NOTES:

1. NO CONCRETE SHALL BE PLACED UNTIL FORMS AND SUBGRADE ARE INSPECTED BY THE AGENCY.
2. FOR RESIDENTIAL USE, CONCRETE SHALL BE 520-C-2500; FOR COMMERCIAL USE, CONCRETE SHALL BE 560-C-3250.
3. SEE STANDARD DRAWINGS G-15 AND G-16 FOR WIDTH AND LOCATION REQUIREMENTS.
4. DRIVEWAY RAMP TO EXTEND 10' FROM CURB FACE OR TO PROPERTY LINE WHICHEVER IS LESS.
5. PLACE EXPANSION JOINT AT RIGHT-OF-WAY OR 10' WHICHEVER IS LESS.
6. SEE STANDARD DRAWINGS G-2 AND G-10 FOR CURB AND JOINT DETAILS.
7. DIMENSIONS SHOWN REFLECT A 6" CURB HEIGHT.

| Revision | By | Approved | Date |
|----------|----|-----------|-------|
| ORIGINAL | | R. MUNOZ | 4/97 |
| UPDATED | MR | MR/CV | 02/12 |
| UPDATED | CV | CV | 12/15 |
| Reviewed | RP | S. Engeda | 03/22 |

SAN DIEGO REGIONAL STANDARD DRAWING

**CONCRETE DRIVEWAY - TYPE A
(CONTIGUOUS SIDEWALK)**

RECOMMENDED BY THE SAN DIEGO REGIONAL STANDARDS COMMITTEE

Samantha Engeda 03/24/2022
Chairperson R.C.E. 52241 Date

DRAWING NUMBER **G-14A**

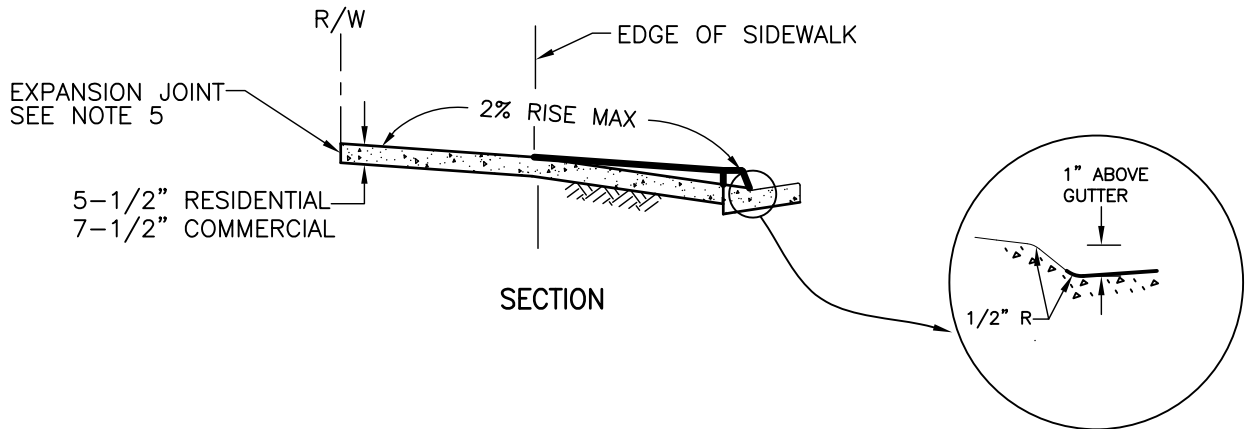
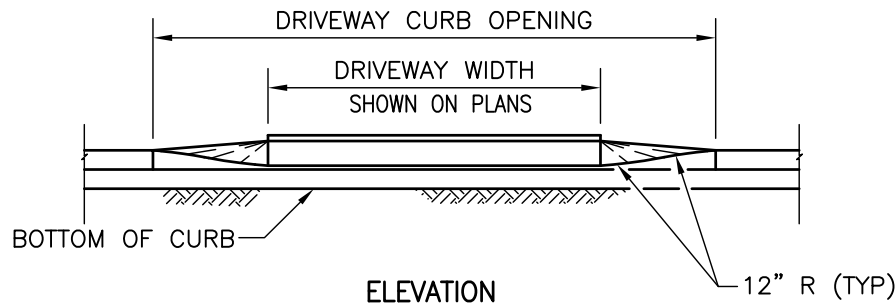
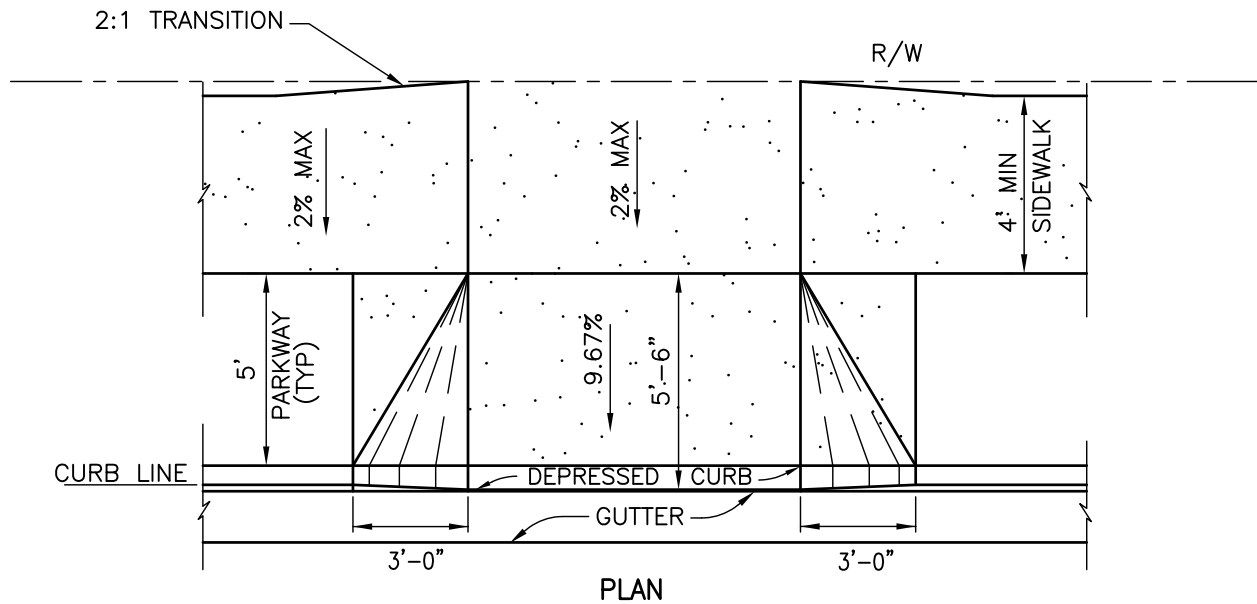

NOTES:

1. NO CONCRETE SHALL BE PLACED UNTIL FORMS AND SUBGRADE ARE INSPECTED BY THE AGENCY.
2. FOR RESIDENTIAL USE, CONCRETE SHALL BE 520-C-2500; FOR COMMERCIAL USE, CONCRETE SHALL BE 560-C-3250.
3. SEE STANDARD DRAWINGS G-15 AND G-16 FOR WIDTH AND LOCATION REQUIREMENTS.
4. DRIVEWAY RAMP TO EXTEND TO 10' FROM CURB FACE OR TO PROPERTY LINE WHICHEVER IS LESS.
5. PLACE EXPANSION JOINT AT RIGHT-OF-WAY OR 10', WHICHEVER IS LESS.
6. SEE STANDARD DRAWINGS G-2 AND G-10 FOR CURB AND JOINT DETAILS.
7. DIMENSIONS SHOWN REFLECT A 6" CURB HEIGHT.

| Revision | By | Approved | Date |
|----------|----|-----------|-------|
| ORIGINAL | | R. MUNOZ | 4/97 |
| UPDATED | MR | MR/CV | 02/12 |
| UPDATED | CV | CV | 12/15 |
| Reviewed | RP | S. Engeda | 03/22 |

SAN DIEGO REGIONAL STANDARD DRAWING

**CONCRETE DRIVEWAY
(NON-CONTIGUOUS SIDEWALK)**

RECOMMENDED BY THE SAN DIEGO REGIONAL STANDARDS COMMITTEE

Samantha Engeda 03/24/2022
Chairperson R.C.E. 52241 Date

DRAWING NUMBER **G-14B**

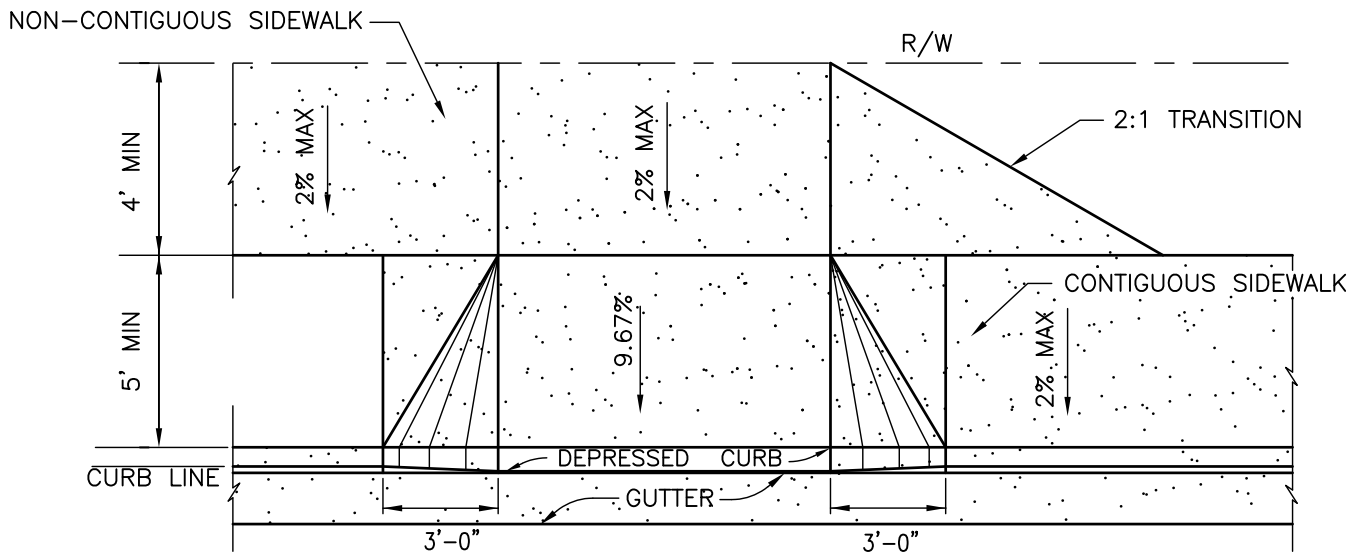

PLAN

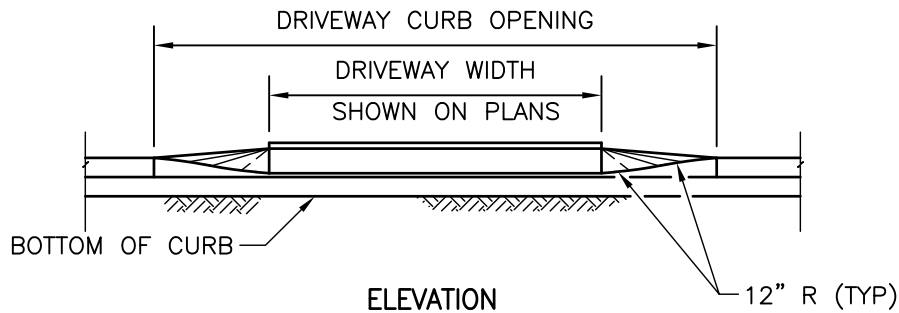

ELEVATION

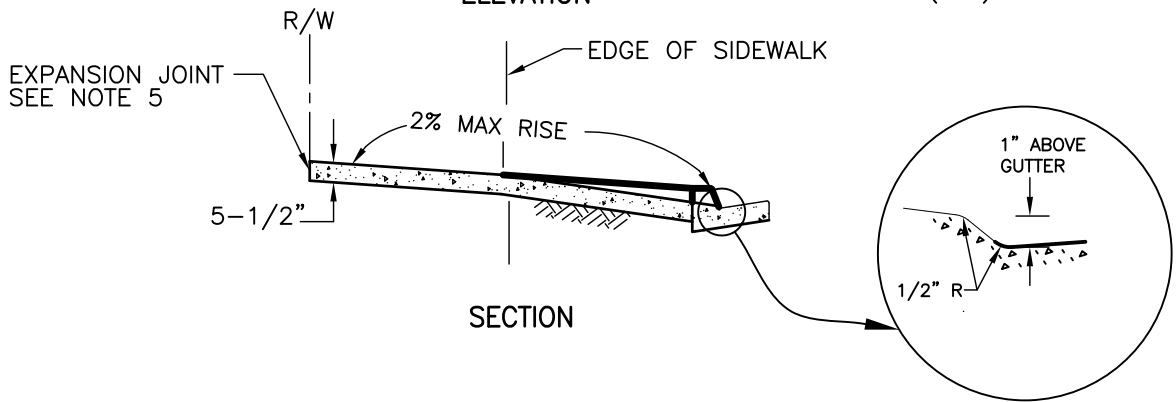

SECTION

NOTES:

1. NO CONCRETE SHALL BE PLACED UNTIL FORMS AND SUBGRADE ARE INSPECTED BY THE AGENCY.
2. CONCRETE SHALL BE 520-C-2500.
3. SEE STANDARD DRAWINGS G-15 AND G-16 FOR WIDTH AND LOCATION REQUIREMENTS.
4. DRIVEWAY RAMP TO EXTEND 10' FROM FACE OF CURB OR TO PROPERTY LINE WHICHEVER IS LESS.
5. PLACE EXPANSION JOINT AT RIGHT-OF-WAY OR 10', WHICHEVER IS LESS.
6. SEE STANDARD DRAWINGS G-2 AND G-10 FOR CURB AND JOINT DETAILS.
7. DIMENSIONS SHOWN REFLECT A 6" CURB HEIGHT.

| Revision | By | Approved | Date |
|----------|----|-----------|-------|
| ORIGINAL | | R. MUNOZ | 4/97 |
| UPDATED | MR | MR/CV | 02/12 |
| UPDATED | CV | CV | 12/15 |
| Reviewed | RP | S. Engeda | 03/22 |

SAN DIEGO REGIONAL STANDARD DRAWING

**RESIDENTIAL
CONCRETE DRIVEWAY
(PARKWAY LESS THAN 10' IN DEPTH)**

RECOMMENDED BY THE SAN DIEGO REGIONAL STANDARDS COMMITTEE

Somayr Engeda 03/24/2022
Chairperson R.C.E. 52241 Date

DRAWING NUMBER G-14C

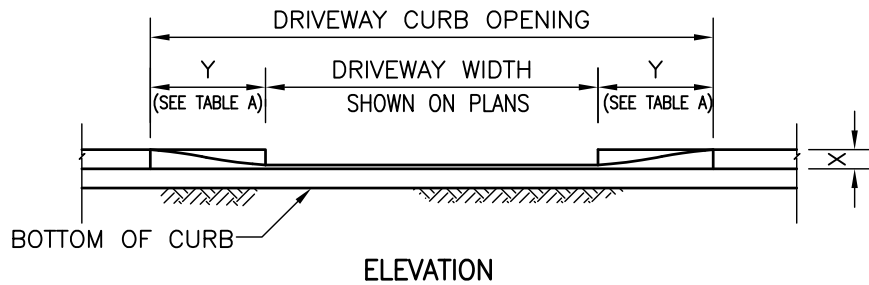
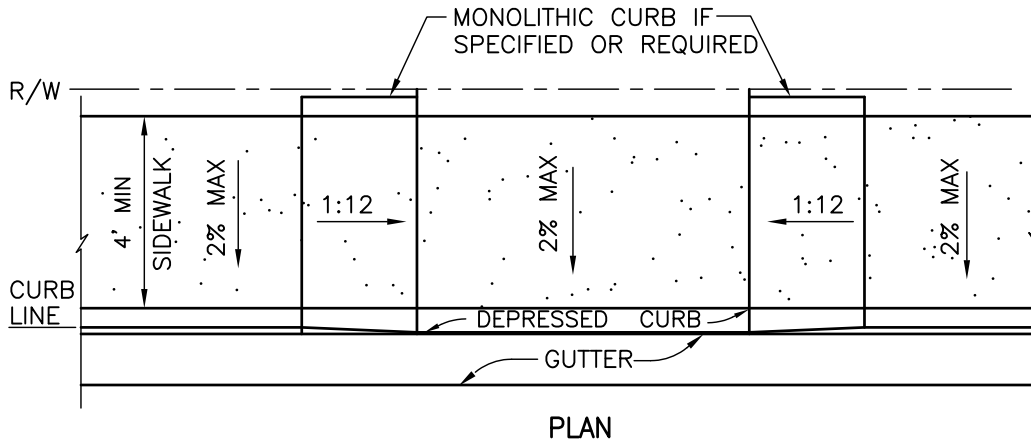

| TABLE A | |
|-------------|-------------|
| X | Y |
| CURB HEIGHT | RAMP LENGTH |
| 1" | 0'-0" |
| 2" | 1'-0" |
| 3" | 2'-0" |
| 4" | 3'-0" |
| 5" | 4'-0" |
| 6" | 5'-0" |
| 7" | 6'-0" |
| 8" | 7'-0" |

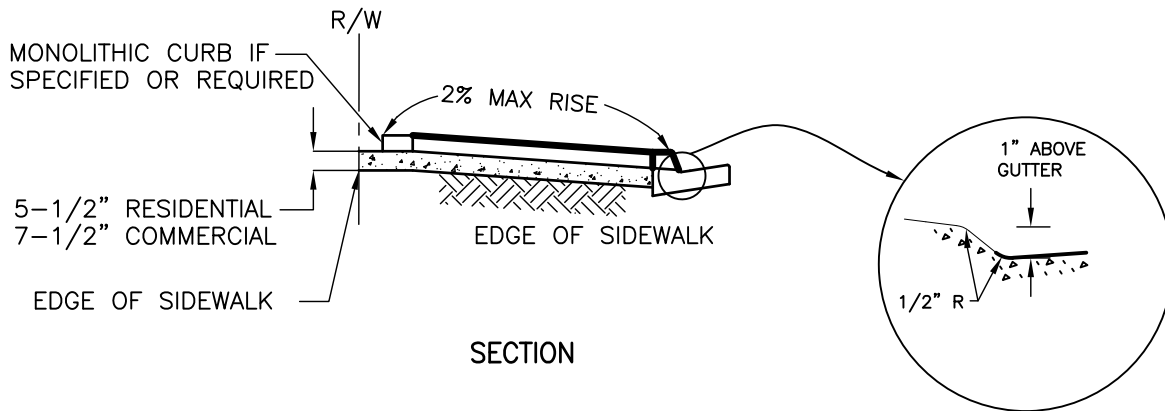

NOTES:

1. NO CONCRETE SHALL BE PLACED UNTIL FORMS AND SUBGRADE ARE INSPECTED BY THE AGENCY.
2. FOR RESIDENTIAL USE, CONCRETE SHALL BE 520-C-2500; FOR COMMERCIAL USE, CONCRETE SHALL BE 560-C-3250.
3. SEE STANDARD DRAWINGS G-15 AND G-16 FOR WIDTH AND LOCATION REQUIREMENTS.
4. SEE STANDARD DRAWINGS G-2 AND G-10 FOR CURB AND JOINT DETAILS.
5. PLACE EXPANSION JOINT AT RIGHT-OF-WAY.
6. DIMENSIONS SHOWN REFLECT A 6" CURB HEIGHT.
7. RAMP LENGTH CALCULATIONS ARE BASED ON X=1" TO ACCOUNT FOR THE 1" DRIVEWAY LIP.
8. IF USING FOR ALLEY CROSSING, INSTALL TRUNCATED DOMES PER G-30 AT BOTTOM OF RAMPS.

| Revision | By | Approved | Date |
|----------|----|------------|-------|
| Reviewed | | T. STANTON | 04/06 |
| Updated | MR | MR/CV | 02/12 |
| Updated | CV | CV | 12/15 |
| Updated | RP | S. Engeda | 03/22 |

SAN DIEGO REGIONAL STANDARD DRAWING

**CONCRETE DRIVEWAY
(FOR CONFINED RIGHT-OF-WAY)**

RECOMMENDED BY THE SAN DIEGO REGIONAL STANDARDS COMMITTEE

Samantha Engeda 03/24/2022
Chairperson R.C.E. 52241 Date

DRAWING NUMBER **G-14D**

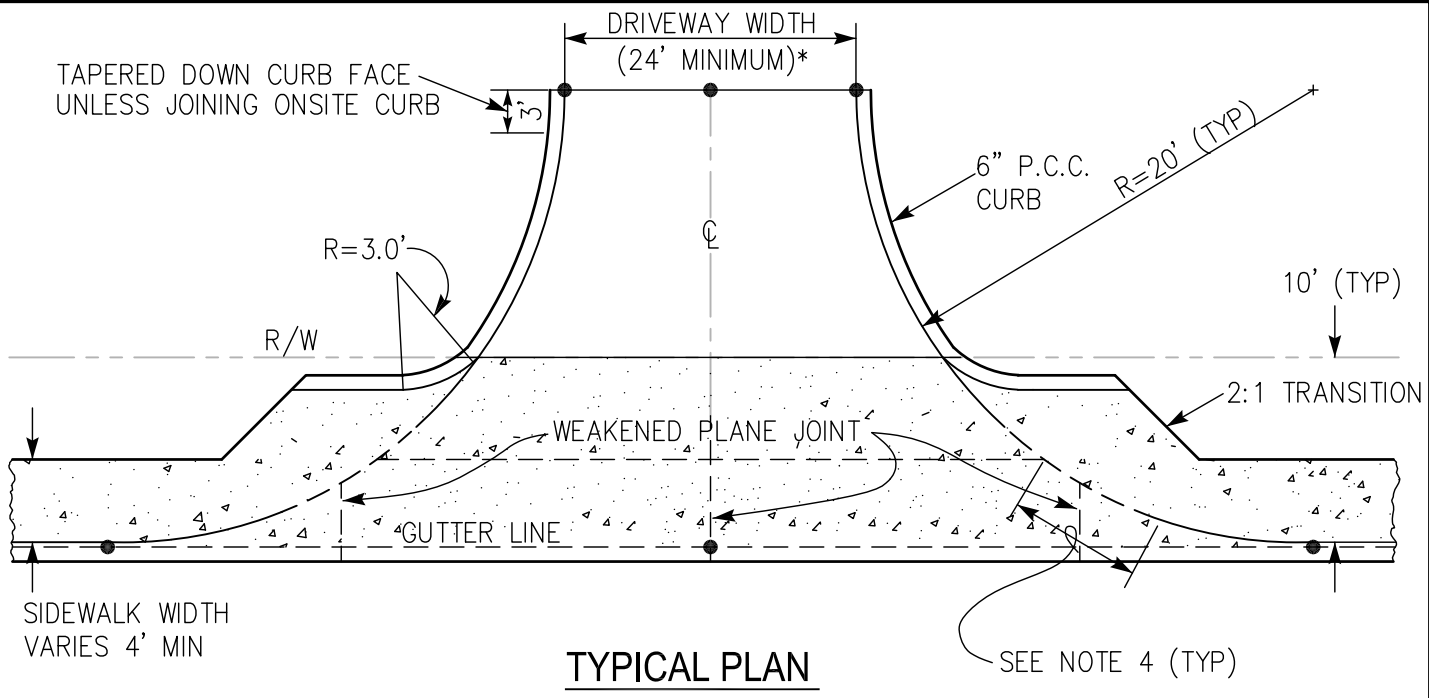

TYPICAL PLAN

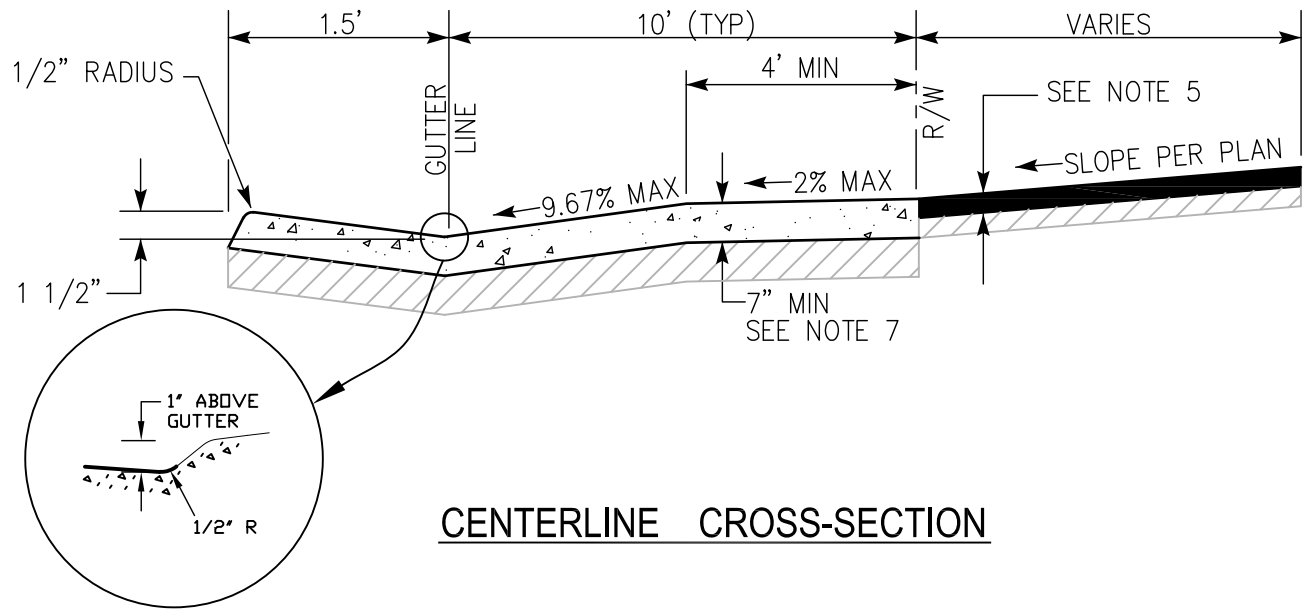

CENTERLINE CROSS-SECTION

1. * OR AS REQUIRED BY THE AGENCY.
2. ● = ELEVATION SHOWN ON PLANS (TOP OF CURB, AND GUTTER ELEVATION)
3. ALL CONCRETE SHALL BE 560-C-3250
4. TRANSITION FROM FULL HEIGHT CURB TO NO CURB. 6FT TRANSITION FOR 5FT WIDE SIDEWALK AND 8FT TRANSITION FOR 6FT WIDE SIDEWALK.
5. PAVEMENT STRUCTURAL SECTION SHALL BE SHOWN ON PLANS.
6. SEE G-2 AND G-10 FOR CURB AND JOINT DETAILS.
7. BASE MATERIAL AS SHOWN ON PLANS.

| | | | | | |
|----------|----|-----------|-------|-------------------------------------|---|
| Revision | By | Approved | Date | SAN DIEGO REGIONAL STANDARD DRAWING | RECOMMENDED BY THE SAN DIEGO REGIONAL STANDARDS COMMITTEE |
| NEW | MR | MR/CV | 09/11 | | CONCRETE DRIVEWAY (ALLEY TYPE) |
| UPDATED | CV | CV | 12/15 | Chairperson R.C.E. 52241 Date | |
| Reviewed | RP | S. Engeda | 03/22 | DRAWING NUMBER G-14E | |
| | | | | | |

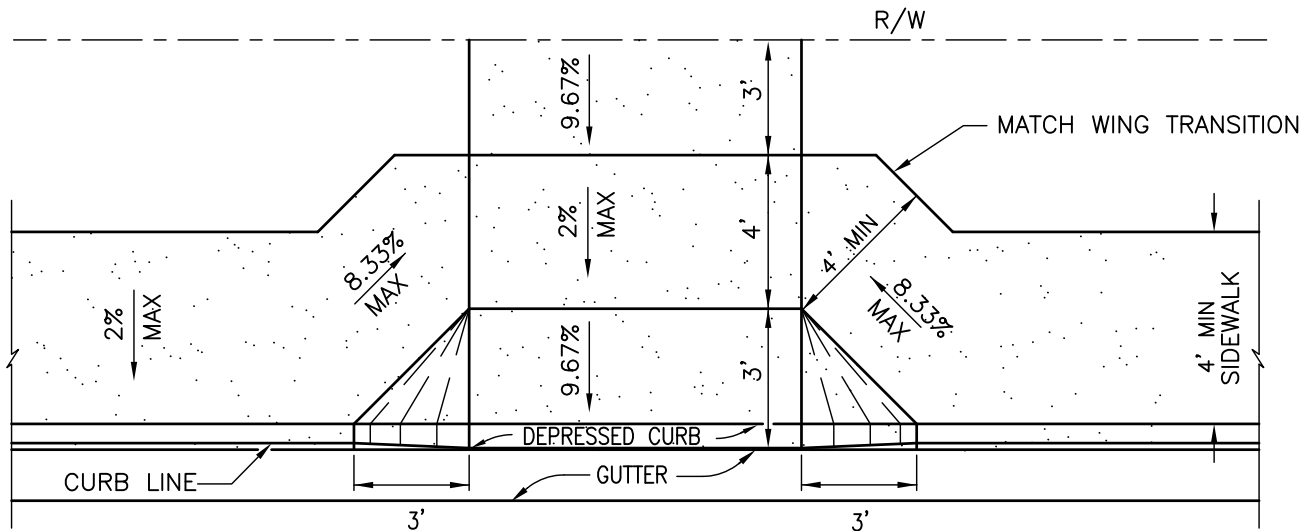

PLAN

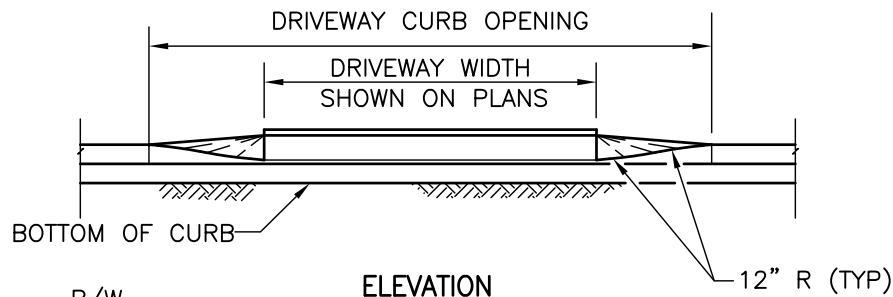

ELEVATION

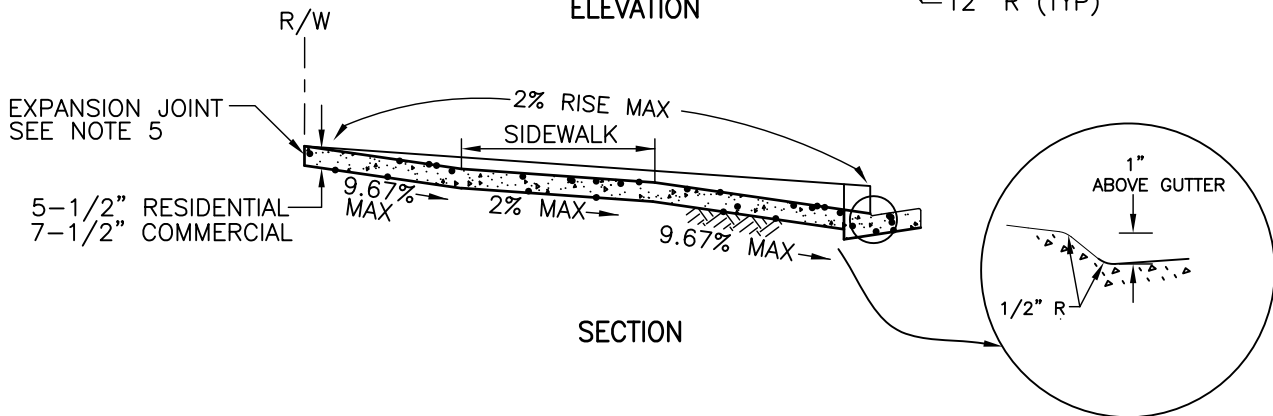

SECTION

NOTES:

1. NO CONCRETE SHALL BE PLACED UNTIL FORMS AND SUBGRADE ARE INSPECTED BY AGENCY.
2. FOR RESIDENTIAL USE, CONCRETE SHALL BE 520-C-2500; FOR COMMERCIAL USE, CONCRETE SHALL BE 560-C-3250.
3. SEE STANDARD DRAWINGS G-15 AND G-16 FOR WIDTH AND LOCATION REQUIREMENTS.
4. DRIVEWAY RAMP TO EXTEND TO 10' FROM CURB FACE OR TO RIGHT-OF-WAY, WHICHEVER IS LESS.
5. PLACE EXPANSION JOINT AT RIGHT-OF-WAY OR 10', WHICHEVER IS LESS.
6. SEE STANDARD DRAWINGS G-2 AND G-10 FOR CURB AND JOINT DETAILS.
7. DIMENSIONS SHOWN REFLECT A 6" CURB HEIGHT.

| Revision | By | Approved | Date |
|----------|----|-----------|-------|
| NEW | MR | MR/CV | 02/12 |
| UPDATED | CV | CV | 12/15 |
| Reviewed | RP | S. Engeda | 03/22 |
| | | | |
| | | | |

SAN DIEGO REGIONAL STANDARD DRAWING

**CONCRETE DRIVEWAY - TYPE B
(CONTIGUOUS SIDEWALK)**

RECOMMENDED BY THE SAN DIEGO REGIONAL STANDARDS COMMITTEE

Somayr Engeda 03/24/2022
Chairperson R.C.E. 52241 Date

DRAWING NUMBER **G-14F**

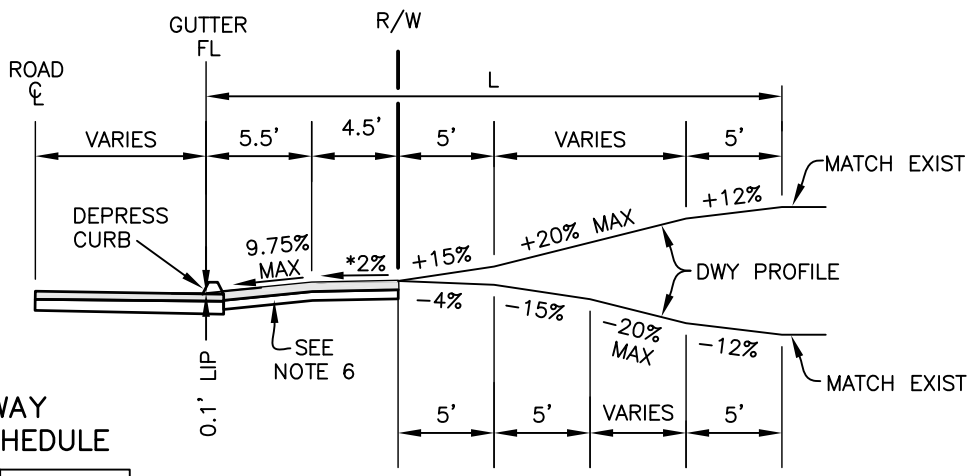
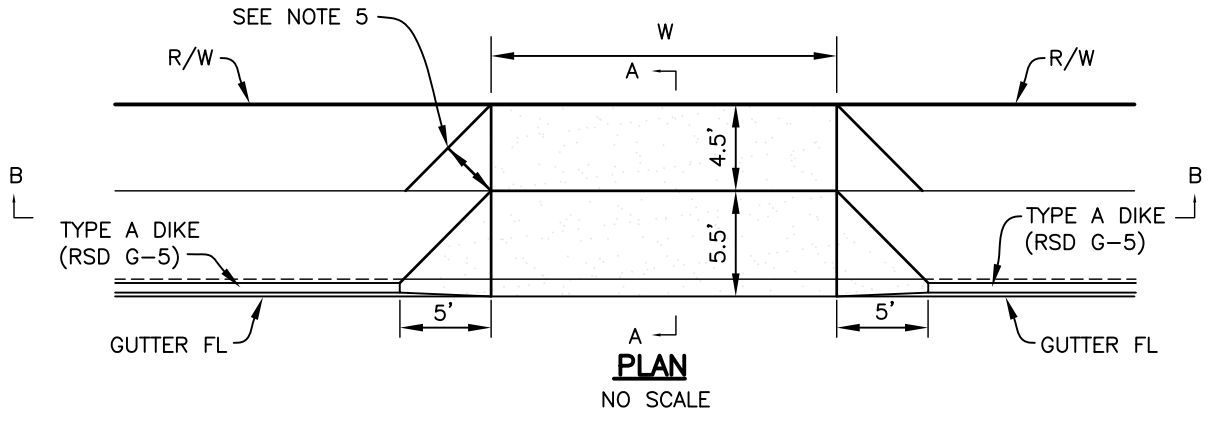

DRIVEWAY PAVING SCHEDULE

| MINIMUM DEPTH OF A.C. | GRADE |
|-----------------------|--------|
| 2" | 0-15% |
| 3" | 16-20% |

MIN DEPTHS PER COUNTY FIRE STDS. LOCAL AGENCY REQUIREMENTS MAY VARY.

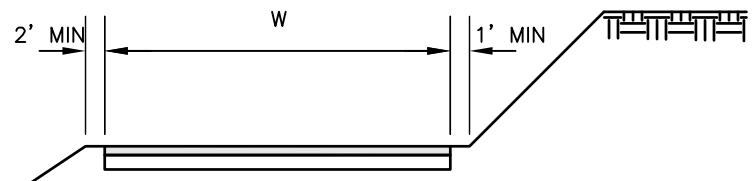

NOTES:

1. DRIVEWAY PROFILE, WIDTH (W) AND LENGTH (L) SHALL BE SHOWN ON PLANS.
2. DRIVEWAYS WITH GRADES GREATER THAN 15% SHALL BE SURFACED WITH ASPHALT CONCRETE (AC) OR PORTLAND CEMENT CONCRETE (PCC).
3. MAXIMUM GRADE BREAK 14% (5' MINIMUM VERTICAL CURVE PREFERRED).
4. SEE SAN DIEGO AREA REGIONAL STANDARD DRAWINGS G-15 & G-16 FOR DRIVEWAY LOCATION & WIDTH REQUIREMENTS AND G-14 SERIES FOR PCC DRIVEWAYS.
5. 4' MINIMUM ADA ACCESS WHEN WALKWAYS ARE PROVIDED.
6. 4" MINIMUM AC OVER 6" MINIMUM BASE, UNLESS OTHERWISE INDICATED ON PLANS.

| | | | | | |
|----------|----|-----------|-------|-------------------------------------|---|
| Revision | By | Approved | Date | SAN DIEGO REGIONAL STANDARD DRAWING | RECOMMENDED BY THE SAN DIEGO REGIONAL STANDARDS COMMITTEE |
| NEW | MR | MR/CV | 09/11 | | <p style="text-align: center;">ASPHALT CONCRETE DRIVEWAY</p> |
| UPDATED | CV | CV | 12/15 | DRAWING NUMBER G-14G | |
| Reviewed | RP | S. Engeda | 03/22 | | |

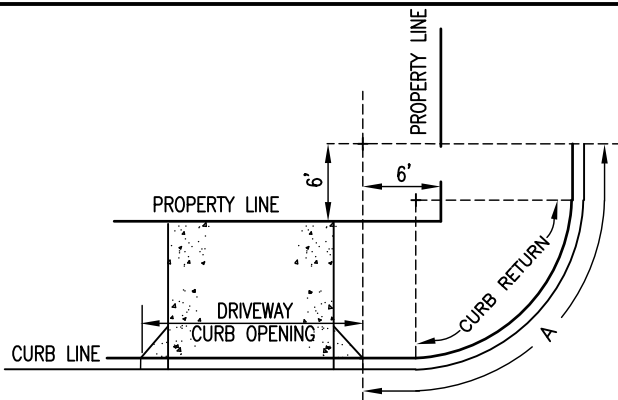

REQUIREMENT 1
 NO PORTION OF ANY CURB OPENING SHALL BE PERMITTED WITHIN 6' OF THE INTERSECTION OF THE PROLONGED PROPERTY LINES AND THE CURB SHOWN BY ARC A.

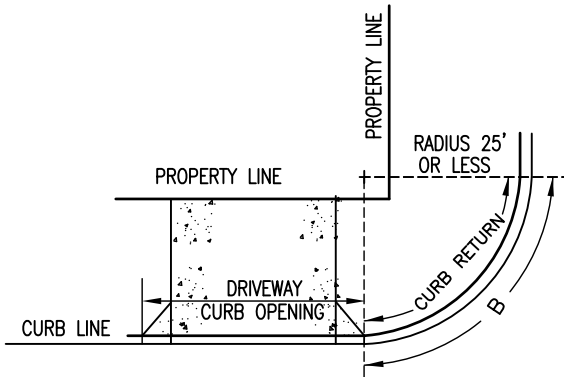

REQUIREMENT 2
 NO PORTION OF ANY CURB OPENING SHALL BE PERMITTED IN THE CURB RETURN WHERE THE RADIUS OF CURB IS 25' OR LESS, AS SHOWN BY ARC B.

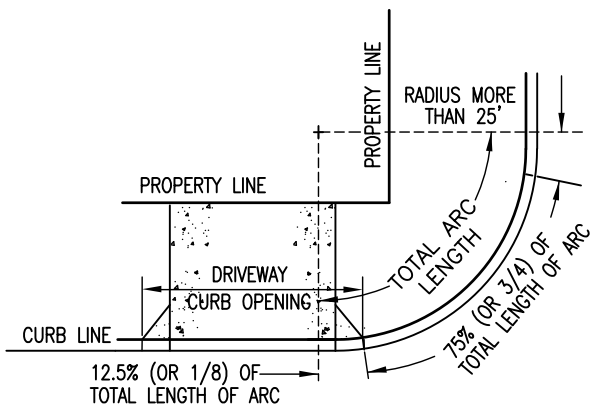

REQUIREMENT 3
 ON ALL CURB RETURNS WHERE THE RADIUS IS MORE THAN 25', CURB OPENINGS MAY ENCRUCH UPON EACH END OF THE RETURN A DISTANCE EQUAL TO 12.5% (OR 1/8) OF THE TOTAL LENGTH OF THE ARC ON THE CURB RETURN, THUS LEAVING AT LEAST 75% (OR 3/4) OF THE LENGTH OF ARC ON THE RETURN FACE FREE FROM DRIVEWAY ENCRUCHMENT, PROVIDED REQUIREMENT 1 IS MET.

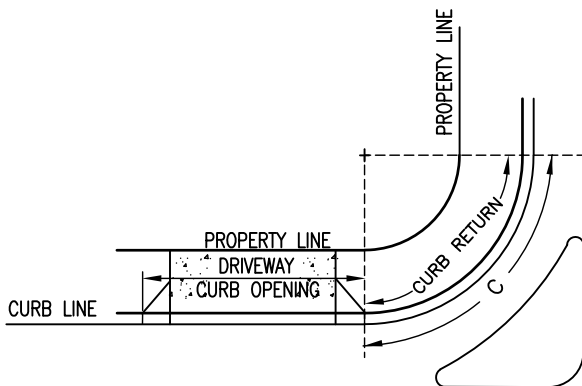

REQUIREMENT 4
 NO PORTION OF ANY CURB OPENING SHALL BE PERMITTED IN THE CURB RETURN WHERE A SEPARATE TURNING MOVEMENT IS PROVIDED, AS SHOWN BY ARC C.

| Revision | By | Approved | Date |
|----------|----|-------------|-------|
| ORIGINAL | | KERCHEVAL | 12/75 |
| UPDATED | CV | CV | 12/15 |
| Reviewed | MW | M. Widelski | 10/18 |
| Reviewed | RP | S. Engeda | 03/22 |

SAN DIEGO REGIONAL STANDARD DRAWING

DRIVEWAY LOCATION - ADJACENT TO CURB RETURNS AND STREET LINES

RECOMMENDED BY THE SAN DIEGO REGIONAL STANDARDS COMMITTEE

Saman Engeda 03/24/2022
 Chairperson R.C.E. 52241 Date

DRAWING NUMBER **G-15**

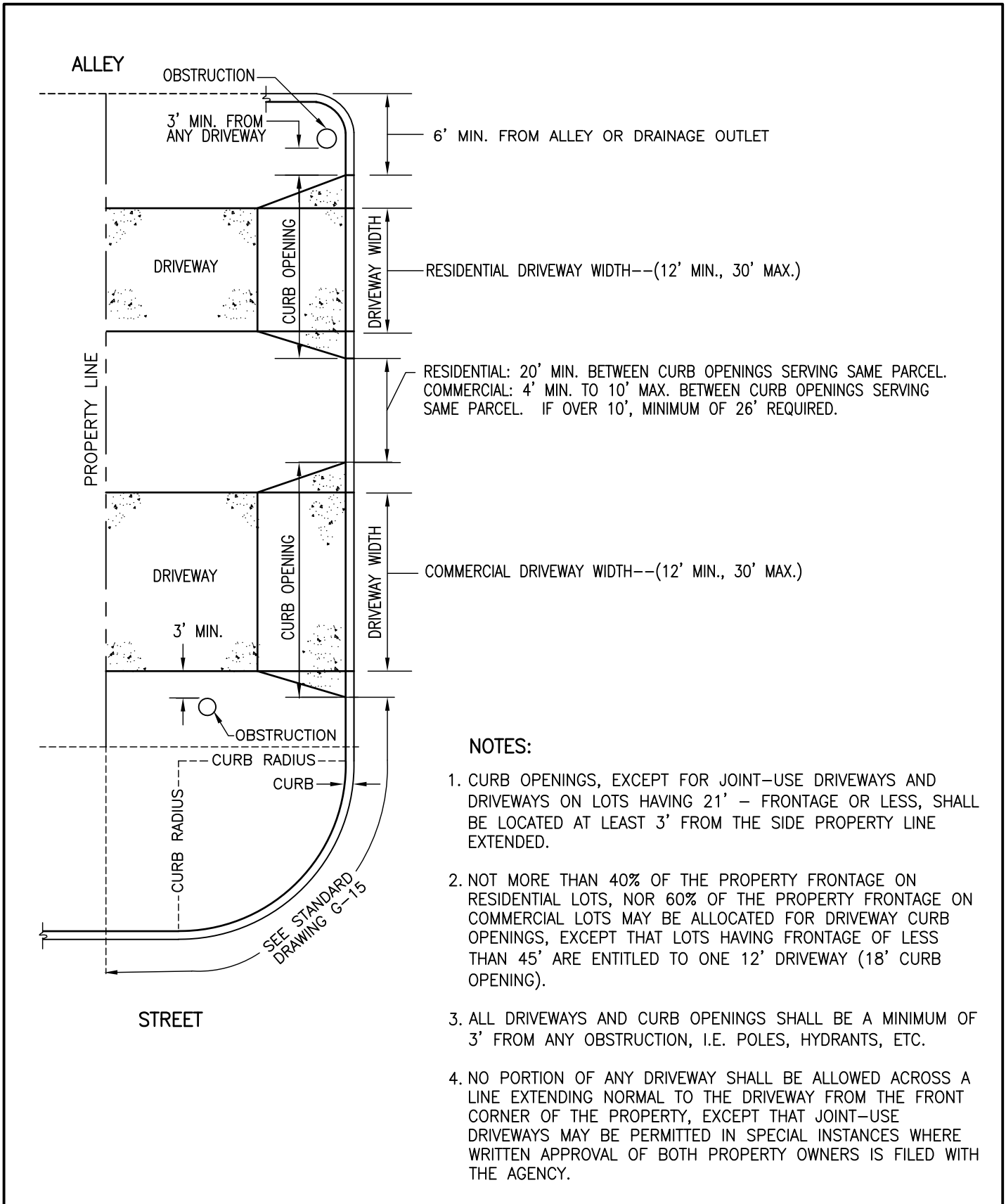

NOTES:

1. CURB OPENINGS, EXCEPT FOR JOINT-USE DRIVEWAYS AND DRIVEWAYS ON LOTS HAVING 21' – FRONTAGE OR LESS, SHALL BE LOCATED AT LEAST 3' FROM THE SIDE PROPERTY LINE EXTENDED.
2. NOT MORE THAN 40% OF THE PROPERTY FRONTAGE ON RESIDENTIAL LOTS, NOR 60% OF THE PROPERTY FRONTAGE ON COMMERCIAL LOTS MAY BE ALLOCATED FOR DRIVEWAY CURB OPENINGS, EXCEPT THAT LOTS HAVING FRONTAGE OF LESS THAN 45' ARE ENTITLED TO ONE 12' DRIVEWAY (18' CURB OPENING).
3. ALL DRIVEWAYS AND CURB OPENINGS SHALL BE A MINIMUM OF 3' FROM ANY OBSTRUCTION, I.E. POLES, HYDRANTS, ETC.
4. NO PORTION OF ANY DRIVEWAY SHALL BE ALLOWED ACROSS A LINE EXTENDING NORMAL TO THE DRIVEWAY FROM THE FRONT CORNER OF THE PROPERTY, EXCEPT THAT JOINT-USE DRIVEWAYS MAY BE PERMITTED IN SPECIAL INSTANCES WHERE WRITTEN APPROVAL OF BOTH PROPERTY OWNERS IS FILED WITH THE AGENCY.

| Revision | By | Approved | Date |
|----------|----|-----------|-------|
| ORIGINAL | | KERCHEVAL | 12/75 |
| UPDATED | MR | MR/CV | 03/12 |
| UPDATED | CV | CV | 12/15 |
| Reviewed | RP | S. Engeda | 03/22 |

SAN DIEGO REGIONAL STANDARD DRAWING

**DRIVEWAY LOCATION
AND WIDTH REQUIREMENTS**

RECOMMENDED BY THE SAN DIEGO REGIONAL STANDARDS COMMITTEE

Samantha Engeda 03/24/2022
Chairperson R.C.E. 52241 Date

DRAWING NUMBER G-16

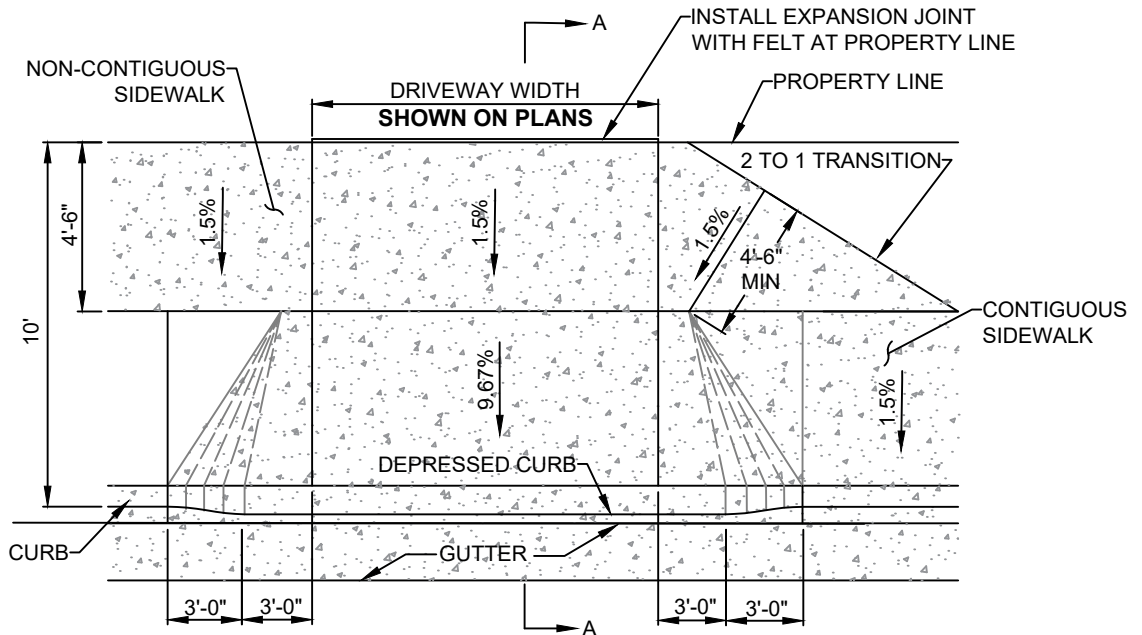

PLAN

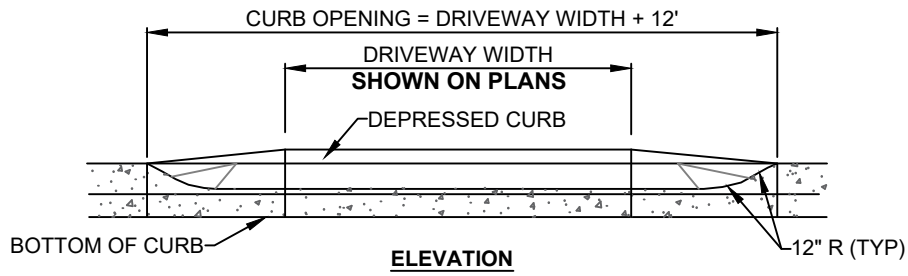

ELEVATION

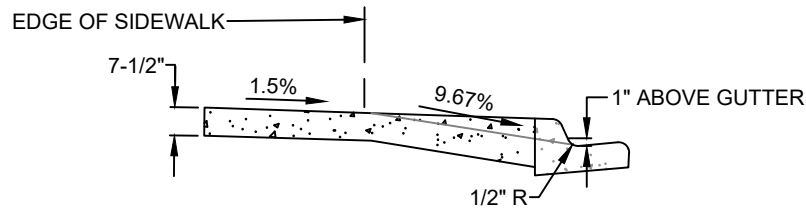

SECTION A-A

NOTES:

1. CONCRETE SHALL NOT BE PLACED UNTIL FORMS AND SUBGRADE ARE INSPECTED AND APPROVED BY THE CITY.
2. CONCRETE SHALL BE 560-C-3250.
3. SEE REGIONAL STANDARD DRAWINGS G-02 AND G-09 FOR CURB AND JOINT DETAILS.
4. METER BOXES SHALL NOT BE LOCATED WITHIN DRIVEWAY.
5. SEE WATER AGENCY STANDARDS (WAS) DRAWING WS-03.
6. DRIVEWAY SHALL BE A CONTINUOUS POUR FROM BACK OF CURB TO PROPERTY LINE.
7. DRIVEWAY WIDTH SHALL BE 30' MINIMUM UNLESS OTHERWISE APPROVED BY THE CITY.
8. PLACE #4 REINFORCING STEEL SPACED 16" O.C. BOTH WAYS.
9. EXPANSION JOINT MATERIAL SHALL BE IN ACCORDANCE TO CITY APPROVED MATERIAL LIST.

LEGEND ON PLANS

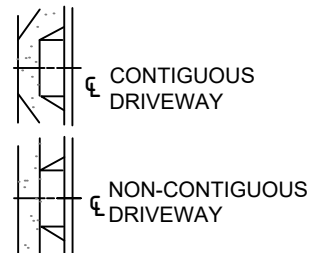

| REVISION | APPROVED | DATE |
|----------|-----------|------------|
| ORIGINAL | C.SCHMITZ | 12/21/2022 |
| | | |
| | | |
| | | |
| | | |

CITY OF SANTEE STANDARD DRAWING

COMMERCIAL CONCRETE DRIVEWAY

APPROVED:

[Signature]
 PRINCIPAL CIVIL ENGINEER
 R.C.E. 60112 DATE: 6/30/2024

DRAWING NUMBER **PW - 38**