

# CITY OF SANTEE

**PRIORITY DEVELOPMENT PROJECT (PDP)  
STORM WATER QUALITY MANAGEMENT PLAN (SWQMP)  
FOR  
St John the Baptizer Ukrainian Catholic Church**

[INSERT PERMIT APPLICATION NUMBERS]

Northwest corner of Carlton Oaks Dr. and Pike Rd intersection  
City of Santee, CA 92071

**ASSESSOR'S PARCEL NUMBER(S):**

**380-112-08-00**

**ENGINEER OF WORK: Jose Raul Gomez P.E.**

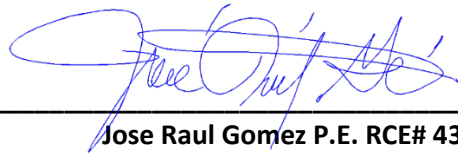

Jose Raul Gomez P.E. RCE# 43306

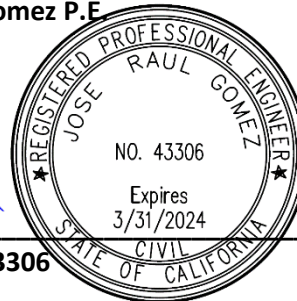

PREPARED FOR:

Catherine George  
Address: PO Box 3116  
La Mesa, CA 91941  
(818) 523-4499

PDP SWQMP PREPARED BY:

Jose Raul Gomez, P.E.  
3071 Buena Vista Ave.  
Lemon Grove, CA 91945  
(619)210-3371

DATE OF SWQMP:  
April 17, 2023

PLANS PREPARED BY:  
Jose Raul Gomez, P.E.  
3071 Buena Vista Ave.  
Lemon Grove, CA 91945  
(619)210-3371

Page intentionally blank

## **TABLE OF CONTENTS**

Acronym Sheet

PDP SWQMP Preparer's Certification Page

PDP SWQMP Project Owner's Certification Page

Submittal Record

Project Vicinity Map

FORM I-1 Applicability of Permanent, Post-Construction Storm Water BMP Requirements

FORM I-2 Project Type Determination Checklist (Standard Project or PDP)

FORM I-3B Site Information Checklist for PDPs

FORM I-4 Source Control BMP Checklist for All Development Projects

FORM I-5 Site Design BMP Checklist for All Development Projects

FORM I-6 Summary of PDP Structural BMPs

Attachment 1: Backup for PDP Pollutant Control BMPs

Attachment 1a: DMA Exhibit

Attachment 1b: Tabular Summary of DMAs and Design Capture Volume Calculations

Attachment 1c: Harvest and Use Feasibility Screening (when applicable)

Attachment 1d: Categorization of Infiltration Feasibility Condition (when applicable)

Attachment 1e: Pollutant Control BMP Design Worksheets / Calculations

Attachment 2: Backup for PDP Hydromodification Control Measures

Attachment 2a: Hydromodification Management Exhibit

Attachment 2b: Management of Critical Coarse Sediment Yield Areas

Attachment 2c: Geomorphic Assessment of Receiving Channels

Attachment 2d: Flow Control Facility Design

Attachment 3: Structural BMP Maintenance Plan

Attachment 3a: B Structural BMP Maintenance Thresholds and Actions

Attachment 3b: Draft Maintenance Agreement (when applicable)

Attachment 4: Copy of Plan Sheets Showing Permanent Storm Water BMPs

## ACRONYMS

APN	Assessor's Parcel Number
BMP	Best Management Practice
HMP	Hydromodification Management Plan
HSG	Hydrologic Soil Group
MS4	Municipal Separate Storm Sewer System
N/A	Not Applicable
NRCS	Natural Resources Conservation Service
PDP	Priority Development Project
PE	Professional Engineer
SC	Source Control
SD	Site Design
SDRWQCB	San Diego Regional Water Quality Control Board
SIC	Standard Industrial Classification
SWQMP	Storm Water Quality Management Plan



# SWQMP PREPARER'S CERTIFICATION PAGE

**Project Name: St John the Baptizer Ukrainian Catholic Church**

**Permit Application Number:**

## PREPARER'S CERTIFICATION

I hereby declare that I am the Engineer in Responsible Charge of design of storm water best management practices (BMPs) for this project, and that I have exercised responsible charge over the design of the BMPs as defined in Section 6703 of the Business and Professions Code, and that the design is consistent with the PDP requirements of the City of Santee BMP Design Manual, which is a design manual for compliance with local [INSERT AGENCY NAME] and regional MS4 Permit (California Regional Water Quality Control Board San Diego Region Order No. R9-2015-0100) requirements for storm water management.

I have read and understand that the [City Engineer] has adopted minimum requirements for managing urban runoff, including storm water, from land development activities, as described in the BMP Design Manual. I certify that this PDP SWQMP has been completed to the best of my ability and accurately reflects the project being proposed and the applicable BMPs proposed to minimize the potentially negative impacts of this project's land development activities on water quality. I understand and acknowledge that the plan check review of this PDP SWQMP by the [City Engineer] is confined to a review and does not relieve me, as the Engineer in Responsible Charge of design of storm water BMPs for this project, of my responsibilities for project design.

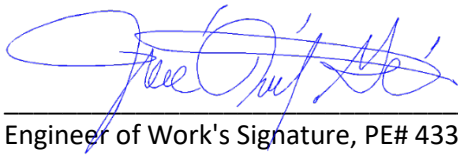

Engineer of Work's Signature, PE# 43306, Ex. Date: 3-31-2024

Jose Raul Gomez

Print Name

Jose Raul Gomez P.E.

Company

04-17-2023

Date

Engineer's Seal:



Page intentionally blank

# SWQMP PROJECT OWNER'S CERTIFICATION PAGE

**Project Name: St John the Baptizer Ukrainian Catholic Church**

**Permit Application Number:**

## PROJECT OWNER'S CERTIFICATION

This PDP SWQMP has been prepared for owner's representative, Catherine George by Jose Raul Gomez P.E. The PDP SWQMP is intended to comply with the PDP requirements of the City of Santee BMP Design Manual, which is a design manual for compliance with local **[INSERT AGENCY NAME]** and regional MS4 Permit (California Regional Water Quality Control Board San Diego Region Order No. R9-2015-0100) requirements for storm water management.

The undersigned, while it owns the subject property, is responsible for the implementation of the provisions of this plan. Once the undersigned transfers its interests in the property, its successor-in-interest shall bear the aforementioned responsibility to implement the best management practices (BMPs) described within this plan, including ensuring on-going operation and maintenance of structural BMPs. A signed copy of this document shall be available on the subject property into perpetuity.

---

Project Owner's Signature

Catherine George, Owner's representative  
Print Name

---

Company

04-17-2023  
Date

Page intentionally blank

## SUBMITTAL RECORD

Use this Table to keep a record of submittals of this PDP SWQMP. Each time the PDP SWQMP is re-submitted, provide the date and status of the project. In column 4 summarize the changes that have been made or indicate if response to plancheck comments is included. When applicable, insert response to plancheck comments behind this page.

Submittal Number	Date	Project Status	Summary of Changes
1	September 15, 2022	<input type="checkbox"/> Preliminary Design / Planning/ CEQA <input checked="" type="checkbox"/> Final Design	Initial Submittal
2	April 17, 2023	<input type="checkbox"/> Preliminary Design / Planning/ CEQA <input checked="" type="checkbox"/> Final Design	Second Submittal
3		<input type="checkbox"/> Preliminary Design / Planning/ CEQA <input type="checkbox"/> Final Design	
4		<input type="checkbox"/> Preliminary Design / Planning/ CEQA <input type="checkbox"/> Final Design	

# PROJECT VICINITY MAP

Project Name: St John the Baptizer Ukrainian Catholic Church  
Permit Application Number:

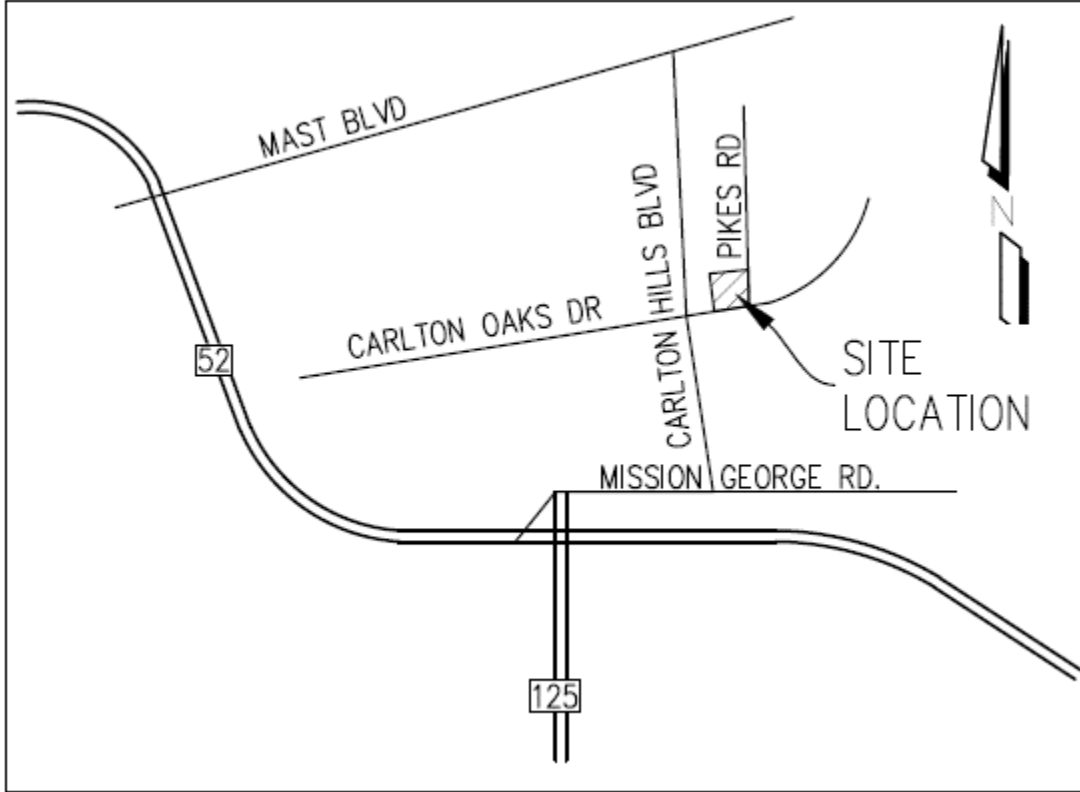

<b>Applicability of Permanent, Post-Construction Storm Water BMP Requirements</b> (Storm Water Intake Form for all Development Permit Applications)		<b>Form I-1</b> Model BMP Design Manual [August 31, 2015]
<b>Project Identification</b>		
Project Name: St John the Baptizer Ukrainian Catholic Church		
Permit Application Number:		Date:
Project Address: Northwest corner of Carlton Oaks Dr. and Pike Rd intersection, Santee, CA 92071		
<b>Determination of Requirements</b>		
<p>The purpose of this form is to identify permanent, post-construction requirements that apply to the project. This form serves as a short <u>summary</u> of applicable requirements, in some cases referencing separate forms that will serve as the backup for the determination of requirements.</p> <p>Answer each step below, starting with Step 1 and progressing through each step until reaching "Stop". <b>Upon reaching a Stop, do not complete further Steps beyond the Stop.</b></p> <p>Refer to BMP Design Manual sections and/or separate forms referenced in each step below.</p>		
Step	Answer	Progression
<b>Step 1:</b> Is the project a "development project"? See Section 1.3 of the BMP Design Manual for guidance.	<input checked="" type="checkbox"/> Yes	Go to Step 2.
	<input type="checkbox"/> No	Stop. Permanent BMP requirements do not apply. No SWQMP will be required. Provide discussion below.
Discussion / justification if the project is <u>not</u> a "development project" (e.g., the project includes <i>only</i> interior remodels within an existing building):		
<b>Step 2:</b> Is the project a Standard Project, Priority Development Project (PDP), or exception to PDP definitions? To answer this item, see Section 1.4 of the BMP Design Manual <i>in its entirety</i> for guidance, AND complete Form I-2, Project Type Determination.	<input type="checkbox"/> Standard Project	Stop. <u>Only</u> Standard Project requirements apply, including <u>Standard Project SWQMP</u> .
	<input checked="" type="checkbox"/> PDP	<u>Standard and PDP</u> requirements apply, including <u>PDP SWQMP</u> . Go to Step 3.
	<input type="checkbox"/> Exception to PDP definitions	Stop. <u>Standard Project</u> requirements apply, <u>and any additional requirements specific to the type of project</u> . Provide discussion and list any additional requirements below. Prepare <u>Standard Project SWQMP</u> .

[Step 2 Continued from Page 1] Discussion / justification, and additional requirements for exceptions to PDP definitions, if applicable:

<b>Step 3 (PDPs only).</b> Is the project subject to earlier PDP requirements due to a prior lawful approval? See Section 1.10 of the BMP Design Manual for guidance.	<input type="checkbox"/> Yes	Consult the [City Engineer] to determine requirements. Provide discussion and identify requirements below. Go to Step 4.
	<input checked="" type="checkbox"/> No	BMP Design Manual PDP requirements apply. Go to Step 4.

Discussion / justification of prior lawful approval, and identify requirements (*not required if prior lawful approval does not apply*):

<b>Step 4 (PDPs only).</b> Do hydromodification control requirements apply? See Section 1.6 of the BMP Design Manual for guidance.	<input type="checkbox"/> Yes	PDP structural BMPs required for pollutant control (Chapter 5) and hydromodification control (Chapter 6). Go to Step 5.
	<input checked="" type="checkbox"/> No	Stop. PDP structural BMPs required for pollutant control (Chapter 5) only. Provide brief discussion of exemption to hydromodification control below.

Discussion / justification if hydromodification control requirements do not apply:  
The proposed grading will discharge into an existing storm drain (conduit f15e, per city of Santee Citywide drainage study and Hydrology Master Plan) which is exempt of hydromodification control per SANDAG/SanGIS Regional GIS Data Base. Refer to the attached hydromodification Exemption Exhibit.

<b>Step 5 (PDPs subject to hydromodification control requirements only).</b> Does protection of critical coarse sediment yield areas apply based on review of WMAA Potential Critical Coarse Sediment Yield Area Map? See Section 6.2 of the BMP Design Manual for guidance.	<input type="checkbox"/> Yes	Management measures required for protection of critical coarse sediment yield areas (Chapter 6.2). Stop.
	<input type="checkbox"/> No	Management measures not required for protection of critical coarse sediment yield areas. Provide brief discussion below. Stop.



<b>Priority Determination Form</b>		<b>Form I-2</b> Model BMP Design Manual [August 31, 2015]	
<b>Project Information</b>			
Project Name: St John the Baptizer Ukrainian Catholic Church			
Permit Application Number:		Date:	
Project Address: Northwest corner of Carlton Oaks Dr. and Pike Rd intersection, Santee, CA 92071			
<b>Project Type Determination: Standard Project or Priority Development Project (PDP)</b>			
The project is (select one): <input checked="" type="checkbox"/> New Development <input type="checkbox"/> Redevelopment			
The total proposed newly created or replaced impervious area is: <u>15,153</u> ft <sup>2</sup> ( <u>0.348</u> ) acres			
Is the project in any of the following categories, (a) through (f)?			
Yes <input checked="" type="checkbox"/>	No <input type="checkbox"/>	(a)	New development projects that create 10,000 square feet or more of impervious surfaces (collectively over the entire project site). This includes commercial, industrial, residential, mixed-use, and public development projects on public or private land.
Yes <input type="checkbox"/>	No <input checked="" type="checkbox"/>	(b)	Redevelopment projects that create and/or replace 5,000 square feet or more of impervious surface (collectively over the entire project site on an existing site of 10,000 square feet or more of impervious surfaces). This includes commercial, industrial, residential, mixed-use, and public development projects on public or private land.
Yes <input checked="" type="checkbox"/>	No <input type="checkbox"/>	(c)	<p>New and redevelopment projects that create and/or replace 5,000 square feet or more of impervious surface (collectively over the entire project site), and support one or more of the following uses:</p> <ul style="list-style-type: none"> <li>(i) Restaurants. This category is defined as a facility that sells prepared foods and drinks for consumption, including stationary lunch counters and refreshment stands selling prepared foods and drinks for immediate consumption (Standard Industrial Classification (SIC) code 5812).</li> <li>(ii) Hillside development projects. This category includes development on any natural slope that is twenty-five percent or greater.</li> <li>(iii) Parking lots. This category is defined as a land area or facility for the temporary parking or storage of motor vehicles used personally, for business, or for commerce.</li> <li>(iv) Streets, roads, highways, freeways, and driveways. This category is defined as any paved impervious surface used for the transportation of automobiles, trucks, motorcycles, and other vehicles.</li> </ul>

Form I-2 Page 2, Form Template Date: August 31, 2015

Yes <input type="checkbox"/>	No <input checked="" type="checkbox"/>	(d)	<p>New or redevelopment projects that create and/or replace 2,500 square feet or more of impervious surface (collectively over the entire project site), and discharging directly to an Environmentally Sensitive Area (ESA). "Discharging directly to" includes flow that is conveyed overland a distance of 200 feet or less from the project to the ESA, or conveyed in a pipe or open channel any distance as an isolated flow from the project to the ESA (i.e. not commingled with flows from adjacent lands).</p> <p><i>Note: ESAs are areas that include but are not limited to all Clean Water Act Section 303(d) impaired water bodies; areas designated as Areas of Special Biological Significance by the State Water Board and San Diego Water Board; State Water Quality Protected Areas; water bodies designated with the RARE beneficial use by the State Water Board and San Diego Water Board; and any other equivalent environmentally sensitive areas which have been identified by the Copermitttees. See BMP Design Manual Section 1.4.2 for additional guidance.</i></p>
Yes <input type="checkbox"/>	No <input checked="" type="checkbox"/>	(e)	<p>New development projects, or redevelopment projects that create and/or replace 5,000 square feet or more of impervious surface, that support one or more of the following uses:</p> <p>(i) Automotive repair shops. This category is defined as a facility that is categorized in any one of the following SIC codes: 5013, 5014, 5541, 7532-7534, or 7536-7539.</p> <p>(ii) Retail gasoline outlets (RGOs). This category includes RGOs that meet the following criteria: (a) 5,000 square feet or more or (b) a projected Average Daily Traffic (ADT) of 100 or more vehicles per day.</p>
Yes <input type="checkbox"/>	No <input checked="" type="checkbox"/>	(f)	<p>New or redevelopment projects that result in the disturbance of one or more acres of land and are expected to generate pollutants post construction.</p> <p><i>Note: See BMP Design Manual Section 1.4.2 for additional guidance.</i></p>

Does the project meet the definition of one or more of the Priority Development Project categories (a) through (f) listed above?

- No – the project is not a Priority Development Project (Standard Project).
- Yes – the project is a Priority Development Project (PDP).

The following is for redevelopment PDPs only:

The area of existing (pre-project) impervious area at the project site is: 0 ft<sup>2</sup> (A)

The total proposed newly created or replaced impervious area is 15,153 ft<sup>2</sup> (B)

Percent impervious surface created or replaced (B/A)\*100: -%

The percent impervious surface created or replaced is (select one based on the above calculation):

- less than or equal to fifty percent (50%) – only new impervious areas are considered PDP

OR

- greater than fifty percent (50%) – the entire project site is a PDP

<b>Site Design Checklist For PDPs</b>		<b>Form I-3B (PDPs) Model BMP Design Manual [August 31, 2015]</b>
<b>Project Summary Information</b>		
Project Name	St John the Baptizer Ukrainian Catholic Church	
Project Address	Northwest corner of Carlton Oaks Dr. and Pike Rd intersection, Santee, CA 92071	
Assessor's Parcel Number(s) (APN(s))	380-112-08-00	
Permit Application Number		
Project Hydrologic Unit	Select One: <input type="checkbox"/> Santa Margarita 902 <input type="checkbox"/> San Luis Rey 903 <input type="checkbox"/> Carlsbad 904 <input type="checkbox"/> San Dieguito 905 <input type="checkbox"/> Penasquitos 906 <input checked="" type="checkbox"/> San Diego 907 <input type="checkbox"/> Pueblo San Diego 908 <input type="checkbox"/> Sweetwater 909 <input type="checkbox"/> Otay 910 <input type="checkbox"/> Tijuana 911	
Project Watershed (Complete Hydrologic Unit, Area, and Subarea Name with Numeric Identifier)	Hydrologic Unit: San Diego Hydrologic Area: Lower San Diego Hydrologic Sub-Area: Santee, #907.12	
Parcel Area (total area of Assessor's Parcel(s) associated with the project)	<u>0.587</u> Acres ( <u>25,557</u> Square Feet)	
Area to be Disturbed by the Project (Project Area)	<u>0.469</u> Acres ( <u>20,444</u> Square Feet)	
Project Proposed Impervious Area (subset of Project Area)	<u>0.348</u> Acres ( <u>15,153</u> Square Feet)	
Project Proposed Pervious Area (subset of Project Area)	<u>0.121</u> Acres ( <u>5,291</u> Square Feet)	
Note: Proposed Impervious Area + Proposed Pervious Area = Area to be Disturbed by the Project. This may be less than the Parcel Area.		

**Description of Existing Site Condition**

Current Status of the Site (select all that apply):

- Existing development
- Previously graded but not built out
- Demolition completed without new construction
- Agricultural or other non-impervious use
- Vacant, undeveloped/natural

Description / Additional Information:

Vacant land with light vegetation and contains a small seasonal drainage course and headwall inlet at the western property line. The site has 2 to 50% slopes from North to Southwest.

Existing Land Cover Includes (select all that apply):

- Vegetative Cover
- Non-Vegetated Pervious Areas
- Impervious Areas

Description / Additional Information:

The site is a vacant land with light vegetation and barren areas.

Underlying Soil belongs to Hydrologic Soil Group (select all that apply):

- NRCS Type A
- NRCS Type B
- NRCS Type C
- NRCS Type D

Approximate Depth to Groundwater (GW):

- GW Depth < 5 feet
- 5 feet < GW Depth < 10 feet
- 10 feet < GW Depth < 20 feet
- GW Depth > 20 feet

Existing Natural Hydrologic Features (select all that apply):

- Watercourses
- Seeps
- Springs
- Wetlands
- None

Description / Additional Information:

Dry and seasonal creek in the western property line.

**Description of Existing Site Drainage Patterns**

How is storm water runoff conveyed from the site? At a minimum, this description should answer:

- (1) whether existing drainage conveyance is natural or urban;
- (2) Is runoff from offsite conveyed through the site? if yes, quantify all offsite drainage areas, design flows, and locations where offsite flows enter the project site, and summarize how such flows are conveyed through the site;
- (3) Provide details regarding existing project site drainage conveyance network, including any existing storm drains, concrete channels, swales, detention facilities, storm water treatment facilities, natural or constructed channels; and
- (4) Identify all discharge locations from the existing project site along with a summary of conveyance system size and capacity for each of the discharge locations. Provide summary of the pre-project drainage areas and design flows to each of the existing runoff discharge locations.

Describe existing site drainage patterns:

- 1. The existing drainage includes a natural tributary to a dry/seasonal creek which conveys the runoff from offsite, traverses the property along the western area and discharges into an existing City owned storm drain system.
- 2. Yes, a runoff of 49 cfs conveys to a dry/seasonal creek at the western property line. Onsite runoff is equal to 1.85 cfs. which is included in the 49 cfs, per Hydrology Map, City of Santee Hydrology Master Plan, Plate 2, Concentration point F20.
- 3. The existing drainage facilities that affect or traverse this project are open natural channel type and existing storm drain system.
- 4. The discharge location from the existing project is located at the southwest corner of the site and consist in a 36" CMP pipe & Headwall and receive the onsite + offsite runoff equal to 49 cfs.

**Description of Proposed Site Development**

Project Description / Proposed Land Use and/or Activities:

The project will develop a Church that contains a two access driveway, walkways and planter areas throughout the site.

The onsite runoff on walkways, parking lot and driveway will sheet flow and concentrate in a concrete valley ditch located in the parking lot area and discharge into the BMP facility.

List/describe proposed impervious features of the project (e.g., buildings, roadways, parking lots, courtyards, athletic courts, other impervious features):

- Church building
- Onsite concrete walkways
- Two access driveways
- Parking lots

List/describe proposed pervious features of the project (e.g., landscape areas):

- Landscape planters on a side of the walkways
- Treatment area at the southwest part of the site.

Does the project include grading and changes to site topography?

- Yes
- No

Description / Additional Information:

The site will be filled at the western property line.

**Description of Proposed Site Drainage Patterns**

Does the project include changes to site drainage (e.g., installation of new storm water conveyance systems)?

- Yes
- No

If yes, provide details regarding the proposed project site drainage conveyance network, including storm drains, concrete channels, swales, detention facilities, storm water treatment facilities, natural or constructed channels, and the method for conveying offsite flows through or around the proposed project site. Identify all discharge locations from the proposed project site along with a summary of the conveyance system size and capacity for each of the discharge locations. Provide a summary of pre- and post-project drainage areas and design flows to each of the runoff discharge locations. Reference the drainage study for detailed calculations.

Describe proposed site drainage patterns:

The onsite runoff from roofs, walkways, landscaping and driveways will sheet flow through the parking lots and concentrate at the gutter on the western side of the parking lot. These will be collected and discharged into the BMP facility for treatment/flow control.

Overflow discharge capacity from the BMP device is calculated based on Q(100) runoff rates and will be discharged into the dry seasonal creek (Existing riprap) and get into the existing 36" CMP Public storm drain at the southwest corner of the site.

Pre-project drainage area = 0.587 cfs.

Pre-project Q(100) = 1.85 cfs.

Post-project drainage area = 0.587 cfs.

Post-project Unmitigated Q(100) = 2.29 cfs.

Post-project Mitigated Q(100) = 1.67 cfs.

Identify whether any of the following features, activities, and/or pollutant source areas will be present (select all that apply):

- On-site storm drain inlets
- Interior floor drains and elevator shaft sump pumps
- Interior parking garages
- Need for future indoor & structural pest control
- Landscape/Outdoor Pesticide Use
- Pools, spas, ponds, decorative fountains, and other water features
- Food service
- Refuse areas
- Industrial processes
- Outdoor storage of equipment or materials
- Vehicle and Equipment Cleaning
- Vehicle/Equipment Repair and Maintenance
- Fuel Dispensing Areas
- Loading Docks
- Fire Sprinkler Test Water
- Miscellaneous Drain or Wash Water
- Plazas, sidewalks, and parking lots

Description / Additional Information:



**Identification and Narrative of Receiving Water and Pollutants of Concern**

Describe flow path of storm water from the project site discharge location(s), through urban storm conveyance systems as applicable, to receiving creeks, rivers, and lagoons as applicable, and ultimate discharge to the Pacific Ocean (or bay, lagoon, lake or reservoir, as applicable):

The project runoff will discharge into an existing 36" CMP public storm drain located at southwest corner of the site at Carlton Oaks Dr. From this point the storm drain consists of a combination of underground conduits until final discharge to San Diego River at Carlon Hills Blvd.

List any 303(d) impaired water bodies within the path of storm water from the project site to the Pacific Ocean (or bay, lagoon, lake or reservoir, as applicable), identify the pollutant(s)/stressor(s) causing impairment, and identify any TMDLs and/or Highest Priority Pollutants from the WQIP for the impaired water bodies:

<b>303(d) Impaired Water Body</b>	<b>Pollutant(s)/Stressor(s)</b>	<b>TMDLs / WQIP Highest Priority Pollutant</b>
Eucalyptus Creek	Diazinon, Indicator Bacteria	
Forester Creek	Indicator bacteria, Nitrogen, Phosphorus, Selenium	
Los Coches Creek	Indicator bacteria, Nitrogen, Phosphorus, Selenium	
San Diego River (Lower)	Oxygen, Dissolved, Indicator Bacteria, Benthic Community Effects, Cadmium, Nitrogen, Phosphorus, Total dissolved solids, Toxicity	
San Diego River (Upper)	Indicator Bacteria, Oxygen, Dissolved, Sulfates	
San Vicente Reservoir	Chloride, Color, Nitrogen, Sulfates, pH.	
Sycamore Canyon	Oxygen, Dissolved	

**Identification of Project Site Pollutants\***

**\*Identification of project site pollutants is only required if flow-thru treatment BMPs are implemented onsite in lieu of retention or biofiltration BMPs (note the project must also participate in an alternative compliance program unless prior lawful approval to meet earlier PDP requirements is demonstrated)**

Identify pollutants expected from the project site based on all proposed use(s) of the site (see BMP Design Manual Appendix B.6):

<b>Pollutant</b>	<b>Not Applicable to the Project Site</b>	<b>Expected from the Project Site</b>	<b>Also a Receiving Water Pollutant of Concern</b>
Sediment			
Nutrients			
Heavy Metals			

Organic Compounds			
Trash & Debris			
Oxygen Demanding Substances			
Oil & Grease			
Bacteria & Viruses			
Pesticides			

**Hydromodification Management Requirements**

Do hydromodification management requirements apply (see Section 1.6 of the BMP Design Manual)?

- Yes, hydromodification management flow control structural BMPs required.
- No, the project will discharge runoff directly to existing underground storm drains discharging directly to water storage reservoirs, lakes, enclosed embayments, or the Pacific Ocean.
- No, the project will discharge runoff directly to conveyance channels whose bed and bank are concrete-lined all the way from the point of discharge to water storage reservoirs, lakes, enclosed embayments, or the Pacific Ocean.
- No, the project will discharge runoff directly to an area identified as appropriate for an exemption by the WMAA for the watershed in which the project resides.

Description / Additional Information (to be provided if a 'No' answer has been selected above):



The proposed grading will discharge into an existing storm drain (conduit f15e, per city of Santee Citywide drainage study and Hydrology Master Plan) which is exempt of hydromodification control per SANDAG/SanGIS Regional GIS Data Base. Refer to the attached hydromodification Exemption Exhibit.



# Hydromodification Exemption Exhibit

St John the Baptizer Ukrainian Catholic Church

## Legend

-  Hydromod Exemptions
-  San Diego River Floodplain
-  San Diego River Floodway

Project Location

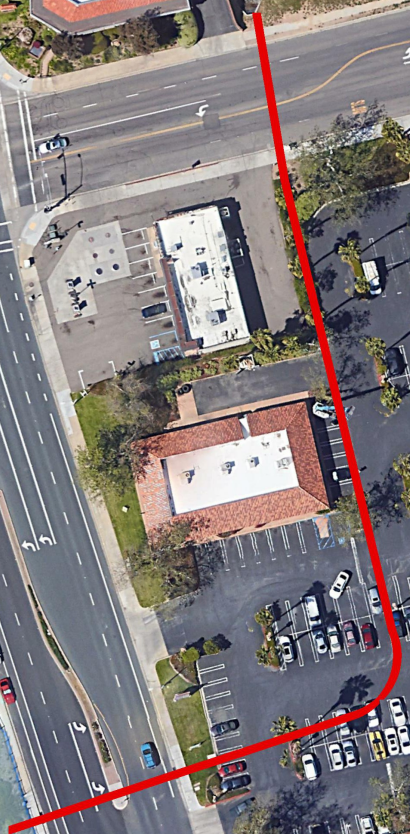

300 ft



**Critical Coarse Sediment Yield Areas\***

**\*This Section only required if hydromodification management requirements apply**

Based on the maps provided within the WMAA, do potential critical coarse sediment yield areas exist within the project drainage boundaries?

- Yes
- No, No critical coarse sediment yield areas to be protected based on WMAA maps

If yes, have any of the optional analyses presented in Section 6.2 of the BMP Design Manual been performed?

- 6.2.1 Verification of Geomorphic Landscape Units (GLUs) Onsite
- 6.2.2 Downstream Systems Sensitivity to Coarse Sediment
- 6.2.3 Optional Additional Analysis of Potential Critical Coarse Sediment Yield Areas Onsite
- No optional analyses performed, the project will avoid critical coarse sediment yield areas identified based on WMAA maps

If optional analyses were performed, what is the final result?

- No critical coarse sediment yield areas to be protected based on verification of GLUs onsite
- Critical coarse sediment yield areas exist but additional analysis has determined that protection is not required. Documentation attached in Attachment 2.b of the SWQMP.
- Critical coarse sediment yield areas exist and require protection. The project will implement management measures described in Sections 6.2.4 and 6.2.5 as applicable, and the areas are identified on the SWQMP Exhibit.

Discussion / Additional Information:

**Flow Control for Post-Project Runoff\***

**\*This Section only required if hydromodification management requirements apply**

List and describe point(s) of compliance (POCs) for flow control for hydromodification management (see Section 6.3.1). For each POC, provide a POC identification name or number correlating to the project's HMP Exhibit and a receiving channel identification name or number correlating to the project's HMP Exhibit.

Non Applicable.

Has a geomorphic assessment been performed for the receiving channel(s)?

- No, the low flow threshold is 0.1Q2 (default low flow threshold)
- Yes, the result is the low flow threshold is 0.1Q2
- Yes, the result is the low flow threshold is 0.3Q2
- Yes, the result is the low flow threshold is 0.5Q2

If a geomorphic assessment has been performed, provide title, date, and preparer:

Discussion / Additional Information: (optional)

Non Applicable.

**Other Site Requirements and Constraints**

When applicable, list other site requirements or constraints that will influence storm water management design, such as zoning requirements including setbacks and open space, or local codes governing minimum street width, sidewalk construction, allowable pavement types, and drainage requirements.

Non Applicable.

**Optional Additional Information or Continuation of Previous Sections As Needed**

This space provided for additional information or continuation of information from previous sections as needed.

Source Control BMP Checklist for All Development Projects (Standard Projects and Priority Development Projects)		Form I-4 Model BMP Design Manual [August 31, 2015]	
<b>Project Identification</b>			
Project Name: St John the Baptizer Ukrainian Catholic Church			
Permit Application Number			
<b>Source Control BMPs</b>			
All development projects must implement source control BMPs SC-1 through SC-6 where applicable and feasible. See Chapter 4 and Appendix E of the Model BMP Design Manual for information to implement source control BMPs shown in this checklist.			
Answer each category below pursuant to the following.			
<ul style="list-style-type: none"> <li>• "Yes" means the project will implement the source control BMP as described in Chapter 4 and/or Appendix E of the Model BMP Design Manual. Discussion / justification is not required.</li> <li>• "No" means the BMP is applicable to the project but it is not feasible to implement. Discussion / justification must be provided.</li> <li>• "N/A" means the BMP is not applicable at the project site because the project does not include the feature that is addressed by the BMP (e.g., the project has no outdoor materials storage areas). Discussion / justification may be provided.</li> </ul>			
<b>Source Control Requirement</b>		<b>Applied?</b>	
<b>SC-1</b> Prevention of Illicit Discharges into the MS4		<input checked="" type="checkbox"/> Yes	<input type="checkbox"/> No <input type="checkbox"/> N/A
Discussion / justification if SC-1 not implemented:			
<b>SC-2</b> Storm Drain Stenciling or Signage		<input checked="" type="checkbox"/> Yes	<input type="checkbox"/> No <input type="checkbox"/> N/A
Discussion / justification if SC-2 not implemented:			
<b>SC-3</b> Protect Outdoor Materials Storage Areas from Rainfall, Run-On, Runoff, and Wind Dispersal		<input checked="" type="checkbox"/> Yes	<input type="checkbox"/> No <input type="checkbox"/> N/A
Discussion / justification if SC-3 not implemented:			
<b>SC-4</b> Protect Materials Stored in Outdoor Work Areas from Rainfall, Run-On, Runoff, and Wind Dispersal		<input checked="" type="checkbox"/> Yes	<input type="checkbox"/> No <input type="checkbox"/> N/A
Discussion / justification if SC-4 not implemented:			



Source Control Requirement	Applied?		
<b>SC-5</b> Protect Trash Storage Areas from Rainfall, Run-On, Runoff, and Wind Dispersal	<input checked="" type="checkbox"/> Yes	<input type="checkbox"/> No	<input type="checkbox"/> N/A
Discussion / justification if SC-5 not implemented:			
<p><b>SC-6</b> Additional BMPs Based on Potential Sources of Runoff Pollutants (must answer for each source listed below)</p> <ul style="list-style-type: none"> <li><input checked="" type="checkbox"/> On-site storm drain inlets</li> <li><input type="checkbox"/> Interior floor drains and elevator shaft sump pumps</li> <li><input type="checkbox"/> Interior parking garages</li> <li><input type="checkbox"/> Need for future indoor &amp; structural pest control</li> <li><input checked="" type="checkbox"/> Landscape/Outdoor Pesticide Use</li> <li><input type="checkbox"/> Pools, spas, ponds, decorative fountains, and other water features</li> <li><input type="checkbox"/> Food service</li> <li><input checked="" type="checkbox"/> Refuse areas</li> <li><input type="checkbox"/> Industrial processes</li> <li><input type="checkbox"/> Outdoor storage of equipment or materials</li> <li><input type="checkbox"/> Vehicle and Equipment Cleaning</li> <li><input type="checkbox"/> Vehicle/Equipment Repair and Maintenance</li> <li><input type="checkbox"/> Fuel Dispensing Areas</li> <li><input type="checkbox"/> Loading Docks</li> <li><input type="checkbox"/> Fire Sprinkler Test Water</li> <li><input type="checkbox"/> Miscellaneous Drain or Wash Water</li> <li><input checked="" type="checkbox"/> Plazas, sidewalks, and parking lots</li> </ul>	<ul style="list-style-type: none"> <li><input checked="" type="checkbox"/> Yes</li> <li><input type="checkbox"/> Yes</li> <li><input type="checkbox"/> Yes</li> <li><input type="checkbox"/> Yes</li> <li><input checked="" type="checkbox"/> Yes</li> <li><input type="checkbox"/> Yes</li> <li><input type="checkbox"/> Yes</li> <li><input checked="" type="checkbox"/> Yes</li> <li><input type="checkbox"/> Yes</li> <li><input type="checkbox"/> Yes</li> <li><input type="checkbox"/> Yes</li> <li><input type="checkbox"/> Yes</li> <li><input type="checkbox"/> Yes</li> <li><input type="checkbox"/> Yes</li> <li><input type="checkbox"/> Yes</li> <li><input checked="" type="checkbox"/> Yes</li> </ul>	<ul style="list-style-type: none"> <li><input type="checkbox"/> No</li> <li><input type="checkbox"/> No</li> <li><input type="checkbox"/> No</li> <li><input type="checkbox"/> No</li> <li><input type="checkbox"/> No</li> <li><input type="checkbox"/> No</li> <li><input type="checkbox"/> No</li> <li><input type="checkbox"/> No</li> <li><input type="checkbox"/> No</li> <li><input type="checkbox"/> No</li> <li><input type="checkbox"/> No</li> <li><input type="checkbox"/> No</li> <li><input type="checkbox"/> No</li> <li><input type="checkbox"/> No</li> <li><input type="checkbox"/> No</li> <li><input type="checkbox"/> No</li> </ul>	<ul style="list-style-type: none"> <li><input type="checkbox"/> N/A</li> <li><input checked="" type="checkbox"/> N/A</li> <li><input checked="" type="checkbox"/> N/A</li> <li><input checked="" type="checkbox"/> N/A</li> <li><input type="checkbox"/> N/A</li> <li><input checked="" type="checkbox"/> N/A</li> <li><input checked="" type="checkbox"/> N/A</li> <li><input type="checkbox"/> N/A</li> <li><input checked="" type="checkbox"/> N/A</li> <li><input checked="" type="checkbox"/> N/A</li> <li><input checked="" type="checkbox"/> N/A</li> <li><input checked="" type="checkbox"/> N/A</li> <li><input checked="" type="checkbox"/> N/A</li> <li><input checked="" type="checkbox"/> N/A</li> <li><input checked="" type="checkbox"/> N/A</li> <li><input checked="" type="checkbox"/> N/A</li> <li><input type="checkbox"/> N/A</li> </ul>
Discussion / justification if SC-6 not implemented. Clearly identify which sources of runoff pollutants are discussed. Justification must be provided for <u>all</u> "No" answers shown above.			

<b>Site Design BMP Checklist for All Development Projects (Standard Projects and Priority Development Projects)</b>		<b>Form I-5 Model BMP Design Manual [August 31, 2015]</b>	
<b>Project Identification</b>			
Project Name: St John the Baptizer Ukrainian Catholic Church			
Permit Application Number			
<b>Site Design BMPs</b>			
All development projects must implement site design BMPs SD-1 through SD-8 where applicable and feasible. See Chapter 4 and Appendix E of the Model BMP Design Manual for information to implement site design BMPs shown in this checklist.			
Answer each category below pursuant to the following.			
<ul style="list-style-type: none"> <li>• "Yes" means the project will implement the site design BMP as described in Chapter 4 and/or Appendix E of the Model BMP Design Manual. Discussion / justification is not required.</li> <li>• "No" means the BMP is applicable to the project but it is not feasible to implement. Discussion / justification must be provided.</li> <li>• "N/A" means the BMP is not applicable at the project site because the project does not include the feature that is addressed by the BMP (e.g., the project site has no existing natural areas to conserve). Discussion / justification may be provided.</li> </ul>			
<b>Site Design Requirement</b>		<b>Applied?</b>	
<b>SD-1</b> Maintain Natural Drainage Pathways and Hydrologic Features		<input checked="" type="checkbox"/> Yes	<input type="checkbox"/> No <input type="checkbox"/> N/A
Discussion / justification if SD-1 not implemented:			
<b>SD-2</b> Conserve Natural Areas, Soils, and Vegetation		<input checked="" type="checkbox"/> Yes	<input type="checkbox"/> No <input type="checkbox"/> N/A
Discussion / justification if SD-2 not implemented:			
<b>SD-3</b> Minimize Impervious Area		<input checked="" type="checkbox"/> Yes	<input type="checkbox"/> No <input type="checkbox"/> N/A
Discussion / justification if SD-3 not implemented:			
<b>SD-4</b> Minimize Soil Compaction		<input checked="" type="checkbox"/> Yes	<input type="checkbox"/> No <input type="checkbox"/> N/A
Discussion / justification if SD-4 not implemented:			
<b>SD-5</b> Impervious Area Dispersion		<input checked="" type="checkbox"/> Yes	<input type="checkbox"/> No <input type="checkbox"/> N/A
Discussion / justification if SD-5 not implemented:			

**Form I-5 Page 2 of 2, Form Template Date: August 31, 2015**

<b>Site Design Requirement</b>	<b>Applied?</b>		
<b>SD-6</b> Runoff Collection	<input type="checkbox"/> Yes	<input type="checkbox"/> No	<input checked="" type="checkbox"/> N/A
Discussion / justification if SD-6 not implemented: Runoff collection not feasible per limited space and architectural design.			
<b>SD-7</b> Landscaping with Native or Drought Tolerant Species	<input checked="" type="checkbox"/> Yes	<input type="checkbox"/> No	<input type="checkbox"/> N/A
Discussion / justification if SD-7 not implemented:			
<b>SD-8</b> Harvesting and Using Precipitation	<input type="checkbox"/> Yes	<input checked="" type="checkbox"/> No	<input type="checkbox"/> N/A
Discussion / justification if SD-8 not implemented: Harvest and use is considered to be infeasible per Form I-7			

<b>Summary of PDP Structural BMPs</b>	<b>Form I-6 (PDPs)</b> Model BMP Design Manual [August 31, 2015]
<b>Project Identification</b>	
Project Name: St John the Baptizer Ukrainian Catholic Church	
Permit Application Number	
<b>PDP Structural BMPs</b>	
<p>All PDPs must implement structural BMPs for storm water pollutant control (see Chapter 5 of the BMP Design Manual). Selection of PDP structural BMPs for storm water pollutant control must be based on the selection process described in Chapter 5. PDPs subject to hydromodification management requirements must also implement structural BMPs for flow control for hydromodification management (see Chapter 6 of the BMP Design Manual). Both storm water pollutant control and flow control for hydromodification management can be achieved within the same structural BMP(s).</p> <p>PDP structural BMPs must be verified by the local jurisdiction at the completion of construction. This may include requiring the project owner or project owner's representative and engineer of record to certify construction of the structural BMPs (see Section 1.12 of the BMP Design Manual). PDP structural BMPs must be maintained into perpetuity, and the local jurisdiction must confirm the maintenance (see Section 7 of the BMP Design Manual).</p> <p>Use this form to provide narrative description of the general strategy for structural BMP implementation at the project site in the box below. Then complete the PDP structural BMP summary information sheet (page 3 of this form) for each structural BMP within the project (copy the BMP summary information page as many times as needed to provide summary information for each individual structural BMP).</p> <p>Describe the general strategy for structural BMP implementation at the site. This information must describe how the steps for selecting and designing storm water pollutant control BMPs presented in Section 5.1 of the BMP Design Manual were followed, and the results (type of BMPs selected). For projects requiring hydromodification flow control BMPs, indicate whether pollutant control and flow control BMPs are integrated or separate.</p> <p><i>Based on the site specific infiltration analysis and Form I-8, the soils may be designed for partial infiltration, therefore Biofiltration with partial retention has been selected.</i></p> <p><i>The BMP device, is being sized to conform to pollutant control requirements only due the project is hydromodification control exempted. Refer to Attachment 1a.</i></p> <p><i>The runoff from walkways, landscape areas and driveways is concentrated in a valley ditch that convey runoff from the site to the BMP.</i></p> <p><i>The orifice of the BMP device has been sized to discharge not more than 10% of the 2-year runoff and the overflow will discharge into the existing headwall by a 12" PVC outlet pipe and discharge into an existing public storm drain at Carlton Oaks Dr.</i></p> <p><i>Refer to section and detail in Attachment 1a.</i></p>	

**(Page reserved for continuation of description of general strategy for structural BMP implementation at the site)**

(Continued from page 1)

**Structural BMP Summary Information**  
**(Copy this page as needed to provide information for each individual proposed structural BMP)**

Structural BMP ID No.: BF-A

Construction Plan Sheet No.

Type of structural BMP:

- Retention by harvest and use (HU-1)
- Retention by infiltration basin (INF-1)
- Retention by bioretention (INF-2)
- Retention by permeable pavement (INF-3)
- Partial retention by biofiltration with partial retention (PR-1)
- Biofiltration (BF-1)
- Biofiltration with Nutrient Sensitive Media Design (BF-2)
- Proprietary Biofiltration (BF-3) meeting all requirements of Appendix F
- Flow-thru treatment control with prior lawful approval to meet earlier PDP requirements (provide BMP type/description in discussion section below)
- Flow-thru treatment control included as pre-treatment/forebay for an onsite retention or biofiltration BMP (provide BMP type/description and indicate which onsite retention or biofiltration BMP it serves in discussion section below)
- Flow-thru treatment control with alternative compliance (provide BMP type/description in discussion section below)
- Detention pond or vault for hydromodification management
- Other (describe in discussion section below)

Purpose:

- Pollutant control only
- Hydromodification control only
- Combined pollutant control and hydromodification control
- Pre-treatment/forebay for another structural BMP
- Other (describe in discussion section below)

Who will certify construction of this BMP? Provide name and contact information for the party responsible to sign BMP verification forms if required by the [City Engineer] (See Section 1.12 of the BMP Design Manual)	Jose Raul Gomez P.E. (619) 210-3371 Joseraulgomez1958@gmail.com
Who will be the final owner of this BMP?	St John the Baptizer Ukrainian Catholic Church
Who will maintain this BMP into perpetuity?	St John the Baptizer Ukrainian Catholic Church
What is the funding mechanism for maintenance?	St John the Baptizer Ukrainian Catholic Church

Structural BMP ID No.

Construction Plan Sheet No.

Discussion (as needed):

For drawings and calculations please refer to attachment 1a, DMA Exhibit, and attachments 1b and 1e for BMP sizing calculations.

## ATTACHMENT 1 BACKUP FOR PDP POLLUTANT CONTROL BMPS

*This is the cover sheet for Attachment 1.*

**Indicate which Items are Included behind this cover sheet:**

Attachment Sequence	Contents	Checklist
Attachment 1a	DMA Exhibit (Required)  See DMA Exhibit Checklist on the back of this Attachment cover sheet.	<input checked="" type="checkbox"/> Included
Attachment 1b	Tabular Summary of DMAs Showing DMA ID matching DMA Exhibit, DMA Area, and DMA Type (Required)*  *Provide table in this Attachment OR on DMA Exhibit in Attachment 1a	<input checked="" type="checkbox"/> Included on DMA Exhibit in Attachment 1a <input type="checkbox"/> Included as Attachment 1b, separate from DMA Exhibit
Attachment 1c	Form I-7, Harvest and Use Feasibility Screening Checklist (Required unless the entire project will use infiltration BMPs)  Refer to Appendix B.3-1 of the BMP Design Manual to complete Form I-7.	<input checked="" type="checkbox"/> Included <input type="checkbox"/> Not included because the entire project will use infiltration BMPs
Attachment 1d	Form I-8, Categorization of Infiltration Feasibility Condition (Required unless the project will use harvest and use BMPs)  Refer to Appendices C and D of the BMP Design Manual to complete Form I-8.	<input checked="" type="checkbox"/> Included <input type="checkbox"/> Not included because the entire project will use harvest and use BMPs
Attachment 1e	Pollutant Control BMP Design Worksheets / Calculations (Required)  Refer to Appendices B and E of the BMP Design Manual for structural pollutant control BMP design guidelines	<input checked="" type="checkbox"/> Included



*Use this checklist to ensure the required information has been included on the DMA Exhibit:*

The DMA Exhibit must identify:

- Underlying hydrologic soil group
- Approximate depth to groundwater
- Existing natural hydrologic features ( watercourses, seeps, springs, wetlands)
- Critical coarse sediment yield areas to be protected
- Existing topography and impervious areas
- Existing and proposed site drainage network and connections to drainage offsite
- Proposed demolition
- Proposed grading
- Proposed impervious features
- Proposed design features and surface treatments used to minimize imperviousness
- Drainage management area (DMA) boundaries, DMA ID numbers, and DMA areas (square footage or acreage), and DMA type (i.e., drains to BMP, self-retaining, or self-mitigating)
- Potential pollutant source areas and corresponding required source controls (see Chapter 4, Appendix E.1, and Form I-3B)
- Structural BMPs (identify location, type of BMP, and size/detail)

Attachment 1a  
**DMA Exhibit**



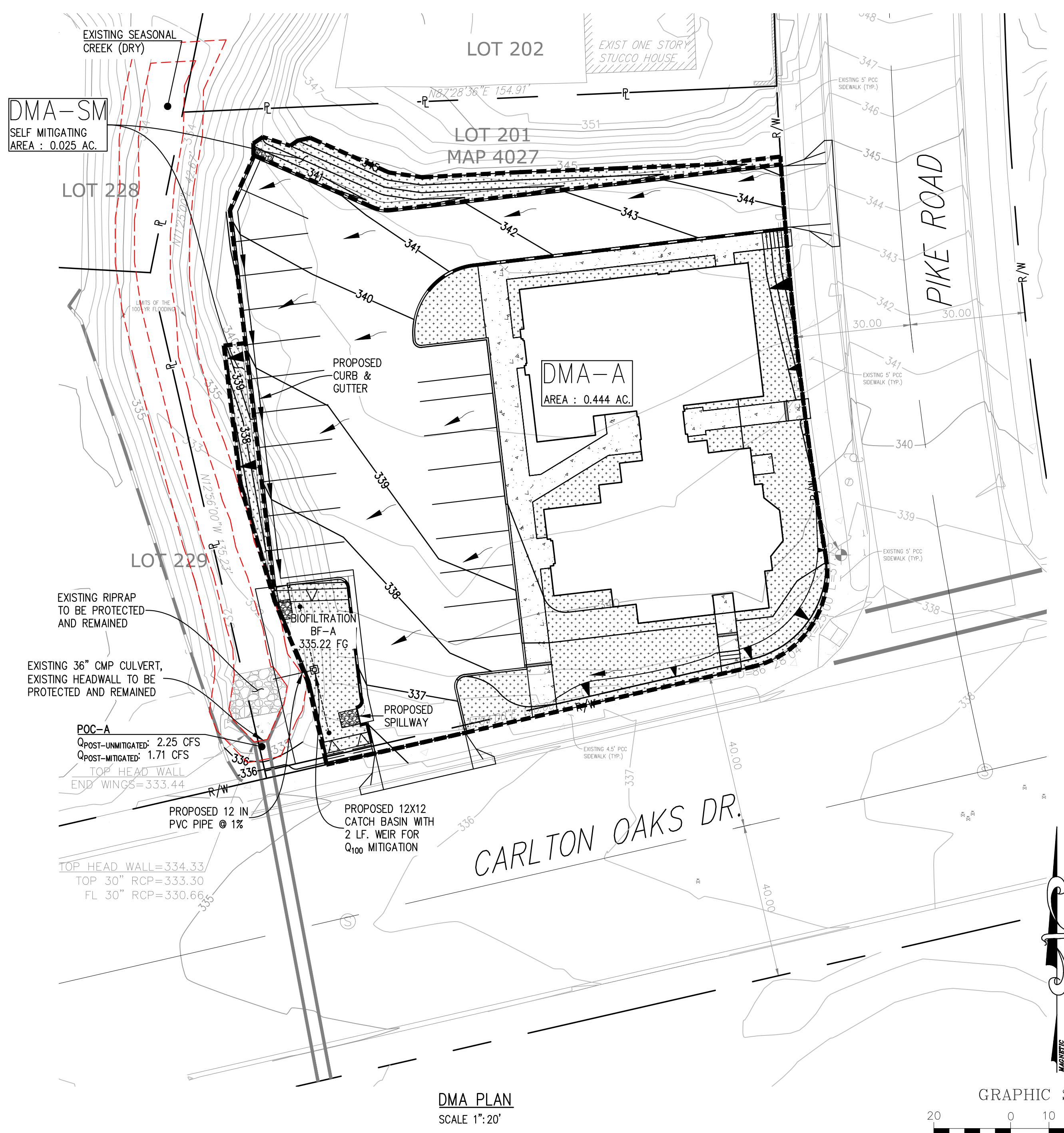

**DMA-SM**  
SELF MITIGATING  
AREA : 0.025 AC.

**DMA-A**  
AREA : 0.444 AC.

**DMA PLAN**  
SCALE 1":20'

- DMA LEGEND**
- AC PAVING (IMPERVIOUS)
  - HARDSCAPE (IMPERVIOUS)
  - BUILDING (IMPERVIOUS)
  - SLOPE AND LANDSCAPING (PERVIOUS)
  - DMA BOUNDARY
  - STORMDRAIN FLOW
  - SURFACE FLOW

**BMP AREA SUMMARY**

AREA PROVIDED	469 SF
AREA REQUIRED	449 SF

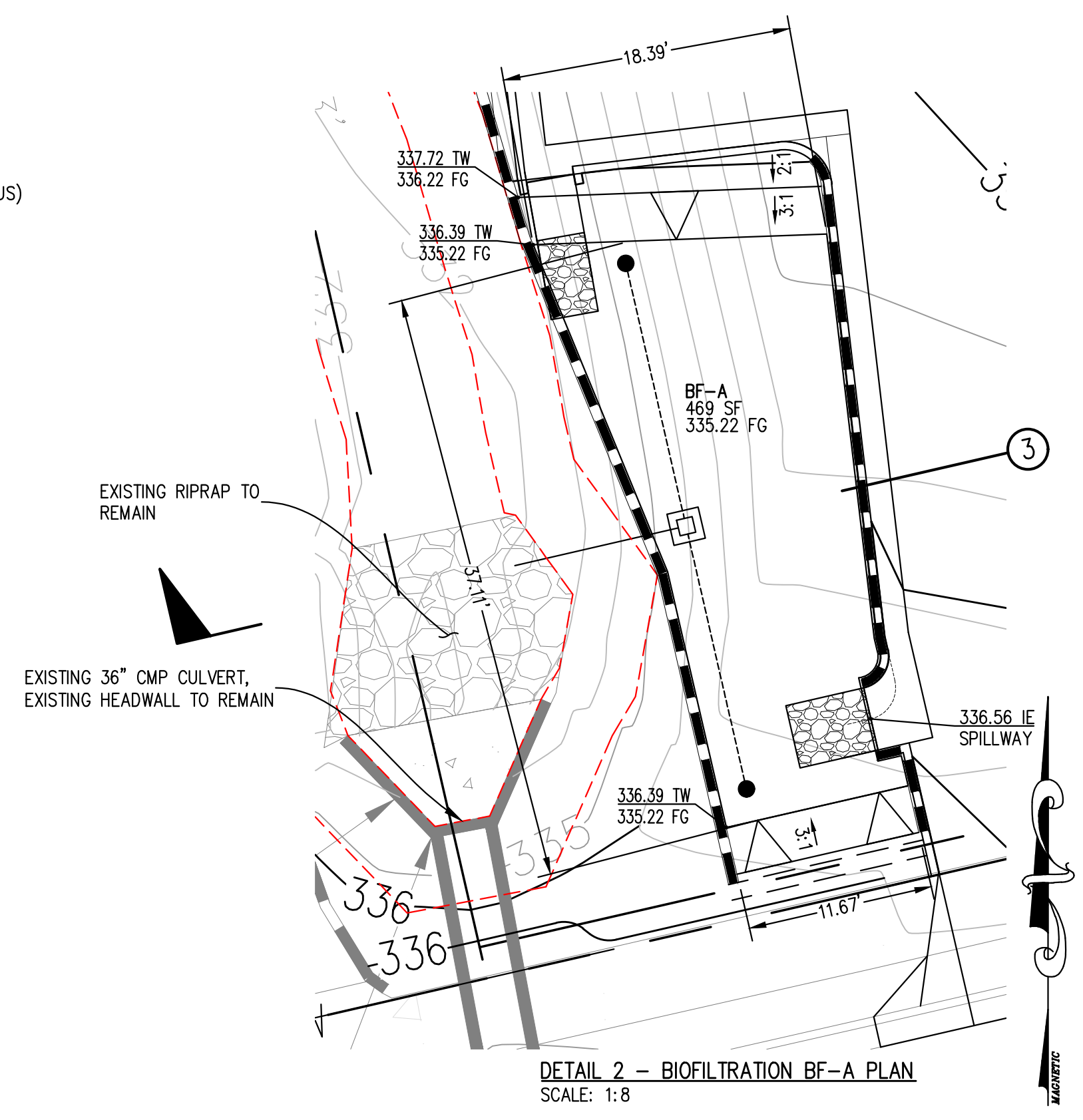
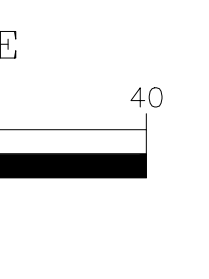

**DETAIL 2 - BIOFILTRATION BF-A PLAN**  
SCALE: 1:8

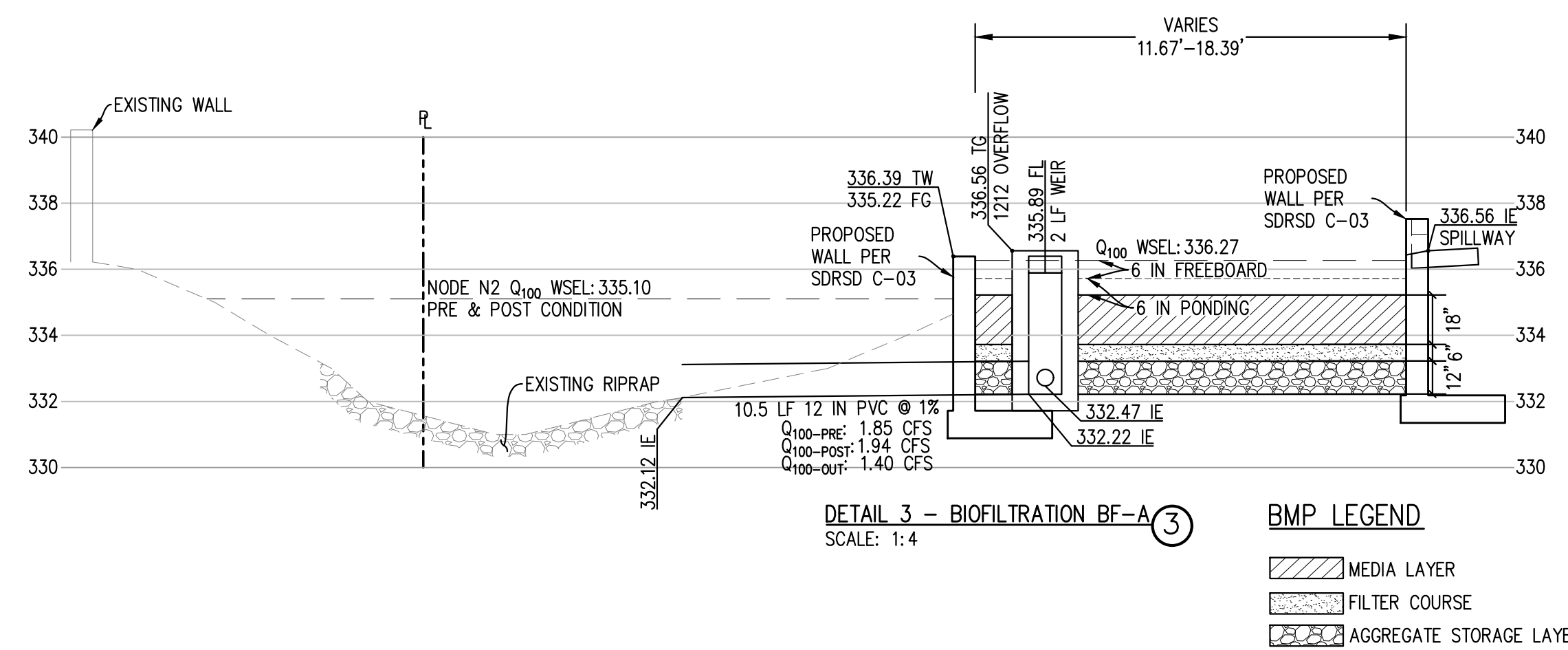

**DETAIL 3 - BIOFILTRATION BF-A**  
SCALE: 1:4

- BMP LEGEND**
- MEDIA LAYER
  - FILTER COURSE
  - AGGREGATE STORAGE LAYER

**BIOFILTRATION BASIN  
SOIL MEDIA SPECIFICATION**

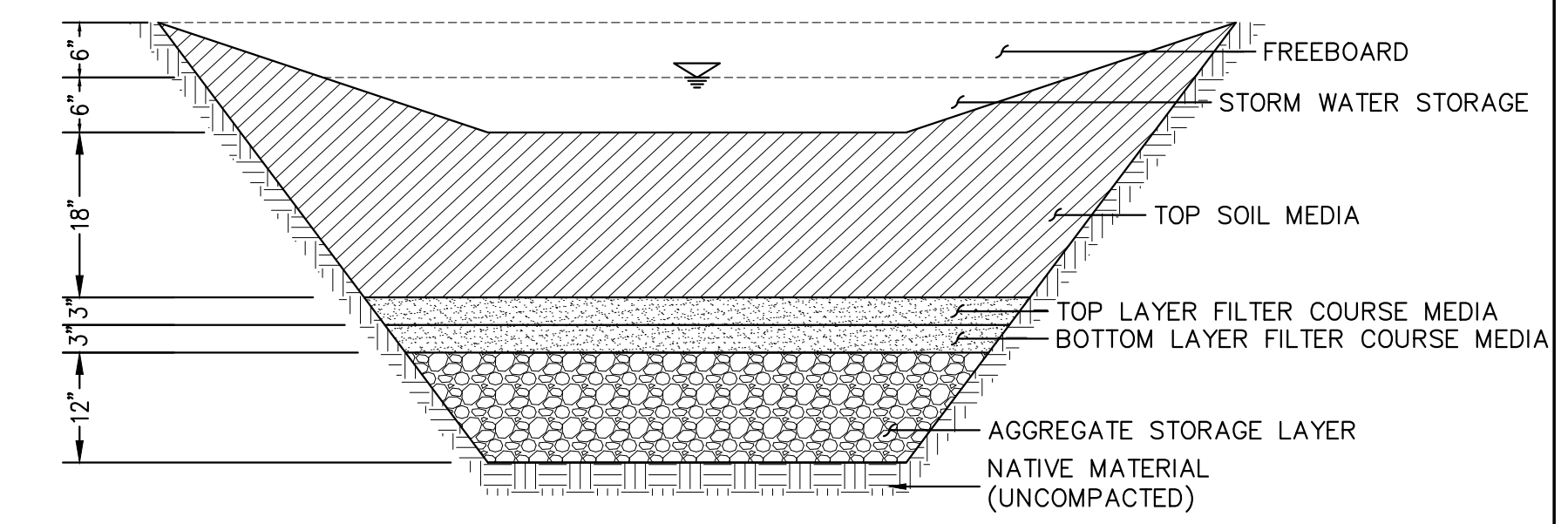

**TOP SOIL MEDIA**  
TOP SOIL MEDIA SHALL CONSIST OF THE FOLLOWING COMPONENTS:  
**60% TO 80%** WASHED SAND THAT MEETS GRADATION REQUIREMENTS PER TABLE 803-3.2, BELOW.

**TABLE 803-3.2**

SIEVE SIZE (ASTM D422)	PERCENTAGE PASSING SIEVE (BY WEIGHT)	
	MINIMUM	MAXIMUM
0.375 IN	100	100
NO.4	90	100
NO.8	70	100
NO.16	40	95
NO.30	15	70
NO.40	5	55
NO.100	0	15
NO.200	0	5

**UP TO 20%** OF TOP SOIL THAT MEETS GRADATION REQUIREMENTS PER TABLE 803-4.2

**TABLE 803-4.2**

TEXTURAL CLASS (ASTM D422)	SIZE RANGE	MASS FRACTION (PERCENT)
GRAVEL	LARGER THAN 2MM	0 TO 25 OF TOTAL SAMPLE
CLAY	SMALLER THAN 0.005MM	0 TO 15 OF NON GRAVEL FRACTION

**UP TO 20%** OF COMPOST THAT MEETS GRADATION REQUIREMENTS PER TABLE 803-5.1.1

**TABLE 803-5.1.1**

SIEVE SIZE (ASTM D422)	PERCENT PASSING SIEVE (BY WEIGHT)
1/2"	97 TO 100
2 MM	40 TO 90

**FILTER COURSE MEDIA**  
TOP LAYER FILTER COURSE: SHALL BE 3 INCHES THICK AND CONSIST OF THOROUGHLY WASHED CHOKER SAND THAT MEETS ASTM C33 AND AS DETAILED IN TABLE F.4-2 OF CITY OF SAN DIEGO STORM WATER STANDARDS MANUAL

**TABLE F.4-2**

SIEVE SIZE	PERCENTAGE PASSING SIEVE CHOKER SAND - ASTM C33
0.375 IN	100
NO.4	95-100
NO.8	80-100
NO.16	50-85
NO.30	25-60
NO.50	5-30
NO.100	0-10
NO.200	0-3

**BOTTOM LAYER FILTER COURSE:** SHALL BE 3 INCHES THICK AND CONSIST OF THOROUGHLY WASHED ASTM No.8 AGGREGATE MATERIAL THAT CONFORMS TO GRADATION LIMITS CONTAINED IN TABLE F.4-1 OF CITY OF SAN DIEGO STORM WATER STANDARDS MANUAL

**TABLE F.4-1**

SIEVE SIZE	PERCENTAGE PASSING SIEVE ASTM No.8
1.5 IN	100
0.375 IN	85-100
NO.4	10-30
NO.8	0-10
NO.16	0-5
NO.50	-

**OPEN-GRADED AGGREGATE STORAGE LAYER**  
THE OPEN-GRADED AGGREGATE MATERIAL SHALL BE PLACED BELOW THE FILTER COURSE AND HAVE A DEPTH OF 18 INCHES. THE MATERIAL SHALL CONSIST OF AASHTO No.57, OPEN GRADED AGGREGATE THAT CONFORMS TO GRADATION LIMITS PER TABLE F.4-1 OF THE CITY OF SAN DIEGO STORM WATER STANDARDS MANUAL.

**TABLE F.4-1**

SIEVE SIZE	PERCENTAGE PASSING SIEVE AASHTO No.57
1.5 IN	100
1 IN	95-100
0.75 IN	-
0.5 IN	25-60
0.375 IN	-
NO.4	10 MAX.
NO.8	5 MAX.

**Tabular Summary of DMAs**

DMA Unique Identifier	Area (acres)	Impervious Area (acres)	% Imp	HSG	Area Weighted Runoff Coefficient	DCV (cubic feet)	Treated By (BMP ID)	Pollutant Control Type	Drains to (POC ID)
BASIN A	0.444	0.348	78%	D	0.77	621	BF-A	BF-1	POC-A
BASIN SM	0.025	0	0%	D	0.30	NA	SELF	MITIGATING	NA

**DMA NOTES**

- 1 THE UNDERLYING SOIL GROUP IS D
- 2 THE APPROXIMATE DEPTH TO GROUND WATER IS HIGHER THAN 40 FEET.
- 3 THERE IS A DRY AND SEASONAL CREEK IN THE REAR OF THE PROPERTY.
- 4 THERE ARE NO CRITICAL COARSE SEDIMENT YIELD AREAS TO BE PROTECTED ONSITE.

**Attachment 1b**  
**DMA Summary**





**Attachment 1c**  
**Form I-7, Harvest and Use Feasibility Screening Checklist**

# Harvest and Use Feasibility Checklist

Form I-7

1. Is there a demand for harvested water (check all that apply) at the project site that is reliably present during the wet season?

- Toilet and urinal flushing
- Landscape irrigation
- Other: \_\_\_\_\_

2. If there is a demand; estimate the anticipated average wet season demand over a period of 36 hours. Guidance for planning level demand calculations for toilet/urinal flushing and landscape irrigation is provided in Section B.3.2.

Land use type: Neighborhood Commercial (Per City of Santee General Plan, Land Use Map, Figure 1-1)

Toilet flushing:  $(9.0+6.7)/2 = 7.85$  (average Commercial & School)  
 Urinals:  $(2.11+3.5)/2 = 2.81$  (average Commercial & School)  
 Visitor factor:  $(1.4+6.4)/2 = 3.9$  (average Commercial & School)  
 Water efficiency factor: 0.5 (average Commercial & School)

Daily Demand =  $(7.85 + 2.81) \text{ GPD} * 3.9 * 0.5 * 80 \text{ persons} = 1,663 \text{ GPD}$ .  
 36-hour demand =  $1.5 * 1,663 \text{ GPD} = 2,494 \text{ gl} = 2,494 \text{ gl} / 7.48 \text{ [gl/cf]} = 333 \text{ cubic-feet}$ .

3. Calculate the DCV using worksheet B-2.1.

85th percentile 24-hr storm depth	d = 0.50	inches
Area tributary to BMP (s)	A = 0.444	acres
Area weighted runoff factor	C = 0.77	unitless
Trees Credit Volume	TCV = -	cubic-feet
Rain Barrels Credit Volume	RCV = -	cubic-feet

Calculated DCV =  $(3630 * C * d * A) - \text{TCV} - \text{RCV} \rightarrow \text{DCV} = 621 \text{ cubic-feet}$

3a. Is the 36 hour demand greater than or equal to the DCV?

- Yes /  No 



Harvest and use appears to be feasible. Conduct more detailed evaluation and sizing calculations to confirm that DCV can be used at an adequate rate to meet drawdown criteria.

3b. Is the 36 hour demand greater than 0.25DCV but less than the full DCV?

- Yes /  No 



Harvest and use may be feasible. Conduct more detailed evaluation and sizing calculations to determine feasibility. Harvest and use may only be able to be used for a portion of the site, or (optionally) the storage may need to be upsized to meet long term capture targets while draining in longer than 36 hours.

3c. Is the 36 hour demand less than 0.25DCV?

- Yes



Harvest and use is considered to be infeasible.

# Harvest and Use Feasibility Checklist

Form I-7

1. Is there a demand for harvested water (check all that apply) at the project site that is reliably present during the wet season?

- Toilet and urinal flushing
- Landscape irrigation
- Other: \_\_\_\_\_

2. If there is a demand; estimate the anticipated average wet season demand over a period of 36 hours. Guidance for planning level demand calculations for toilet/urinal flushing and landscape irrigation is provided in Section B.3.2.

Zone (6)

$$ET_{wet} = 2.4 + 1.86 + 1.86 + 2.24 + 3.41 + 4.8 = 16.57 / 6 = 2.76 \text{ inches/month}$$

Plant factor, PF = 0.3, Irrigation Efficiency, IE = 0.90, Special Landscape Area, SLA = 0, Hydrozone Area, HA = 9,259 s.f. = 0.212 ac

$$ETWU = ET_{wet} (\sum(PF \times HA) / IE + SLA) \times 0.015 = 2.76 ((0.3 \times 9,259 / 0.9) + 0) \times 0.015 = 128 \text{ gpd}$$

$$\text{Convert to 36 hour volumes} = 128 \text{ gpd} \times 1.5 = 192 \text{ g} / 36 \text{ hours} = 5.3 \text{ cubic feet}$$

3. Calculate the DCV using worksheet B-2.1.

85th percentile 24-hr storm depth	d = 0.50	inches
Area tributary to BMP (s)	A = 0.444	acres
Area weighted runoff factor	C = 0.77	unitless
Trees Credit Volume	TCV = -	cubic-feet
Rain Barrels Credit Volume	RCV = -	cubic-feet

$$\text{Calculated DCV} = (3630 \times C \times d \times A) - \text{TCV} - \text{RCV} \rightarrow \text{DCV} = \mathbf{621 \text{ cubic-feet}}$$

3a. Is the 36 hour demand greater than or equal to the DCV?

- Yes /  No



Harvest and use appears to be feasible. Conduct more detailed evaluation and sizing calculations to confirm that DCV can be used at an adequate rate to meet drawdown criteria.

3b. Is the 36 hour demand greater than 0.25DCV but less than the full DCV?

- Yes /  No



Harvest and use may be feasible. Conduct more detailed evaluation and sizing calculations to determine feasibility. Harvest and use may only be able to be used for a portion of the site, or (optionally) the storage may need to be upsized to meet long term capture targets while draining in longer than 36 hours.

3c. Is the 36 hour demand less than 0.25DCV?

- Yes



Harvest and use is considered to be infeasible.



**Attachment 1d**  
**Form I-8, Categorization of Infiltration Feasibility Condition**

**Categorization of Infiltration Feasibility Condition**

Form I-8

**Part 1 - Full Infiltration Feasibility Screening Criteria**

**Would infiltration of the full design volume be feasible from a physical perspective without any undesirable consequences that cannot be reasonably mitigated?**

Criteria	Screening Question	Yes	No
1	<b>Is the estimated reliable infiltration rate below proposed facility locations greater than 0.5 inches per hour?</b> The response to this Screening Question shall be based on a comprehensive evaluation of the factors presented in Appendix C.2 and Appendix D.		X

Provide basis:

Based on a site specific infiltration analysis "Preliminary Geotechnical Evaluation, Proposed Church Building, APN 380-112-08-00, Santee California" project number 3721-SD, dated September 13, 2021 prepared by GeoTek, Inc., the infiltration rate for the proposed basin in 0.10 and 0.04 inches per hour. This does not include the final designed factor of safety.

Summarize findings of studies; provide reference to studies, calculations, maps, data sources, etc. Provide narrative discussion of study/data source applicability.

2	<b>Can infiltration greater than 0.5 inches per hour be allowed without increasing risk of geotechnical hazards (slope stability, groundwater mounding, utilities, or other factors) that cannot be mitigated to an acceptable level?</b> The response to this Screening Question shall be based on a comprehensive evaluation of the factors presented in Appendix C.2.		
---	--	--	--

Provide basis:

Summarize findings of studies; provide reference to studies, calculations, maps, data sources, etc. Provide narrative discussion of study/data source applicability.

**Form I-8 Page 2 of 4**

Criteria	Screening Question	Yes	No
3	<b>Can infiltration greater than 0.5 inches per hour be allowed without increasing risk of groundwater contamination (shallow water table, storm water pollutants or other factors) that cannot be mitigated to an acceptable level?</b> The response to this Screening Question shall be based on a comprehensive evaluation of the factors presented in Appendix C.3.		
<p>Provide basis:</p> <p>Summarize findings of studies; provide reference to studies, calculations, maps, data sources, etc. Provide narrative discussion of study/data source applicability.</p>			
4	<b>Can infiltration greater than 0.5 inches per hour be allowed without causing potential water balance issues such as change of seasonality of ephemeral streams or increased discharge of contaminated groundwater to surface waters?</b> The response to this Screening Question shall be based on a comprehensive evaluation of the factors presented in Appendix C.3.		
<p>Provide basis:</p> <p>Summarize findings of studies; provide reference to studies, calculations, maps, data sources, etc. Provide narrative discussion of study/data source applicability.</p>			
<b>Part 1 Result *</b>	<p>If all answers to rows 1 - 4 are “<b>Yes</b>” a full infiltration design is potentially feasible. The feasibility screening category is <b>Full Infiltration</b></p> <p>If any answer from row 1-4 is “<b>No</b>”, infiltration may be possible to some extent but would not generally be feasible or desirable to achieve a “full infiltration” design. Proceed to Part 2</p>	<b>No</b>	

\*To be completed using gathered site information and best professional judgment considering the definition of MEP in the MS4 Permit. Additional testing and/or studies may be required by Agency/Jurisdictions to substantiate findings

**Form I-8 Page 3 of 4**

**Part 2 – Partial Infiltration vs. No Infiltration Feasibility Screening Criteria**

**Would infiltration of water in any appreciable amount be physically feasible without any negative consequences that cannot be reasonably mitigated?**

Criteria	Screening Question	Yes	No
5	<b>Do soil and geologic conditions allow for infiltration in any appreciable rate or volume?</b> The response to this Screening Question shall be based on a comprehensive evaluation of the factors presented in Appendix C.2 and Appendix D.	X	

Provide basis:

**Based on a site specific infiltration analysis "Preliminary Geotechnical Evaluation, Proposed Church Building, APN 380-112-08-00, Santee California" project number 3721-SD, dated September 13, 2021 prepared by GeoTek, Inc., the infiltration rate for the proposed basin in 0.10 and 0.04 inches per hour. This does not include the final designed factor of safety.**

Summarize findings of studies; provide reference to studies, calculations, maps, data sources, etc. Provide narrative discussion of study/data source applicability and why it was not feasible to mitigate low infiltration rates.

6	<b>Can Infiltration in any appreciable quantity be allowed without increasing risk of geotechnical hazards (slope stability, groundwater mounding, utilities, or other factors) that cannot be mitigated to an acceptable level?</b> The response to this Screening Question shall be based on a comprehensive evaluation of the factors presented in Appendix C.2.	X	
---	---	---	--

Provide basis:

**Provided the approved geotechnical recommendations are implemented into the design and construction of the stormwater management system, increased risk of geotechnical hazards are null.**

Summarize findings of studies; provide reference to studies, calculations, maps, data sources, etc. Provide narrative discussion of study/data source applicability and why it was not feasible to mitigate low infiltration rates.

**Form I-8 Page 4 of 4**

Criteria	Screening Question	Yes	No
7	<p><b>Can Infiltration in any appreciable quantity be allowed without posing significant risk for groundwater related concerns (shallow water table, storm water pollutants or other factors)?</b> The response to this Screening Question shall be based on a comprehensive evaluation of the factors presented in Appendix C.3.</p>	X	
<p>Provide basis:</p> <p align="center"><b>Yes, see section 5.3.1 Stormwater Infiltration of the project's preliminary soils report</b></p> <p>Summarize findings of studies; provide reference to studies, calculations, maps, data sources, etc. Provide narrative discussion of study/data source applicability and why it was not feasible to mitigate low infiltration rates.</p>			
8	<p><b>Can infiltration be allowed without violating downstream water rights?</b> The response to this Screening Question shall be based on a comprehensive evaluation of the factors presented in Appendix C.3.</p>	X	
<p>Provide basis:</p> <p align="center"><b>Yes, see section 5.3.1 Stormwater Infiltration of the project's preliminary soils report</b></p> <p>Summarize findings of studies; provide reference to studies, calculations, maps, data sources, etc. Provide narrative discussion of study/data source applicability and why it was not feasible to mitigate low infiltration rates.</p>			
<b>Part 2 Result*</b>	<p>If all answers from row 1-4 are yes then partial infiltration design is potentially feasible. The feasibility screening category is <b>Partial Infiltration</b>.</p> <p>If any answer from row 5-8 is no, then infiltration of any volume is considered to be <b>infeasible</b> within the drainage area. The feasibility screening category is <b>No Infiltration</b>.</p>		<b>Partial Infiltration</b>

\*To be completed using gathered site information and best professional judgment considering the definition of MEP in the MS4 Permit. Additional testing and/or studies may be required by Agency/Jurisdictions to substantiate findings

Attachment 1e  
**Pollutant Control BMP Design Worksheets / Calculations**

## Appendix B: Storm Water Pollutant Control Hydrologic Calculations and Sizing Methods

### B.1 DCV

DCV is defined as the volume of storm water runoff resulting from the 85<sup>th</sup> percentile, 24-hr storm event. The following hydrologic method shall be used to calculate the DCV:

$$DCV = C \times d \times A \times 43,560 \text{ sf/ac} \times 1/12 \text{ in/ft}$$
$$DCV = 3,630 \times C \times d \times A$$

Where:

DCV = Design Capture Volume in cubic feet

C = Runoff factor (unitless); refer to section B.1.1

d = 85<sup>th</sup> percentile, 24-hr storm event rainfall depth (inches), refer to section B.1.3

A = Tributary area (acres) which includes the total area draining to the BMP, including any offsite or onsite areas that comingles with project runoff and drains to the BMP. Refer to Chapter 3, Section 3.3.3 for additional guidance. Street redevelopment projects consult section 1.4.3.

#### B.1.1 Runoff Factor

Estimate the area weighted runoff factor for the tributary area to the BMP using runoff factor (from Table B.1-1) and area of each surface type in the tributary area and the following equation:

$$C = \frac{\sum C_x A_x}{\sum A_x}$$

Where:

$C_x$  = Runoff factor for area X

$A_x$  = Tributary area X (acres)

These runoff factors apply to areas receiving direct rainfall only. For conditions in which runoff is routed onto a surface from an adjacent surface, see Section B.2 for determining composite runoff factors for these areas.

**Table 0-1: Runoff factors for surfaces draining to BMPs – Pollutant Control BMPs**

Surface	Runoff Factor
Roofs <sup>1</sup>	0.90
Concrete or Asphalt <sup>1</sup>	0.90
Unit Pavers (grouted) <sup>1</sup>	0.90
Decomposed Granite	0.30
Cobbles or Crushed Aggregate	0.30
Amended, Mulched Soils or Landscape	0.10
Compacted Soil (e.g., unpaved parking)	0.30

1. Surface is considered impervious and could benefit from use of Site Design BMPs and adjustment of the runoff factor per Section B.2.1.

## Appendix B: Storm Water Pollutant Control Hydrologic Calculations and Sizing Methods

Surface	Runoff Factor
Natural (A Soil)	0.10
Natural (B Soil)	0.14
Natural (C Soil)	0.23
Natural (D Soil)	0.30

### **Runoff Factor Per Appendix B.1.1**

	DMA-A	DMA-SM (Self-Mitigating)	C coefficient
Roofs [sf]	4,384	0	0.9
Concrete/Asphalt [sf]	10,769	0	0.9
Landscape (Soil D) [sf]	4,189	1,102	0.3
Total [sf]	19,342	1,102	(20,444 sf Disturbed area)

Weighted runoff factor (DMA-A only)

$$C = 0.9(4,384/19,342) + 0.9(10,769/19,342) + 0.3(4,189/19,342)$$

$$C = 0.77$$

Worksheet 0-1. DCV

Design Capture Volume		Worksheet B-2.1		
1	85 <sup>th</sup> percentile 24-hr storm depth from Figure B.1-1	d=	0.50	inches
2	Area tributary to BMP (s)	A=	0.444	acres
3	Area weighted runoff factor (estimate using Appendix B.1.1 and B.2.1)	C=	0.77	unitless
4	Street trees volume reduction	TCV=		cubic-feet
5	Rain barrels volume reduction	RCV=		cubic-feet
6	Calculate DCV = (3630 x C x d x A) – TCV - RCV	DCV=	621	cubic-feet



**Worksheet 0-1: Simple Sizing Method for Biofiltration BMPs**

Simple Sizing Method for Biofiltration BMPs		Worksheet B.5-1	
1	Remaining DCV after implementing retention BMPs	621	cubic-feet
<b>Partial Retention</b>			
2	Infiltration rate from Worksheet D.5-1 if partial infiltration is feasible	0.1	in/hr.
3	Allowable drawdown time for aggregate storage below the underdrain	36	hours
4	Depth of runoff that can be infiltrated [Line 2 x Line 3]	3.6	inches
5	Aggregate pore space	0.40	in/in
6	Required depth of gravel below the underdrain [Line 4/ Line 5]	9	inches
7	Assumed surface area of the biofiltration BMP	488	sq-ft
8	Media retained pore space	0.1	in/in
9	Volume retained by BMP $[(\text{Line 4} + (\text{Line 12} \times \text{Line 8}))/12] \times \text{Line 7}$	219.6	cubic-feet
10	DCV that requires biofiltration [Line 1 – Line 9]	401.4	cubic-feet
<b>BMP Parameters</b>			
11	Surface Ponding [6 inch minimum, 12 inch maximum]	6	inches
12	Media Thickness [18 inches minimum]	18	inches
13	Aggregate Storage above underdrain invert (12 inches typical) – use 0 inches for sizing if the aggregate is not over the entire bottom surface area	12	inches
14	Media available pore space	0.2	in/in
15	Media filtration rate to be used for sizing	5	in/hr.
<b>Baseline Calculations</b>			
16	Allowable Routing Time for sizing	6	hours
17	Depth filtered during storm [ Line 15 x Line 16]	30	inches
18	Depth of Detention Storage [Line 11 + (Line 12 x Line 14) + (Line 13 x Line 5)]	14.4	inches
19	Total Depth Treated [Line 17 + Line 18]	44.4	inches
<b>Option 1 – Biofilter 1.5 times the DCV</b>			
20	Required biofiltered volume [1.5 x Line 10]	602.1	cubic-feet
21	Required Footprint [Line 20/ Line 19] x 12	163	sq-ft
<b>Option 2 - Store 0.75 of remaining DCV in pores and ponding</b>			
22	Required Storage (surface + pores) Volume [0.75 x Line 10]	301	cubic-feet
23	Required Footprint [Line 22/ Line 18] x 12	251	sq-ft
<b>Footprint of the BMP</b>			
24	Area draining to the BMP	19,342	sq-ft
25	Adjusted Runoff Factor for drainage area (Refer to Appendix B.1 and B.2)	0.77	
26	Minimum BMP Footprint [Line 24 x Line 25 x 0.03]	447	sq-ft
25	Footprint of the BMP = Maximum(Minimum(Line 21, Line 23), Line 26)	447	sq-ft

**Note:** Line 7 is used to estimate the amount of volume retained by the BMP. Update assumed surface area in Line 7 until its equivalent to the required biofiltration footprint (either Line 21 or Line 23)

### B.5.1 Standard Biofiltration BMP Footprint Sizing Factors

Table B.5-1 provides the minimum surface area (percent of contributing impervious area) required to meet the performance standards for Biofiltration BMPs (Fact Sheet BF-1). Parameters used to develop the sizing factors presented in Table B.5-1 are listed below:

- Media filtration rate for sizing = 5.0 in/hr.; Minimum required media filtration rate.
- Routing Period of 6 hours which was based on 50<sup>th</sup> percentile storm duration for storms similar to 85<sup>th</sup> percentile rainfall depth. Estimated based on inspection of continuous rainfall data from Lake Wohlford, Lindbergh and Oceanside rain gages.
- 12 inches aggregate storage is assumed for developing the below sizing factors.
- Minimum required surface area of 3% of contributing area times adjusted runoff factor. Refer to Appendix B.5.2 for the basis for establishing this minimum surface area criterion.

**Table 0-1: Minimum Required Surface Area (Percent of contributing area times adjusted runoff factor) for BF-1**

85 <sup>th</sup> Percentile Rainfall Depth	Surface Ponding = 6" Media Thickness = 18"	Surface Ponding = 6" Media Thickness = 24"	Surface Ponding = 12" Media Thickness = 18"	Surface Ponding = 12" Media Thickness = 24"
0.55"	3.0%	3.0%	3.0%	3.0%
0.7"	3.0%	3.0%	3.0%	3.0%
0.85"	3.0%	3.0%	3.0%	3.0%
1"	3.2%	3.0%	3.0%	3.0%
1.25"	4.0%	3.8%	3.5%	3.4%
1.55"	4.9%	4.7%	4.4%	4.2%

In order to evaluate the parameters recommended for sizing biofiltration BMPs in Worksheet B.5-1 continuous simulations were performed using USEPA SWMM and default parameters listed in Appendix G for Lake Wohlford, Lindbergh and Oceanside rain gages. Estimated average annual captures for the size of the biofiltration BMPs estimated using Worksheet B.5-1 are presented in the Table B.5-2 below:

**Table 0-2: Average Annual Capture Results for the Three Rain Gages**

Rainfall gage	85 <sup>th</sup> Percentile Rainfall Depth)	Biofiltration Footprint for 1 acre impervious catchment =3%; Surface Ponding = 6"; Media Thickness = 18"	Average Annual Capture
Lake Wohlford	0.88"	1,307 sq. ft.	97%
Lindbergh	0.53"	1,307 sq. ft.	99%
Oceanside	0.76"	1,307 sq. ft.	97%

Note: Per Worksheet B.5-1 and the 85<sup>th</sup> percentile rainfall of the stations analyzed, the minimum biofiltration size criteria is the dominant criteria. Different surface ponding values and/or different 85<sup>th</sup> percentile storms may lead to higher values than those shown in this table.



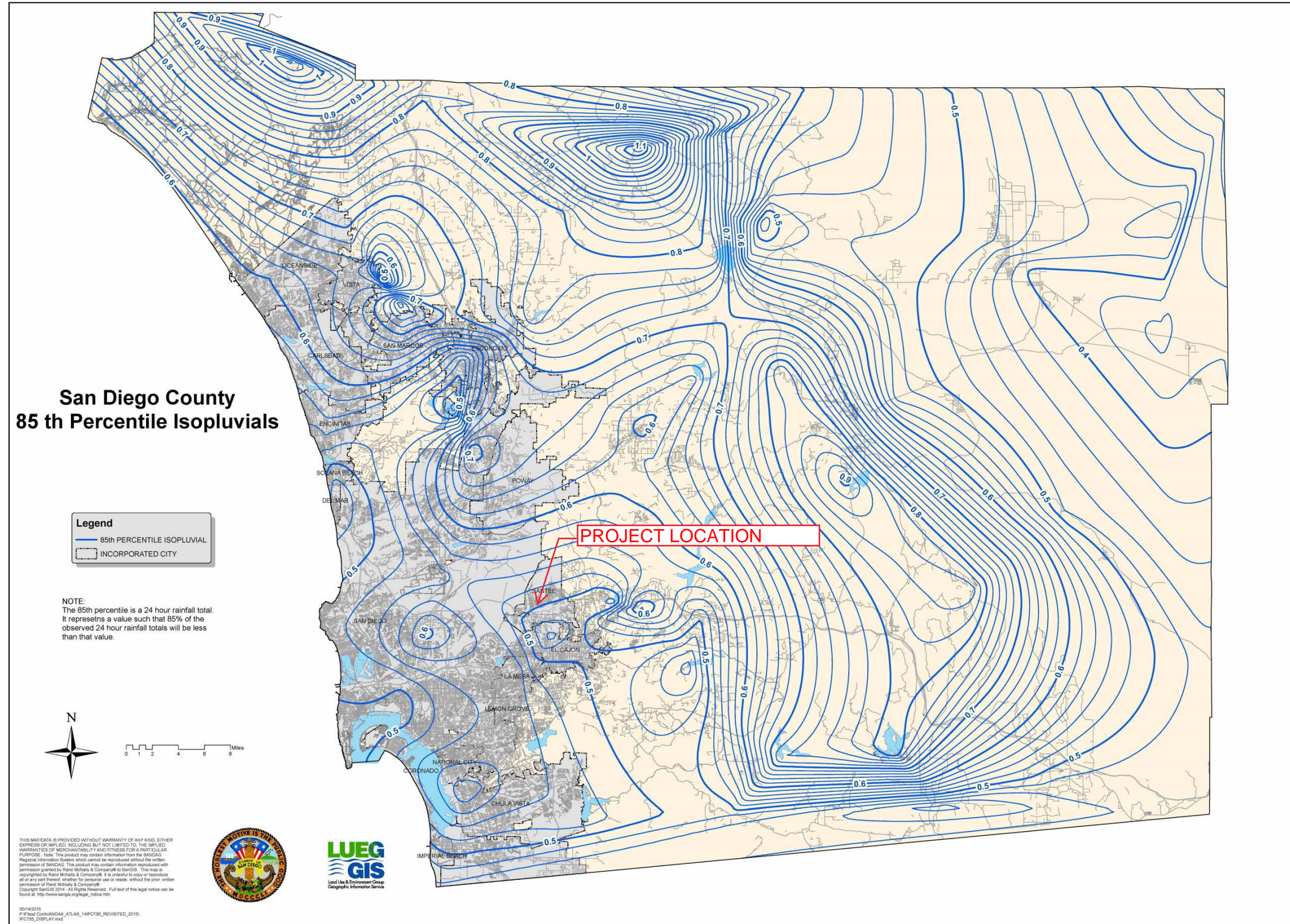

Figure B.1-1: 85th Percentile 24-hour Isopluvial Map



## ATTACHMENT 2 BACKUP FOR PDP HYDROMODIFICATION CONTROL MEASURES

*This is the cover sheet for Attachment 2.*

Mark this box if this attachment is empty because the project is exempt from PDP hydromodification management requirements.

**Indicate which Items are Included behind this cover sheet:**



Attachment Sequence	Contents	Checklist
Attachment 2a	Hydromodification Management Exhibit (Required)	<input type="checkbox"/> Included  See Hydromodification Management Exhibit Checklist on the back of this Attachment cover sheet.
Attachment 2b	Management of Critical Coarse Sediment Yield Areas (WMAA Exhibit is required, additional analyses are optional)  See Section 6.2 of the BMP Design Manual.	<input type="checkbox"/> Exhibit showing project drainage boundaries marked on WMAA Critical Coarse Sediment Yield Area Map (Required)  Optional analyses for Critical Coarse Sediment Yield Area Determination <input type="checkbox"/> 6.2.1 Verification of Geomorphic Landscape Units Onsite <input type="checkbox"/> 6.2.2 Downstream Systems Sensitivity to Coarse Sediment <input type="checkbox"/> 6.2.3 Optional Additional Analysis of Potential Critical Coarse Sediment Yield Areas Onsite
Attachment 2c	Geomorphic Assessment of Receiving Channels (Optional) See Section 6.3.4 of the BMP Design Manual.	<input type="checkbox"/> Not performed <input type="checkbox"/> Included <input type="checkbox"/> Submitted as separate stand-alone document
Attachment 2d	Flow Control Facility Design, including Structural BMP Drawdown Calculations and Overflow Design Summary (Required) See Chapter 6 and Appendix G of the BMP Design Manual	<input type="checkbox"/> Included <input type="checkbox"/> Submitted as separate stand-alone document
Attachment 2e	Vector Control Plan (Required when structural BMPs will not drain in 96 hours)	<input type="checkbox"/> Included <input type="checkbox"/> Not required because BMPs will drain in less than 96 hours



# Hydromodification Exemption Exhibit

St John the Baptizer Ukrainian Catholic Church

## Legend

-  Hydromod Exemptions
-  San Diego River Floodplain
-  San Diego River Floodway

Project Location

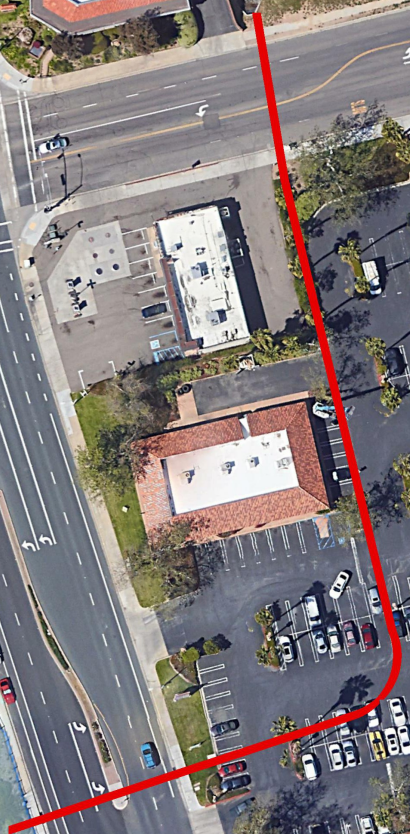

300 ft



***Use this checklist to ensure the required information has been included on the Hydromodification Management Exhibit:***

The Hydromodification Management Exhibit must identify:

- Underlying hydrologic soil group
- Approximate depth to groundwater
- Existing natural hydrologic features ( watercourses, seeps, springs, wetlands)
- Critical coarse sediment yield areas to be protected
- Existing topography
- Existing and proposed site drainage network and connections to drainage offsite
- Proposed grading
- Proposed impervious features
- Proposed design features and surface treatments used to minimize imperviousness
- Point(s) of Compliance (POC) for Hydromodification Management
- Existing and proposed drainage boundary and drainage area to each POC (when necessary, create separate exhibits for pre-development and post-project conditions)
- Structural BMPs for hydromodification management (identify location, type of BMP, and size/detail)

Attachment 2a  
**Hydromodification Management Exhibit**

Attachment 2b  
**Management of Critical Coarse Sediment Yield Areas**



Attachment 2c  
**Geomorphic Assessment of Receiving  
Channels (Optional)**

Attachment 2d  
**Flow Control Facility Design, including Structural BMP  
Drawdown Calculations and Overflow Design**

**ATTACHMENT 3**  
**Structural BMP Maintenance Information**

*This is the cover sheet for Attachment 3.*

**Indicate which Items are Included behind this cover sheet:**

<b>Attachment Sequence</b>	<b>Contents</b>	<b>Checklist</b>
Attachment 3a	Structural BMP Maintenance Thresholds and Actions (Required)	<input checked="" type="checkbox"/> Included  See Structural BMP Maintenance Information Checklist on the back of this Attachment cover sheet.
Attachment 3b	Draft Maintenance Agreement (when applicable)	<input type="checkbox"/> Included <input checked="" type="checkbox"/> Not Applicable

***Use this checklist to ensure the required information has been included in the Structural BMP Maintenance Information Attachment:***

**Preliminary Design / Planning / CEQA level submittal:**

Attachment 3a must identify:

- Typical maintenance indicators and actions for proposed structural BMP(s) based on Section 7.7 of the BMP Design Manual

Attachment 3b is not required for preliminary design / planning / CEQA level submittal.

**Final Design level submittal:**





Attachment 3a must identify:

- Specific maintenance indicators and actions for proposed structural BMP(s). This shall be based on Section 7.7 of the BMP Design Manual and enhanced to reflect actual proposed components of the structural BMP(s)
- How to access the structural BMP(s) to inspect and perform maintenance
- Features that are provided to facilitate inspection (e.g., observation ports, cleanouts, silt posts, or other features that allow the inspector to view necessary components of the structural BMP and compare to maintenance thresholds)
- Manufacturer and part number for proprietary parts of structural BMP(s) when applicable
- Maintenance thresholds specific to the structural BMP(s), with a location-specific frame of reference (e.g., level of accumulated materials that triggers removal of the materials, to be identified based on viewing marks on silt posts or measured with a survey rod with respect to a fixed benchmark within the BMP)
- Recommended equipment to perform maintenance
- When applicable, necessary special training or certification requirements for inspection and maintenance personnel such as confined space entry or hazardous waste management

Attachment 3b: For private entity operation and maintenance, Attachment 3b shall include a draft maintenance agreement in the local jurisdiction's standard format (PDP applicant to contact the [City Engineer] to obtain the current maintenance agreement forms).

EXHIBIT 3: BMP MAINTENANCE AGREEMENT EXHIBIT

**BMP LEGEND**

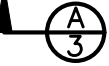
-  5,714 SF. LANDSCAPE WITH DROUGHT TOLERANT SPECIES (SITE DESIGN/LID 4.3.7)
-  BIOFILTRATION
-  BOUNDARY
-  STORMDRAIN FLOW
-  SURFACE FLOW
-  BMP IDENTIFICATION SHEET#

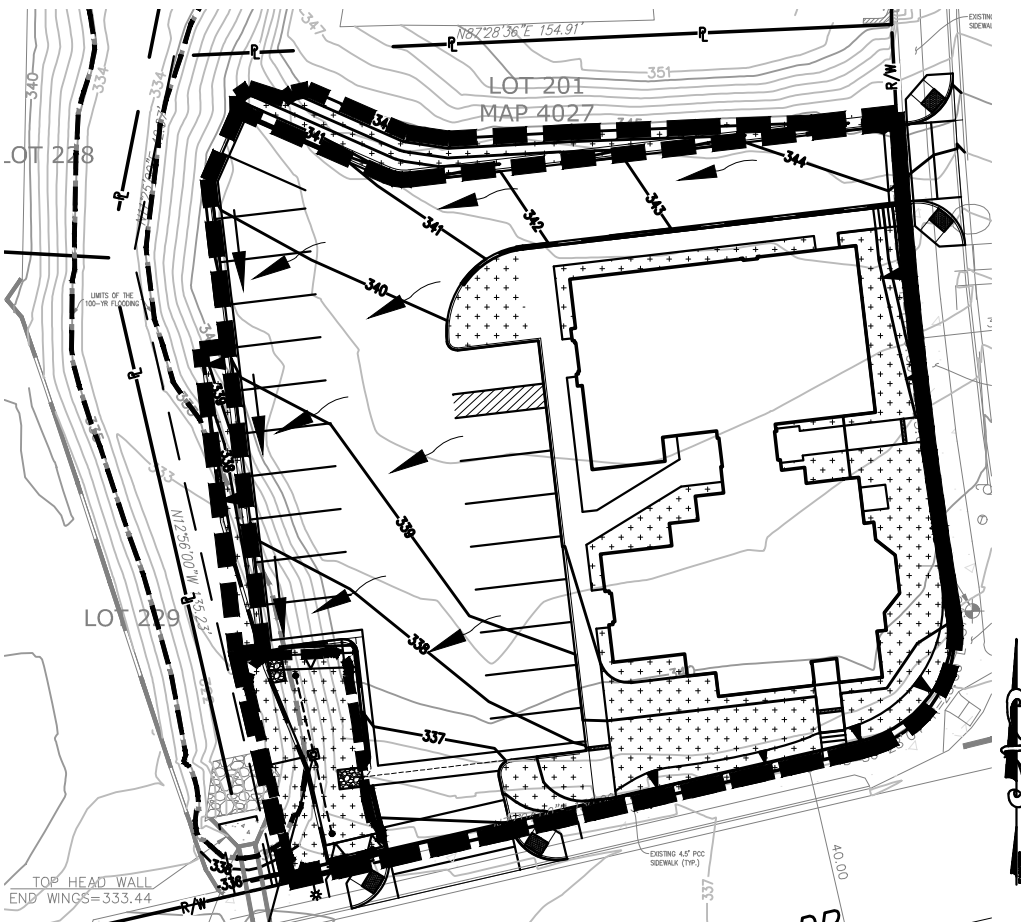
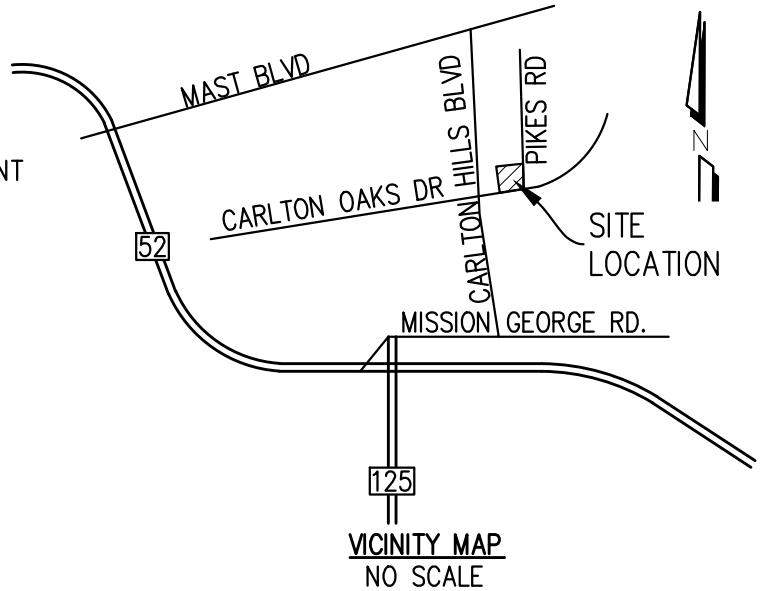

**DMA MAP**  
SCALE 1" : 40'

BF-A  
TREATMENT BMP  
SEE SHEET 2

THE ACCESS TO THE PROPOSED BMP  
WILL BE THROUGH THE PROPOSED  
DRIVEWAY AND PARKING LOT

**DCV REDUCTION NOTE**  
THIS PROJECT WILL NOT CLAIM DCV  
REDUCTION BMP'S

# BIOFILTRATION BF-A

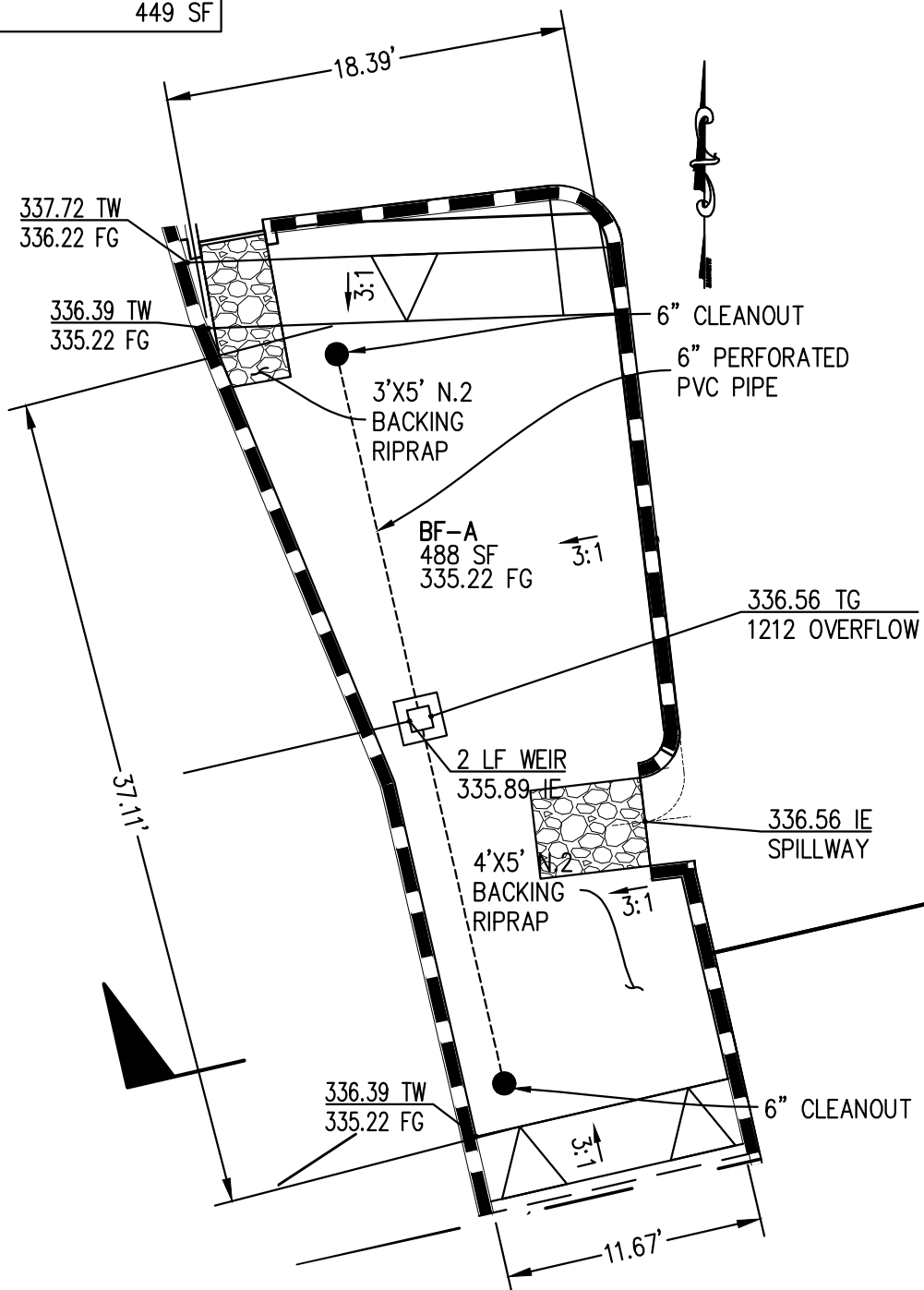

## EXHIBIT 3: BMP MAINTENANCE AGREEMENT EXHIBIT

BMP AREA SUMMARY	BF-A
GROSS AREA PROVIDED	472 SF
1212 PRECAST OVERFLOW BOX	4 SF
NET AREA PROVIDED	468 SF
AREA REQUIRED	449 SF

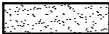

**BMP PLAN**  
SCALE: 1:8

**BMP LEGEND**

-  MEDIA LAYER
-  FILTER COURSE
-  AGGREGATE STORAGE LAYER

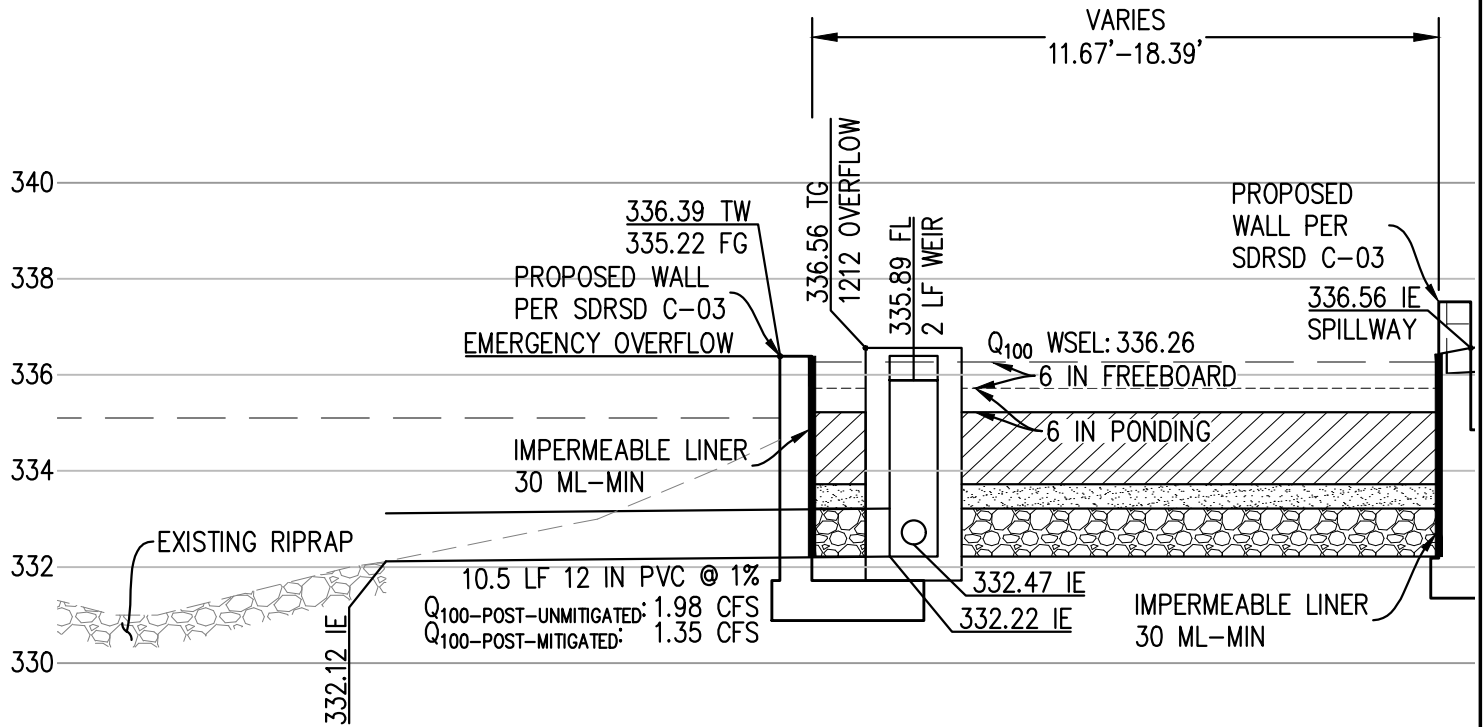

**BF-A CROSS SECTION** (A)  
SCALE 1:4



Chapter 7: Long Term Operation and Maintenance

TABLE 0-2. Maintenance Indicators and Actions for Vegetated BMPs

Typical Maintenance Indicator(s) for Vegetated BMPs	Maintenance Actions
Accumulation of sediment (sedimentation), litter, or debris	Remove and properly dispose of accumulated materials, without damage to the vegetation.
Poor vegetation establishment	Re-seed, re-plant, or re-establish vegetation per original plans, without the use of chemical applications.
Overgrown vegetation	Mow or trim as appropriate, but not less than the design height of the vegetation per original plans (e.g. a vegetated swale may require a minimum vegetation height).
Erosion due to concentrated irrigation flow	Repair/re-seed/re-plant eroded areas and adjust the irrigation system.
Erosion due to concentrated storm water runoff flow	Repair/re-seed/re-plant eroded areas, and make appropriate corrective measures such as retilling the soil, replacing or amending the soil media, adding erosion control BMPs, adding stone at flow entry points, or minor re-grading to restore proper drainage according to the original plan. <b>If the issue is not corrected by restoring the BMP to the original plan and grade, the City Engineer shall be contacted prior to any additional repairs or reconstruction. Any modifications to the existing approved SWQMP must be reviewed and approved by the City in advance.</b>
Standing water in vegetated swales	Take appropriate corrective measures such as adjusting irrigation system, removing obstructions of debris or invasive vegetation, loosening or replacing top soil to allow for better infiltration, or minor re-grading for proper drainage. If the issue is not corrected by restoring the BMP to the original plan and grade, the City Engineer shall be contacted prior to any additional repairs or reconstruction. Any modifications to the existing approved SWQMP must be reviewed and approved by the City in advance.
Standing water in bioretention, biofiltration with partial retention, or biofiltration areas, or flow-through planter boxes for longer than 96 hours following a storm event*	Make appropriate corrective measures such as adjusting irrigation system, removing obstructions of debris or invasive vegetation, clearing underdrains (where applicable), or repairing/replacing clogged or compacted soils.
Obstructed inlet or outlet structure	Clear obstructions and properly dispose of materials.
Damage to structural components such as weirs, inlet or outlet structures	Repair or replace as applicable.
*These BMPs typically include a surface ponding layer as part of their function which may take no longer than 96 hours to drain following a storm event.	

MAINTENANCE RECOMMENDATION AND FREQUENCY

THE POND FLOWLINE SHOULD BE INSPECTED SEMIANNUALLY BEFORE THE BEGINNING AND END OF THE WET SEASON AND AFTER EACH RAIN EVENT. THE INSPECTION OF THE BASIN SHOULD INCLUDE CHECKING FOR THE FOLLOWING PROBLEM ISSUES:

- STANDING WATER REMAINING 72 HOURS AFTER A RAIN EVENT.
- CHECK DISCHARGE PIPE AND ENSURE IS NOT CLOGGED OR BROKEN.
- SOIL EROSION OCCURRING IN OR AROUND BASIN, ESPECIALLY ALONG THE BASIN’S SLOPES AND PIPE OUTLET AT ITS ENERGY-DISSIPATING RIPRAP;
- ANIMAL BURROWS, FROM GOPHERS AND GROUND SQUIRRELS, IN AN AROUND THE BASIN, WHICH COULD NEGATIVELY AFFECT THE STRUCTURAL STABILITY OF BASINS SLOPES AND CAUSE SOIL EROSION;
- ACCUMULATED TRASH, DEBRIS AND SEDIMENT IN AND AROUND THE BASIN;
- AT THE BEGINNING AND END OF WEST SEASON TRIM VEGETATION AS WELL AS INSPECTED MONTHLY TO AVERT WOODY VEGETATION FOUNDATION, ALONG WITH AESTHETIC AND VECTOR REASONS;
- POND FLOWLINE SHOULD INSPECTED EVERY YEAR FOR ACCUMULATED SEDIMENT VOLUME. ACCUMULATED SEDIMENT MUST BE REMOVED, DISPOSED TO A LEGAL SITE AND CHANNEL RE-GRADED EVERY 10 YEARS OR WHEN THE ACCUMULATED SEDIMENT VOLUME EXCEEDS 10 PERCENT OF THE BASIN VOLUME.

IN ADDITION TO THE OPERATION AND MAINTENANCE, THE OWNER SHALL IMPLEMENT THE TASKS AS SHOWN IN THE FOLLOWING SHEET FOR THE PROPER MAINTENANCE AND EFFECTIVE FUNCTIONING OF THE BMP DEVICE.

<u>DESCRIPTION</u>	<u>TASK</u>
PLANT MATERIAL	<p>SUNLIGHT, MOISTURE AND SOIL REQUIREMENTS. CHECK PLANTS WEEKLY FOR SIGNS OF DISTRESS (WILTING, YELLOW/BROWN LEAVES, ETC.)</p> <p>WEED AS NECESSARY, AS PART OF REGULAR WEEKLY MAINTENANCE.</p> <p>CLEAN DEAD DEBRIS FROM PLANTS AFTER GROWING SEASON AND ADD TO YOUR COMPOST PILE, IF AVAILABLE.</p>
BERM	<p>THERE ARE NO BERMS TO BE PROTECTED IN THIS BIOFILTRATION BASIN</p>
PONDING AREA	<p>IF PONDING AREA BEGINS TO RETAIN WATER LONGER THAN 24 HOURS, THEN SOIL PORES MAY HAVE BECOME CLOGGED WITH PARTICULATE MATTER. IF THIS OCCURS, REMOVE ALL SEDIMENT AND FOREIGN DEBRIS FROM PONDING SURFACE.</p> <p>CHECK FOR THE ACCUMULATION OF SEDIMENT OR DEBRIS AND REMOVE IT. ANY SILTATION ACCUMULATED DURING WET SEASON SHALL BE REMOVED EVERY YEAR TO THE DESIGN ELEVATIONS SHOWN ON CONSTRUCTION DOCUMENTS.</p> <p>TRASH AND DEBRIS ACCUMULATED IN THE BIOFILTRATION BASIN AREA AND AROUND THE INLET OR OUTLET, SHALL BE REMOVED DURING WEEKLY LANDSCAPE MAINTENANCE AND INSPECTIONS.</p>
SOIL	<p>CHECK SOIL FOR ANY EROSION AND SIGNIFICANT SEDIMENTATION AFTER SIGNIFICANT STORM EVENTS AND REPLACE AND/OR REMOVE DISPLACED SOIL.</p> <p>WHEN REPLACING SOIL MATRIX, DO NOT OVER COMPACT. IF SOILS BECOME COMPACTED OR IF SEDIMENT CLOGS PORES, SOIL LAYER MAY NEED TO BE REPLACED.</p>
MULCH	<p>AFTER THE INITIAL MULCH LAYER HAS BEEN APPLIED, CHECK AFTER SIGNIFICANT STORM EVENTS TO ENSURE THAT RAINWATER HAS NOT WASHED OUT AREAS OF MULCH. REPLENISH MULCH AS NEEDED.</p> <p>ADD A NEW MULCH LAYER EVERY YEAR, EITHER IN THE FALL OR SPRING</p>

DESCRIPTION

TASK

UNDERDRAIN AND  
OVERFLOW/OUTFLOW  
SYSTEM

ONCE A YEAR, IN SEPTEMBER, FLUSH UNDERGROUND PIPE SYSTEM THOROUGHLY.  
IF PONDING AREA BEGINS TO RETAIN WATER LONGER THAN 72 HOURS, THEN CHECK THE UNDERDRAIN PIPES FOR CLOGGING AND STANDING WATER. ALSO CHECK THE OUTLET PIPE DEVICE FOR CLOGGING.  
IF THE SYSTEM IS CLOGGED, USE THE CLEANOUTS AT THE UPSTREAM END OF THE UNDERDRAIN PIPES TO FLUSH AND REMOVE ANY OBSTRUCTION.  
WHEN SERVICING THE UNDERDRAIN PIPE SYSTEM AND USING THE CLEANOUTS TO UNCLOG OR FLUSH THE SYSTEM, REINSTALL AND TIGHTEN THE CLEANOUT CAPS.  
THE CLEANOUTS AND UNDERDRAIN SYSTEM SHOULD BE INSPECTED, EVERY THREE MONTHS, AND BETWEEN SEPTEMBER AND MAY, SHOULD BE INSPECTED EVERY MONTH.

DRAIN FILTER

INSPECT AND CLEAN ON A WEEKLY BASIS PRIMARILY FROM LARGE DEBRIS TO ENSURE AND MAINTAIN GRATE CAPACITY.  
REPLACE FILTER INSERT BEFORE THE RAINY SEASON, IN SEPTEMBER. INSPECT INSERT EVERY MONTH FOR EXCESSIVE ACCUMULATED GREASE AND DIRT AND REPLACE AS NEEDED. THIS IS IMPORTANT DURING DRY SEASON, ESPECIALLY DURING NON-SEASONAL STORM EVENTS.  
DURING THE DRY SEASON, INSPECT FILTER BEFORE AND AFTER ANY FORCASTED STORM EVENT. REPLACE AND/OR CLEAN AS NEEDED.

## **ATTACHMENT 4**

### **Copy of Plan Sheets Showing Permanent Storm Water BMPs**

This is the cover sheet for Attachment 4.

**Use this checklist to ensure the required information has been included on the plans:**

**The plans must identify:**

- Structural BMP(s) with ID numbers matching Form I-6 Summary of PDP Structural BMPs
- The grading and drainage design shown on the plans must be consistent with the delineation of DMAs shown on the DMA exhibit
- Details and specifications for construction of structural BMP(s)
- Signage indicating the location and boundary of structural BMP(s) as required by the [City Engineer]
- How to access the structural BMP(s) to inspect and perform maintenance
- Features that are provided to facilitate inspection (e.g., observation ports, cleanouts, silt posts, or other features that allow the inspector to view necessary components of the structural BMP and compare to maintenance thresholds)
- Manufacturer and part number for proprietary parts of structural BMP(s) when applicable
- Maintenance thresholds specific to the structural BMP(s), with a location-specific frame of reference (e.g., level of accumulated materials that triggers removal of the materials, to be identified based on viewing marks on silt posts or measured with a survey rod with respect to a fixed benchmark within the BMP)
- Recommended equipment to perform maintenance
- When applicable, necessary special training or certification requirements for inspection and maintenance personnel such as confined space entry or hazardous waste management
- Include landscaping plan sheets showing vegetation requirements for vegetated structural BMP(s)
- All BMPs must be fully dimensioned on the plans
- When proprietary BMPs are used, site-specific cross section with outflow, inflow, and model number shall be provided. Photocopies of general brochures are not acceptable.

