

TYPICAL SECTION OVER 5'-4"

ELEVATION HORIZONTAL REINF. NOT SHOWN

TYPICAL SECTION 5'-4" MAX

DIMENSIONS AND REINFORCING STEEL			
H (MAX)	3'-8"	5'-4"	8'-0"
T (MIN)	0'-11"	1'-0"	1'-4"
W (MIN)	2'-7"	3'-8"	5'-10"
(A) BARS	#4@32"	#4@16"	#5@24"
(B) BARS	—	#4@16"	#5@24"
(C) BARS	—	—	#6@16"
(E) BARS	#4 TOTAL 4	#4 TOTAL 5	#4 TOTAL 6
MAX SOIL PRESSURE	1500 PSF	2000 PSF	3000 PSF

- NOTES: 1. SEE C-7 AND C-8 FOR ADDITIONAL NOTES AND DETAILS.  
2. FILL ALL BLOCK CELLS WITH GROUT.

Revision	By	Approved	Date
ORIGINAL		Kercheval	12/75
Add Metric		T. Stanton	03/03
Delete Metric	S.S.	T. Shell	03/11
Reviewed	TS	T. Stanton	11/15
Reviewed	DH	T. Stanton	09/17

SAN DIEGO REGIONAL STANDARD DRAWING

MASONRY RETAINING WALL TYPE 1  
LEVEL BACKFILL WITH 10-IN HEEL

RECOMMENDED BY THE SAN DIEGO REGIONAL STANDARDS COMMITTEE

*T. Stanton* 10/25/2018  
Chairperson R.C.E. 19246 Date

DRAWING NUMBER C-01

**DESIGN CONDITIONS:**

Walls are to be used for the loading conditions shown for each type wall. Design H shall not be exceeded. Footing key is required except as shown otherwise or when found unnecessary by the Engineer. Special footing design is required where foundation material is incapable of supporting toe pressure listed in table.

**DESIGN DATA:**

**Reinforced Concrete:**

Fc=1200 psi      F'c=3000 psi  
Fs=20,000 psi      n=10

**Reinforced Masonry:**

F'm=600 psi      Fm=200 psi  
Fs=20,000 psi      n=50  
Earth=120 pcf and Equivalent Fluid  
Pressure=36 psf per foot of height

Walls shown for 1 1/2:1 unlimited sloping surcharge are designed in accordance with Rankline's formula for unlimited sloping surcharge with a  $\phi = 42'$ .

**REINFORCEMENT:**

Intermediate grade, hard grade, or rail steel deformation shall conform ASTM A615, A616, A617. Bars shall lap 40 diameters, where spliced, unless otherwise shown on the plans. Bends shall conform to the Manual of Standard Practice, A.C.1. Backing for hooks is four diameters. All bar embedments are clear distances to outside of bar. Spacing for parallel bars is center to center bars.

**MASONRY:**

All reinforced masonry retaining walls be constructed of regular or light weight standard units conforming to the "Standard Specifications for Public Works Construction."

**JOINTS:**

Vertical control joints shall be placed at 32' intervals maximum. Joints shall be designed to resist shear and other lateral forces while permitting longitudinal movement. Vertical expansion joints shall be placed at 96' intervals maximum.

**CONCRETE:**

Footing concrete shall be 560-C-3250, using Type B aggregate when placing conditions permit.

**BACKFILL:**

No backfill material shall be placed against masonry retaining walls until grout has reached design strength or until grout has cured for a minimum of 28 days. Compaction of backfill material by jetting or ponding with water will not be permitted. Each layer of backfill shall be moistened as directed by the Engineer and thoroughly tamped, rolled or otherwise compacted until the relative compacting is not less than 90%.

**FENCING:**

Safety fencing shall be installed at the top of the wall as required by the agency.

**INSPECTIONS:**

Call for inspections as follows:

- A. When the footing has been formed, with the steel tied securely in final position, and is ready for the concrete to be placed.
- B. Where cleanout holes are not provided:
  - (1) After the blocks have been laid up to a height of 4' or full height for walls up to 5', with steel in place but before the grout is poured, and.....
  - (2) After the first lift is properly grouted, the blocks have been laid up to the top of the wall with the steel tied securely in place but before the upper lift is grouted.

Where cleanout holes are provided:

After the blocks have been laid up to the top of the wall, with the steel tied securely in place, but before grouting.

- C. After grouting is complete and after rock or rubble wall drains are in place but before earth backfill is placed.
- D. Final inspection when all work has been completed.

**CONCRETE GROUT AND MORTAR MIXES:**

Concrete grout shall attain a minimum compressive strength of 2,000 psi in 28 days and mortar shall attain 1,800 psi in 28 days.

All cells shall be filled with grout. Rod or vibrate consolidation. Bring grout within 10 minutes of pouring to insure grout to a point 2" from the top of masonry units when grouting of second lift is to be continued at another time.

**MORTAR KEY:**

To insure proper bonding between the footing and the first course of block, a mortar key shall be formed by embedding a flat 2 x 4 flush with and at the top of the freshly poured footing. The 2 x 4 should be removed after the concrete has started to harden (approximately 1 hour).

A mortar key may be omitted if the first course of block is set into the fresh concrete when the footing is poured, and a good bond is obtained.

**WALL DRAINS:**

Wall drains shall be provided in accordance with Standard Drawing C-8.

**SOIL:**

All footings shall extend at least 12" into undisturbed natural soil or approved compacted fill. Soil should be dampened prior to placing concrete in footings.

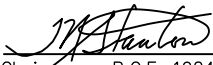
Revision	By	Approved	Date	SAN DIEGO REGIONAL STANDARD DRAWING  <b>GENERAL NOTES FOR MASONRY RETAINING WALLS</b>	RECOMMENDED BY THE SAN DIEGO REGIONAL STANDARDS COMMITTEE   10/25/2018 Chairperson R.C.E. 19246 Date
ORIGINAL		A. Kercheval	12/75		
Add Metric		T. Stanton	03/03		
Delete Metric	S.S.	T. Shell	03/11		
Reviewed	GT	T. Stanton	09/15		
				DRAWING NUMBER	C-07

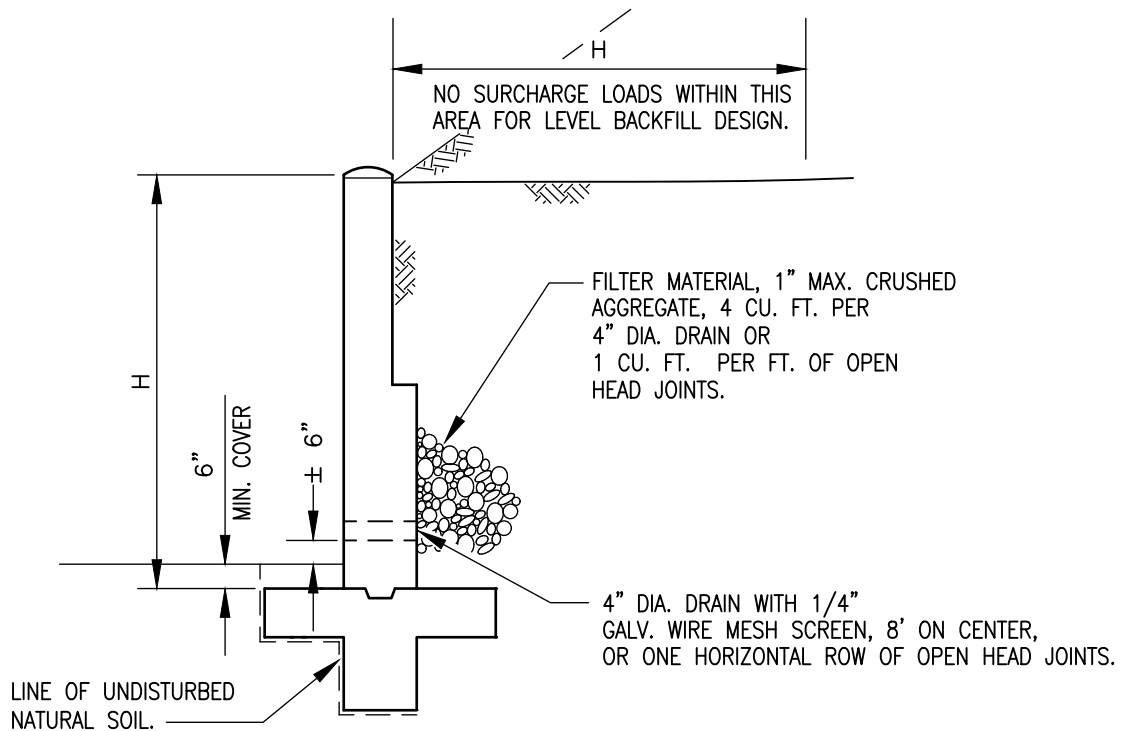

TYPICAL SECTION

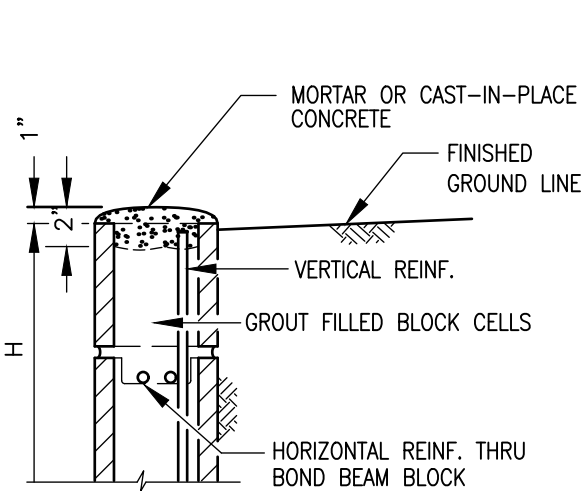

CAP DETAIL

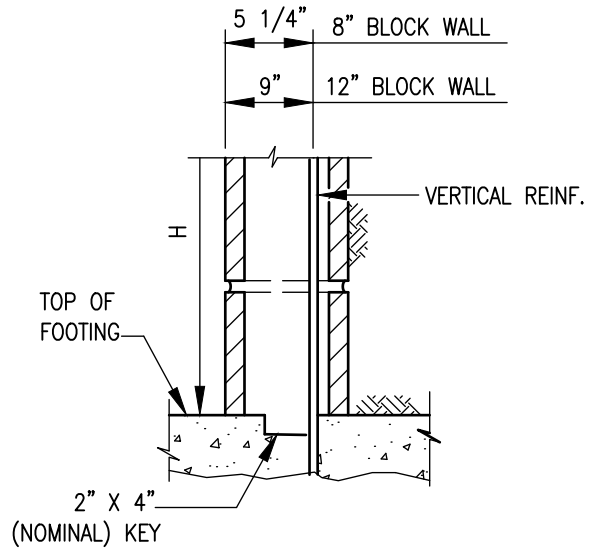

KEY DETAIL

NOTES:

1. ALL MASONRY RETAINING WALLS SHALL BE CONSTRUCTED WITH CAP, KEY AND DRAINAGE DETAILS AS SHOWN HEREON.
2. 4" DIAMETER DRAIN MAY BE FORMED BY PLACING A BLOCK ON IT'S SIDE.

Revision	By	Approved	Date
ORIGINAL		Kercheval	12/75
Add Metric		T. Stanton	03/03
Delete Metric	S.S.	T. Shell	03/11
Reviewed	TS	T. Stanton	11/15

SAN DIEGO REGIONAL STANDARD DRAWING

DETAILS FOR MASONRY RETAINING WALL

RECOMMENDED BY THE SAN DIEGO REGIONAL STANDARDS COMMITTEE

*T. Stanton* 10/25/2018  
Chairperson R.C.E. 19246 Date

DRAWING NUMBER C-08