

AMENDED PUBLIC WORKS STANDARDS, STREET DESIGN CRITERIA,  
SECTION 14, DRIVEWAYS

January, 2004

14. DRIVEWAYS

	Maximum*	Minimum*	Thickness
Commercial	52 feet	30 feet	5-1/2" or 9" PCC**
Residential	30 feet	12 feet	5-1/2" PCC
Maximum Frontage	Residential – 40%		
	Commercial & Industrial – 30 %		

\*Clear width measured at bottom of transition.

\*\*The 5-1/2 inch thick commercial driveway must be steel reinforced.

- A. Minimum clear distance between driveways on same property – two feet.
- B. Minimum clear distance from property line – three feet, unless joint driveway over property line is used.
- C. Minimum distance from curb return – 0 feet – no encroachment.
- D. Minimum distance from fire hydrant, utility or street light pole – three feet.

All dimensions are to top of transition unless otherwise noted.

- E. Alley Apron (PW-21) shall be use when the following conditions:
  - 1. When the development is commercial, industrial, or multiple residential and fronts on a Circulation Element Street.
  - 2. When the development is commercial, industrial, or multiple residential and fronts on any street having a current or projected Average Daily Traffic volume of 5,000 or greater.

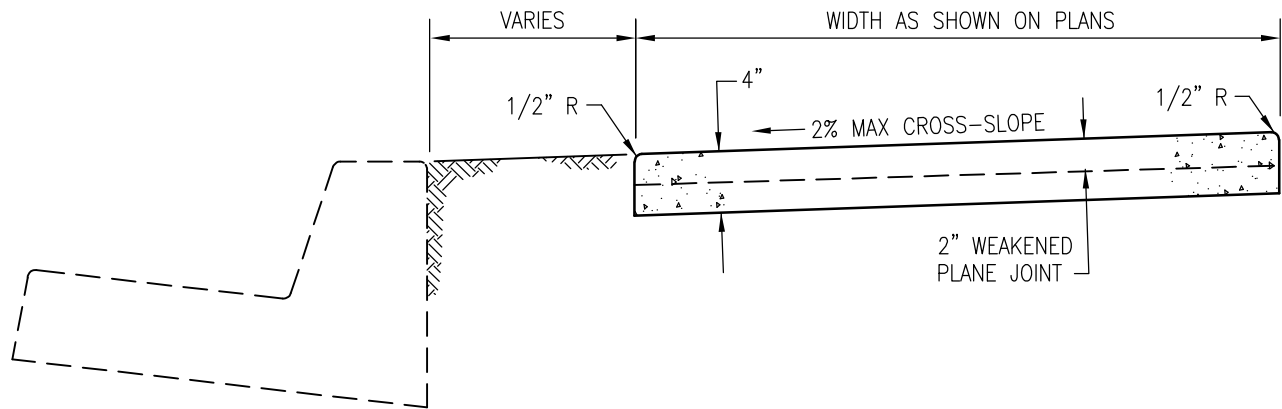

NON-CONTIGUOUS

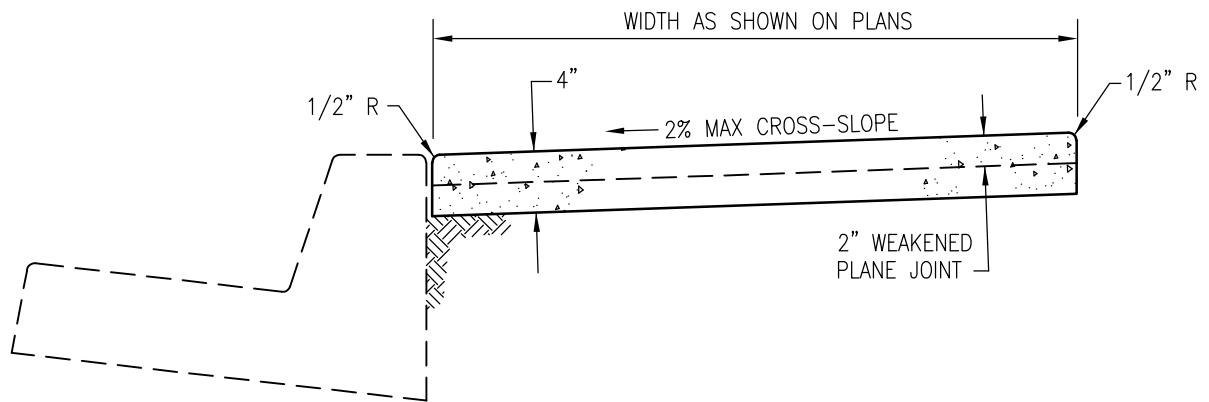

CONTIGUOUS

**NOTES:**

1. CONCRETE SHALL BE 520-C-2500.
2. SEE STANDARD DRAWINGS G-9 AND G-10 FOR JOINT DETAILS.

LEGEND ON PLANS

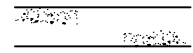

Revision	By	Approved	Date
ORIGINAL		KERCHEVAL	12/75
REVIEWED	CV	CV	12/15
Reviewed	KE	S. Stanton	10/18
Reviewed	RP	S. Engeda	03/22

SAN DIEGO REGIONAL STANDARD DRAWING

**SIDEWALK - TYPICAL SECTIONS**

RECOMMENDED BY THE SAN DIEGO REGIONAL STANDARDS COMMITTEE

*Samantha Engeda* 03/24/2022  
Chairperson R.C.E. 52241 Date

DRAWING NUMBER **G-07**

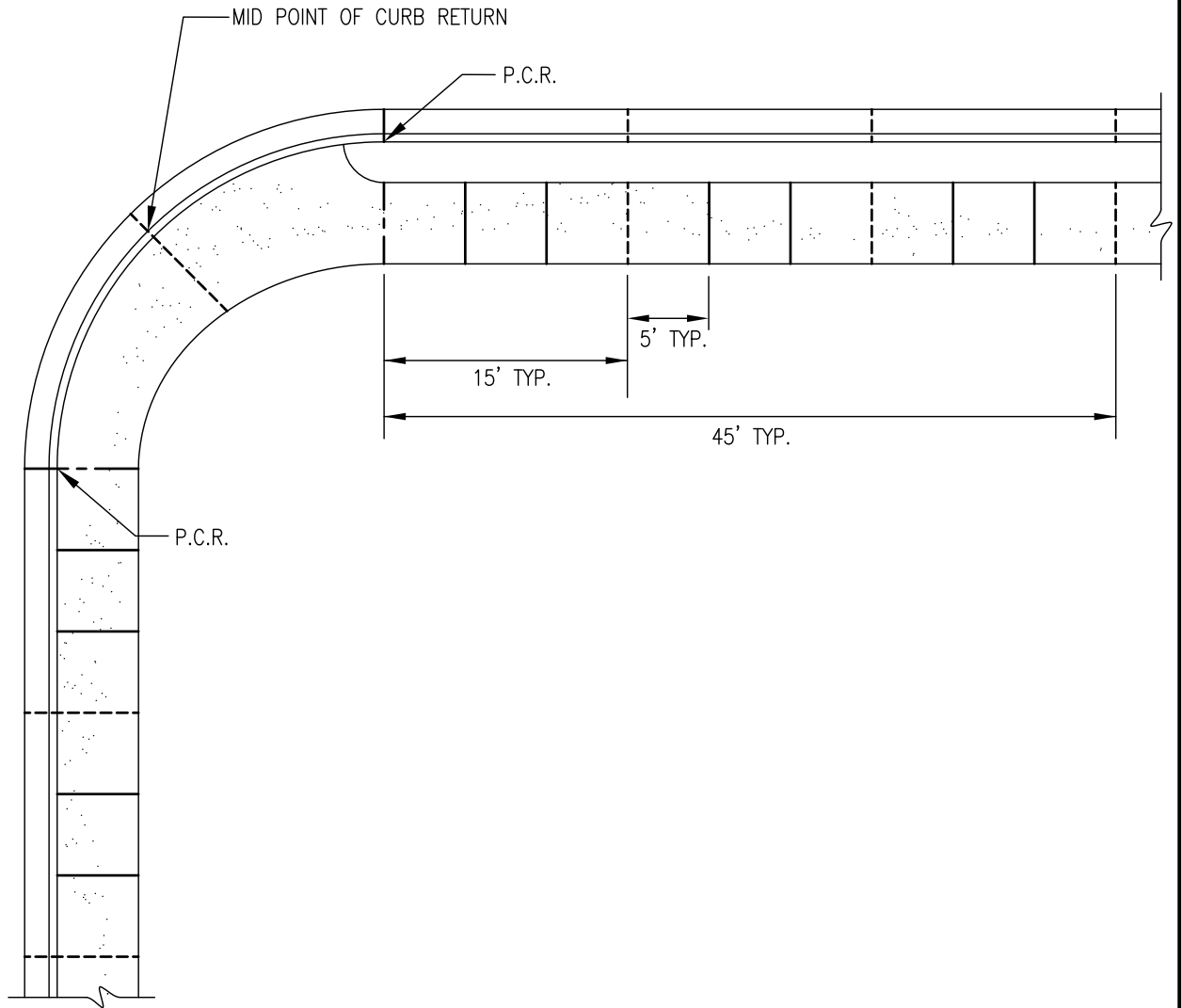

**NOTES:**

1. EXPANSION JOINTS AT CURB RETURNS, ADJACENT TO STRUCTURES AND AT 45' INTERVALS. (SEE STANDARD DRAWING G-10).
2. WEAKENED PLANE JOINTS AT MID POINT OF CURB RETURN, WHEN REQUIRED, AND AT 15' INTERVALS FROM P.C.R. (SEE STANDARD DRAWING G-10).
3. 1/4" GROOVES WITH 1/4" RADIUS EDGES AT 5' INTERVALS.

Revision	By	Approved	Date
ORIGINAL		KERCHEVAL	12/75
REFORMATTED		T. STANTON	04/06
REVIEWED	CV	CV	12/15
REVIEWED	RP	S. Engeda	03/22

SAN DIEGO REGIONAL STANDARD DRAWING

---

**SIDEWALK JOINT LOCATIONS**

RECOMMENDED BY THE SAN DIEGO REGIONAL STANDARDS COMMITTEE

*Samantha Engeda* 03/24/2022

Chairperson R.C.E. 52241 Date

**DRAWING NUMBER G-09**

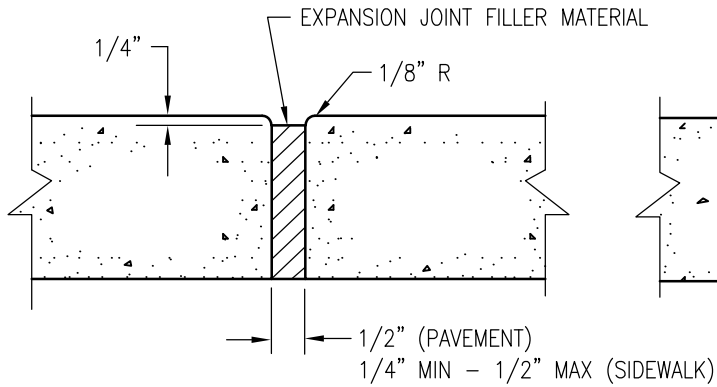

EXPANSION JOINT

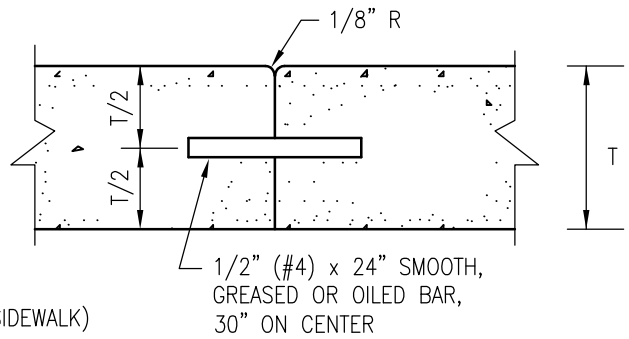

CONTACT JOINT

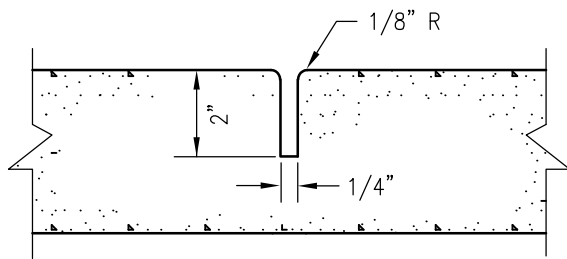

WEAKENED PLANE JOINT  
CURB AND SIDEWALK

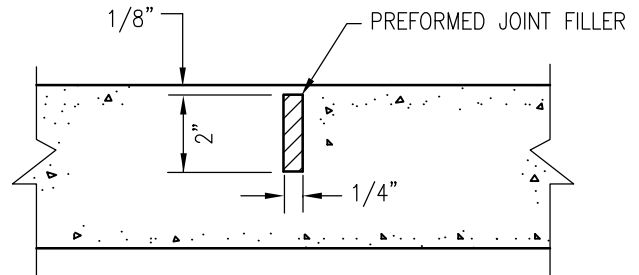

WEAKENED PLANE JOINT  
GUTTER AND CONCRETE PAVEMENT

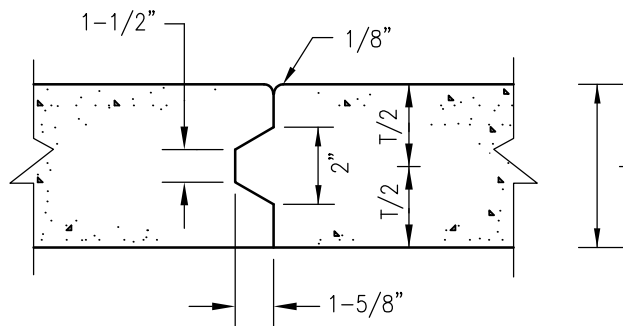

KEYED JOINT

Revision	By	Approved	Date
ORIGINAL		PARKINSON	02/95
UPDATED	CV	MR/CV	11/11
REVIEWED	CV	CV	12/15
Reviewed	RP	S. Engeda	03/22

SAN DIEGO REGIONAL STANDARD DRAWING

**CONCRETE JOINT DETAILS**

RECOMMENDED BY THE SAN DIEGO REGIONAL STANDARDS COMMITTEE

*Susan Engeda* 03/24/2022  
Chairperson R.C.E. 52241 Date

DRAWING NUMBER **G-10**

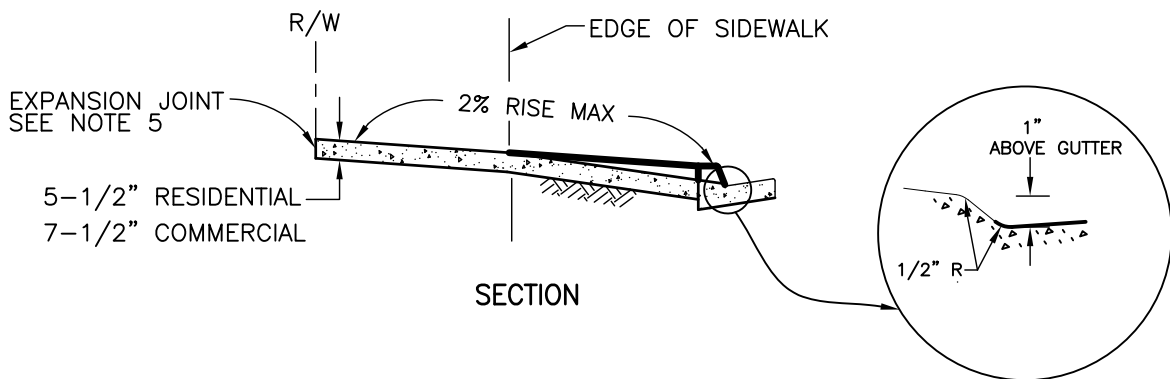
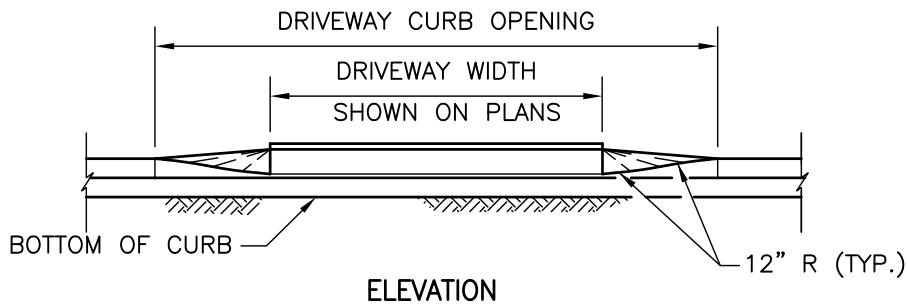
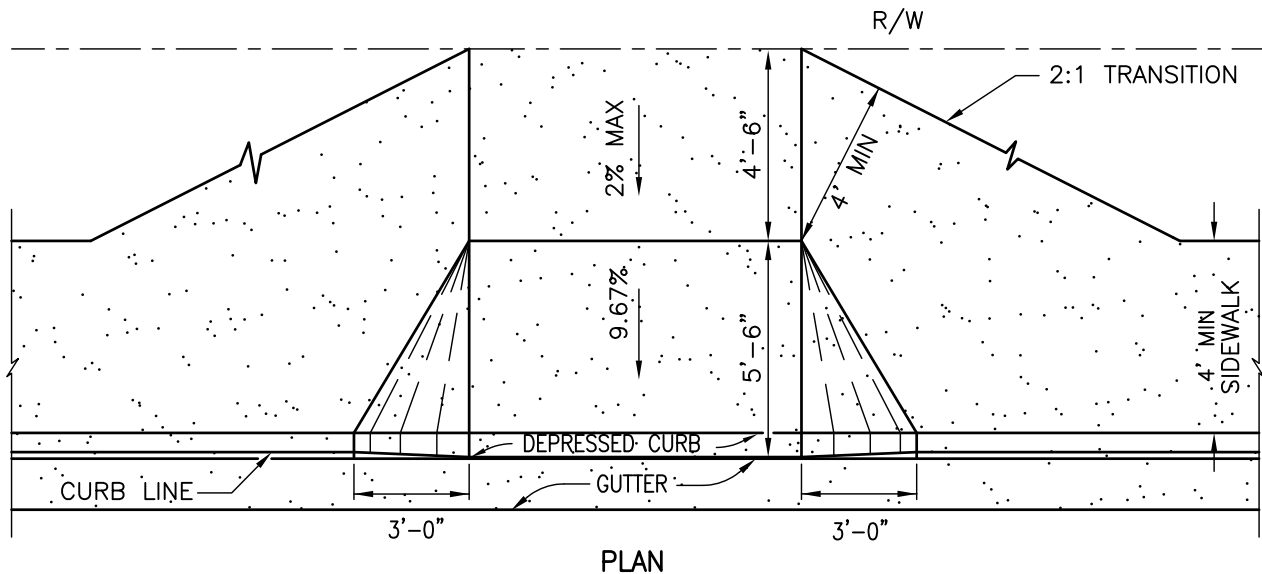

**NOTES:**

1. NO CONCRETE SHALL BE PLACED UNTIL FORMS AND SUBGRADE ARE INSPECTED BY THE AGENCY.
2. FOR RESIDENTIAL USE, CONCRETE SHALL BE 520-C-2500; FOR COMMERCIAL USE, CONCRETE SHALL BE 560-C-3250.
3. SEE STANDARD DRAWINGS G-15 AND G-16 FOR WIDTH AND LOCATION REQUIREMENTS.
4. DRIVEWAY RAMP TO EXTEND 10' FROM CURB FACE OR TO PROPERTY LINE WHICHEVER IS LESS.
5. PLACE EXPANSION JOINT AT RIGHT-OF-WAY OR 10' WHICHEVER IS LESS.
6. SEE STANDARD DRAWINGS G-2 AND G-10 FOR CURB AND JOINT DETAILS.
7. DIMENSIONS SHOWN REFLECT A 6" CURB HEIGHT.

Revision	By	Approved	Date
ORIGINAL		R. MUNOZ	4/97
UPDATED	MR	MR/CV	02/12
UPDATED	CV	CV	12/15
Reviewed	RP	S. Engeda	03/22

SAN DIEGO REGIONAL STANDARD DRAWING

**CONCRETE DRIVEWAY - TYPE A  
(CONTIGUOUS SIDEWALK)**

RECOMMENDED BY THE SAN DIEGO REGIONAL STANDARDS COMMITTEE

*Samantha Engeda* 03/24/2022  
Chairperson R.C.E. 52241 Date

DRAWING NUMBER **G-14A**

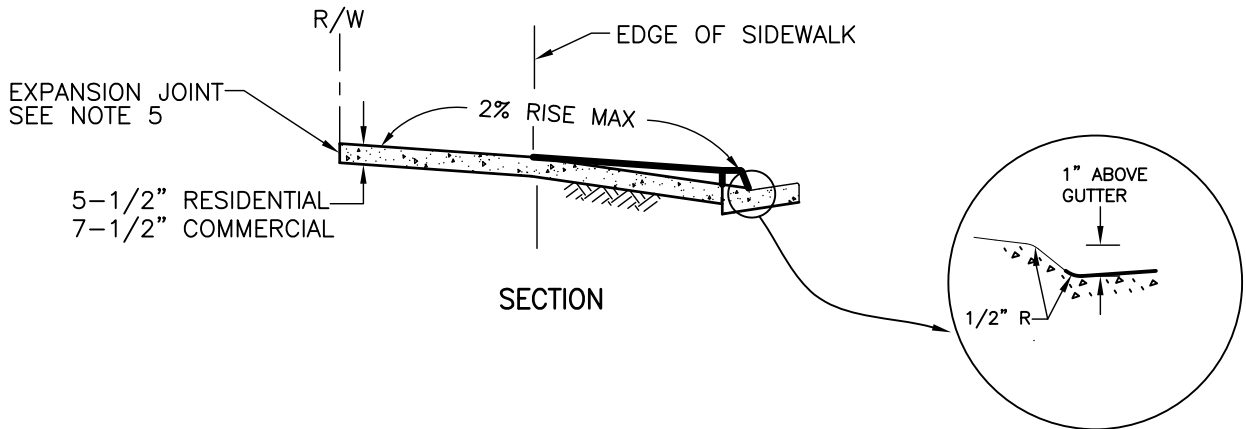
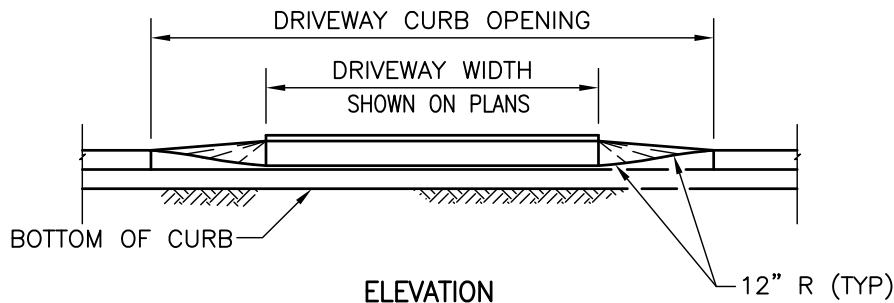
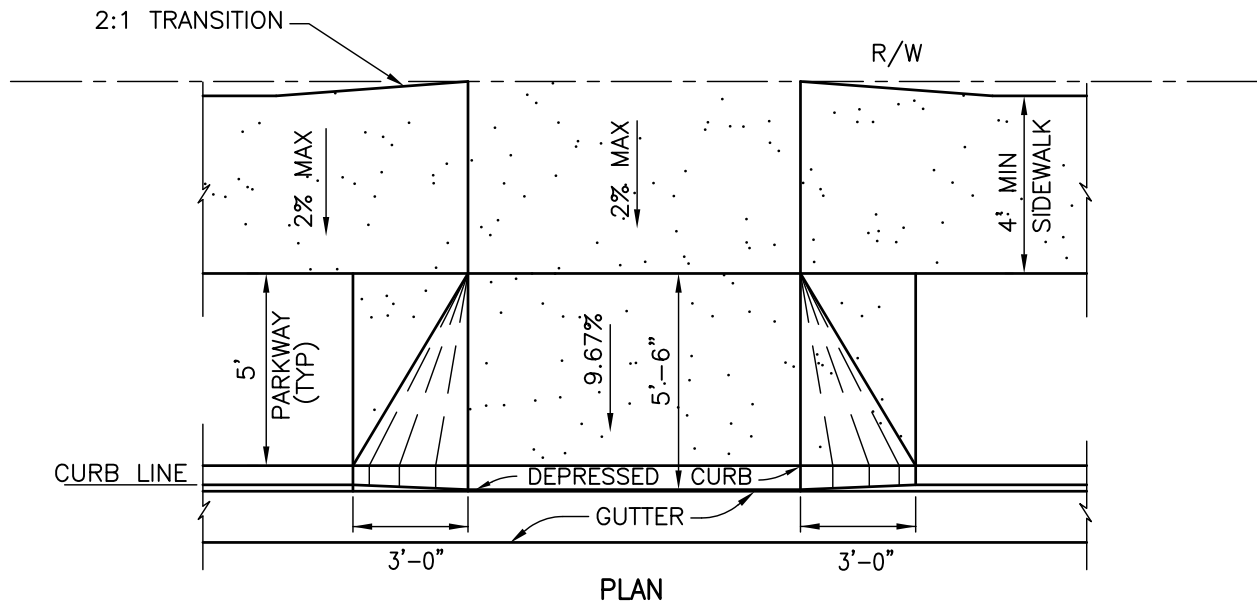

**NOTES:**

1. NO CONCRETE SHALL BE PLACED UNTIL FORMS AND SUBGRADE ARE INSPECTED BY THE AGENCY.
2. FOR RESIDENTIAL USE, CONCRETE SHALL BE 520-C-2500; FOR COMMERCIAL USE, CONCRETE SHALL BE 560-C-3250.
3. SEE STANDARD DRAWINGS G-15 AND G-16 FOR WIDTH AND LOCATION REQUIREMENTS.
4. DRIVEWAY RAMP TO EXTEND TO 10' FROM CURB FACE OR TO PROPERTY LINE WHICHEVER IS LESS.
5. PLACE EXPANSION JOINT AT RIGHT-OF-WAY OR 10', WHICHEVER IS LESS.
6. SEE STANDARD DRAWINGS G-2 AND G-10 FOR CURB AND JOINT DETAILS.
7. DIMENSIONS SHOWN REFLECT A 6" CURB HEIGHT.

Revision	By	Approved	Date
ORIGINAL		R. MUNOZ	4/97
UPDATED	MR	MR/CV	02/12
UPDATED	CV	CV	12/15
Reviewed	RP	S. Engeda	03/22

SAN DIEGO REGIONAL STANDARD DRAWING

**CONCRETE DRIVEWAY  
(NON-CONTIGUOUS SIDEWALK)**

RECOMMENDED BY THE SAN DIEGO REGIONAL STANDARDS COMMITTEE

*Samantha Engeda* 03/24/2022  
Chairperson R.C.E. 52241 Date

DRAWING NUMBER **G-14B**

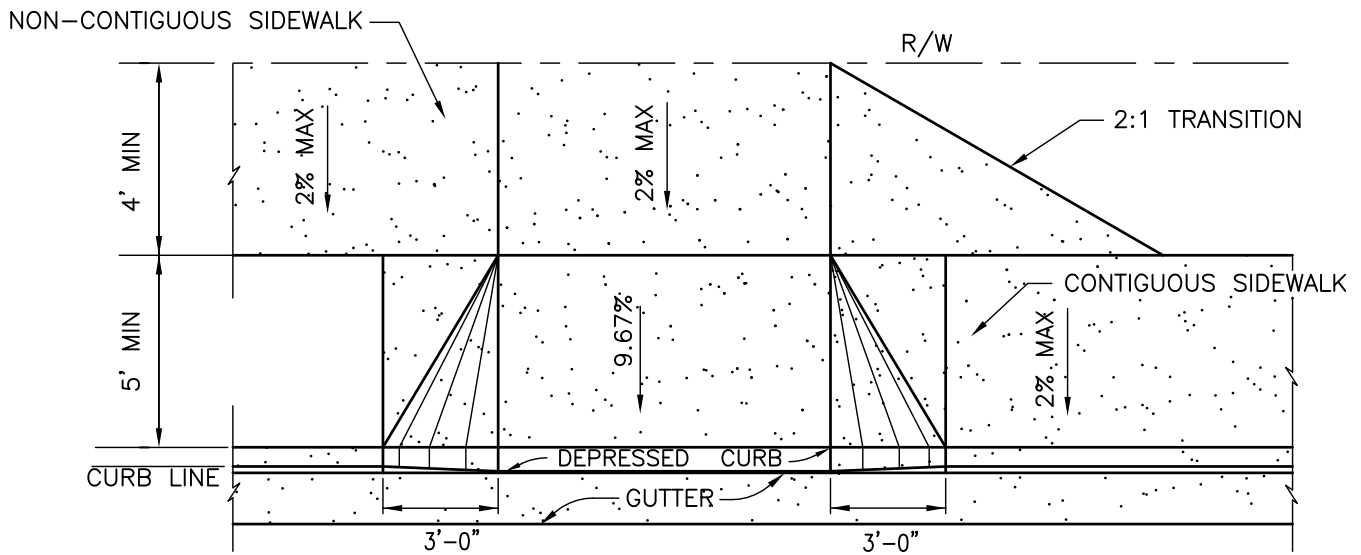

PLAN

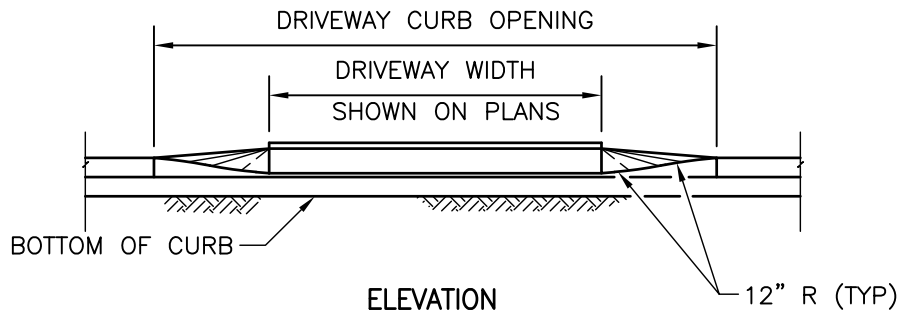

ELEVATION

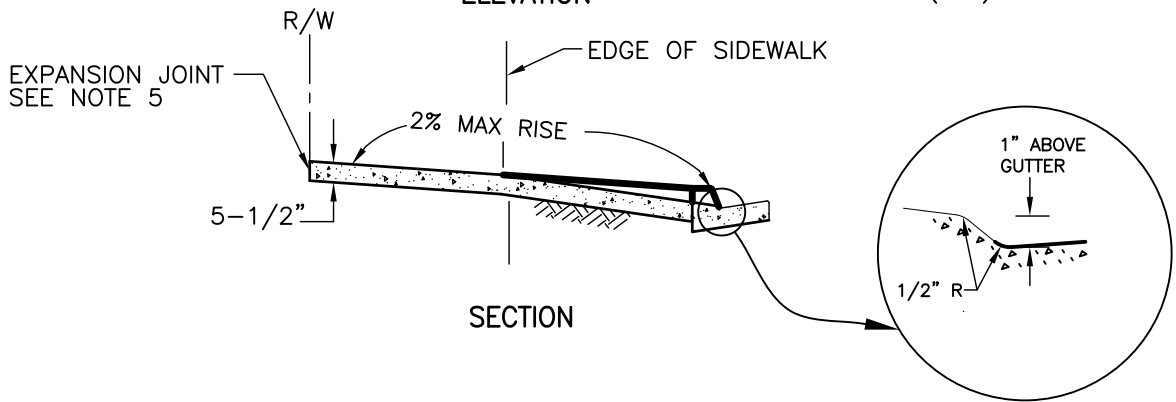

SECTION

NOTES:

1. NO CONCRETE SHALL BE PLACED UNTIL FORMS AND SUBGRADE ARE INSPECTED BY THE AGENCY.
2. CONCRETE SHALL BE 520-C-2500.
3. SEE STANDARD DRAWINGS G-15 AND G-16 FOR WIDTH AND LOCATION REQUIREMENTS.
4. DRIVEWAY RAMP TO EXTEND 10' FROM FACE OF CURB OR TO PROPERTY LINE WHICHEVER IS LESS.
5. PLACE EXPANSION JOINT AT RIGHT-OF-WAY OR 10', WHICHEVER IS LESS.
6. SEE STANDARD DRAWINGS G-2 AND G-10 FOR CURB AND JOINT DETAILS.
7. DIMENSIONS SHOWN REFLECT A 6" CURB HEIGHT.

Revision	By	Approved	Date
ORIGINAL		R. MUNOZ	4/97
UPDATED	MR	MR/CV	02/12
UPDATED	CV	CV	12/15
Reviewed	RP	S. Engeda	03/22

SAN DIEGO REGIONAL STANDARD DRAWING

---

**RESIDENTIAL  
CONCRETE DRIVEWAY  
(PARKWAY LESS THAN 10' IN DEPTH)**

RECOMMENDED BY THE SAN DIEGO REGIONAL STANDARDS COMMITTEE

*Somayr Engeda* 03/24/2022  
Chairperson R.C.E. 52241 Date

**DRAWING NUMBER G-14C**

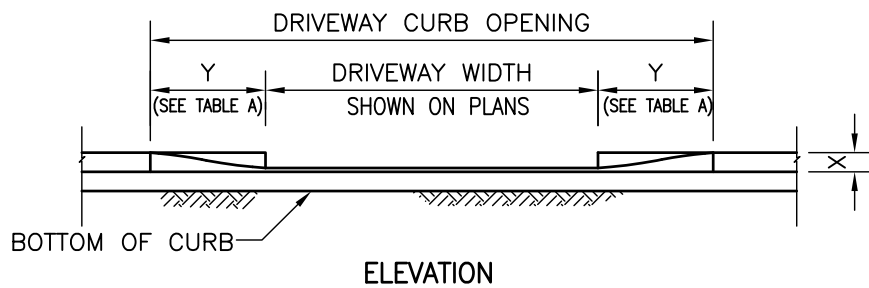
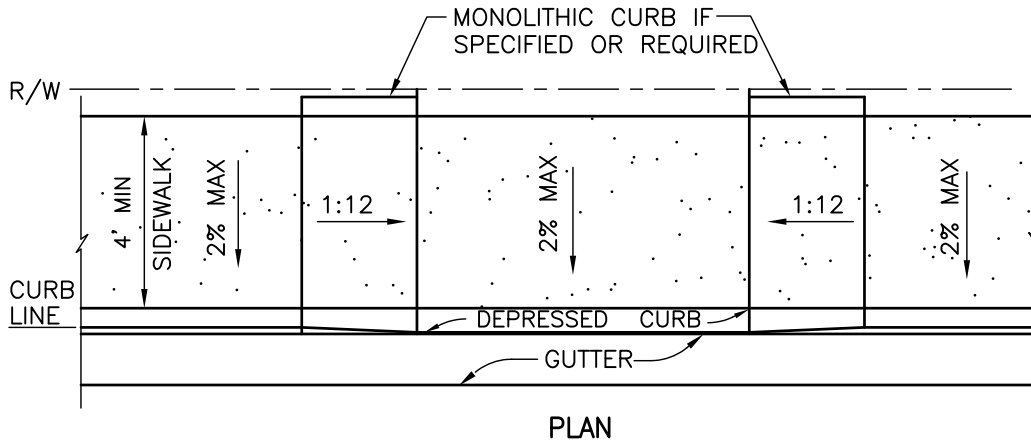
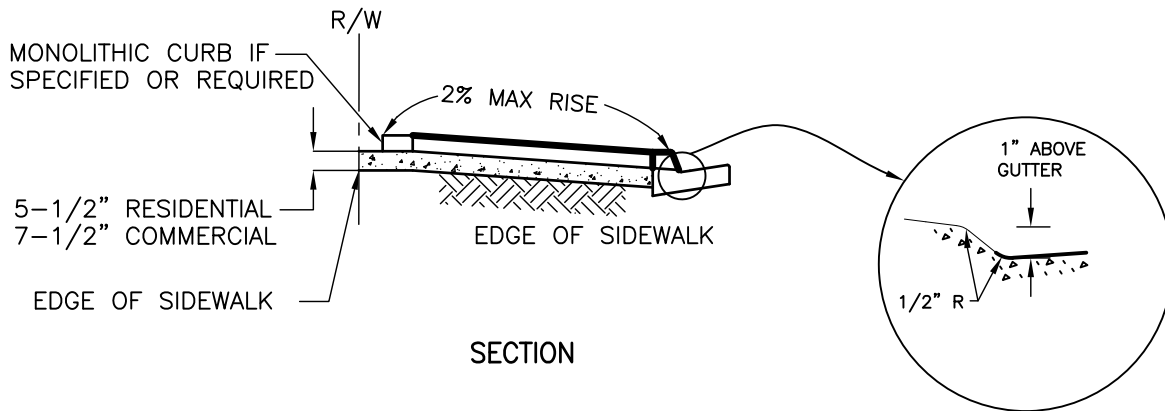

TABLE A	
X	Y
CURB HEIGHT	RAMP LENGTH
1"	0'-0"
2"	1'-0"
3"	2'-0"
4"	3'-0"
5"	4'-0"
6"	5'-0"
7"	6'-0"
8"	7'-0"



**NOTES:**

1. NO CONCRETE SHALL BE PLACED UNTIL FORMS AND SUBGRADE ARE INSPECTED BY THE AGENCY.
2. FOR RESIDENTIAL USE, CONCRETE SHALL BE 520-C-2500; FOR COMMERCIAL USE, CONCRETE SHALL BE 560-C-3250.
3. SEE STANDARD DRAWINGS G-15 AND G-16 FOR WIDTH AND LOCATION REQUIREMENTS.
4. SEE STANDARD DRAWINGS G-2 AND G-10 FOR CURB AND JOINT DETAILS.
5. PLACE EXPANSION JOINT AT RIGHT-OF-WAY.
6. DIMENSIONS SHOWN REFLECT A 6" CURB HEIGHT.
7. RAMP LENGTH CALCULATIONS ARE BASED ON X=1" TO ACCOUNT FOR THE 1" DRIVEWAY LIP.
8. IF USING FOR ALLEY CROSSING, INSTALL TRUNCATED DOMES PER G-30 AT BOTTOM OF RAMPS.

Revision	By	Approved	Date
Reviewed		T. STANTON	04/06
Updated	MR	MR/CV	02/12
Updated	CV	CV	12/15
Updated	RP	S. Engeda	03/22

SAN DIEGO REGIONAL STANDARD DRAWING

**CONCRETE DRIVEWAY  
(FOR CONFINED RIGHT-OF-WAY)**

RECOMMENDED BY THE SAN DIEGO REGIONAL STANDARDS COMMITTEE

*Samantha Engeda* 03/24/2022  
Chairperson R.C.E. 52241 Date

DRAWING NUMBER **G-14D**



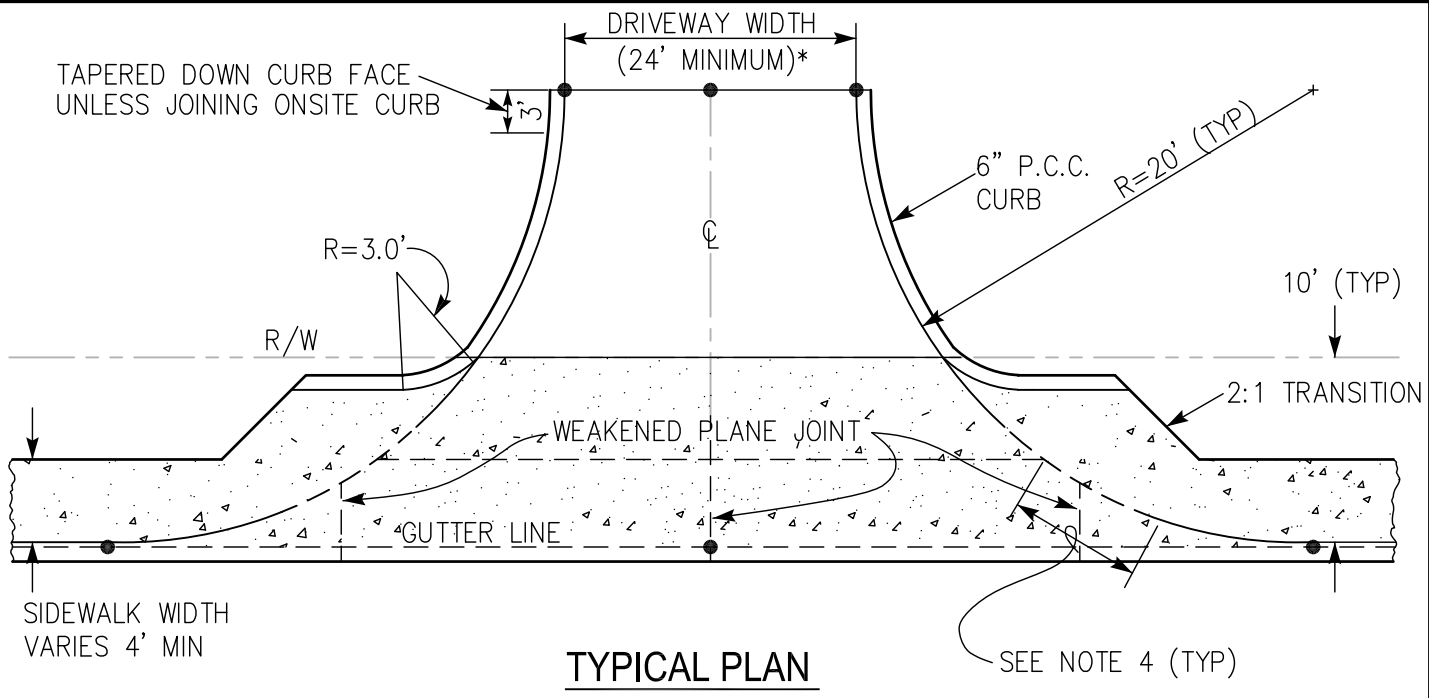

**TYPICAL PLAN**

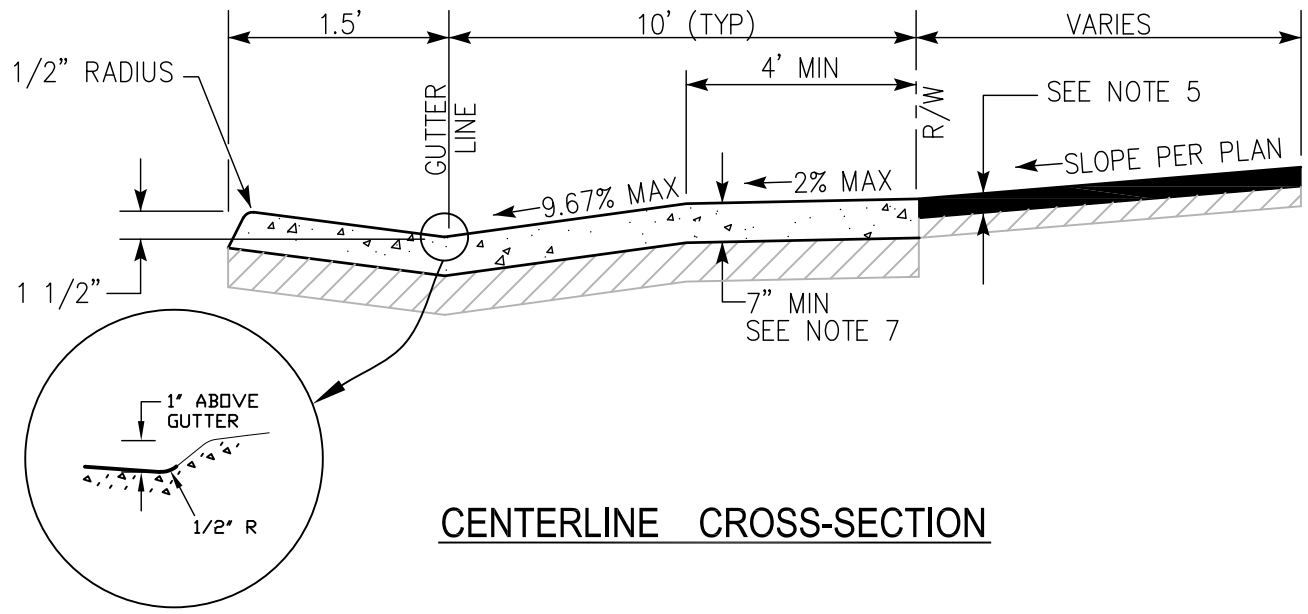

**CENTERLINE CROSS-SECTION**

1. \* OR AS REQUIRED BY THE AGENCY.
2. ● = ELEVATION SHOWN ON PLANS (TOP OF CURB, AND GUTTER ELEVATION)
3. ALL CONCRETE SHALL BE 560-C-3250
4. TRANSITION FROM FULL HEIGHT CURB TO NO CURB. 6FT TRANSITION FOR 5FT WIDE SIDEWALK AND 8FT TRANSITION FOR 6FT WIDE SIDEWALK.
5. PAVEMENT STRUCTURAL SECTION SHALL BE SHOWN ON PLANS.
6. SEE G-2 AND G-10 FOR CURB AND JOINT DETAILS.
7. BASE MATERIAL AS SHOWN ON PLANS.

Revision	By	Approved	Date	SAN DIEGO REGIONAL STANDARD DRAWING	RECOMMENDED BY THE SAN DIEGO REGIONAL STANDARDS COMMITTEE
NEW	MR	MR/CV	09/11		<b>CONCRETE DRIVEWAY (ALLEY TYPE)</b>
UPDATED	CV	CV	12/15	Chairperson R.C.E. 52241 Date	
Reviewed	RP	S. Engeda	03/22	DRAWING NUMBER <b>G-14E</b>	

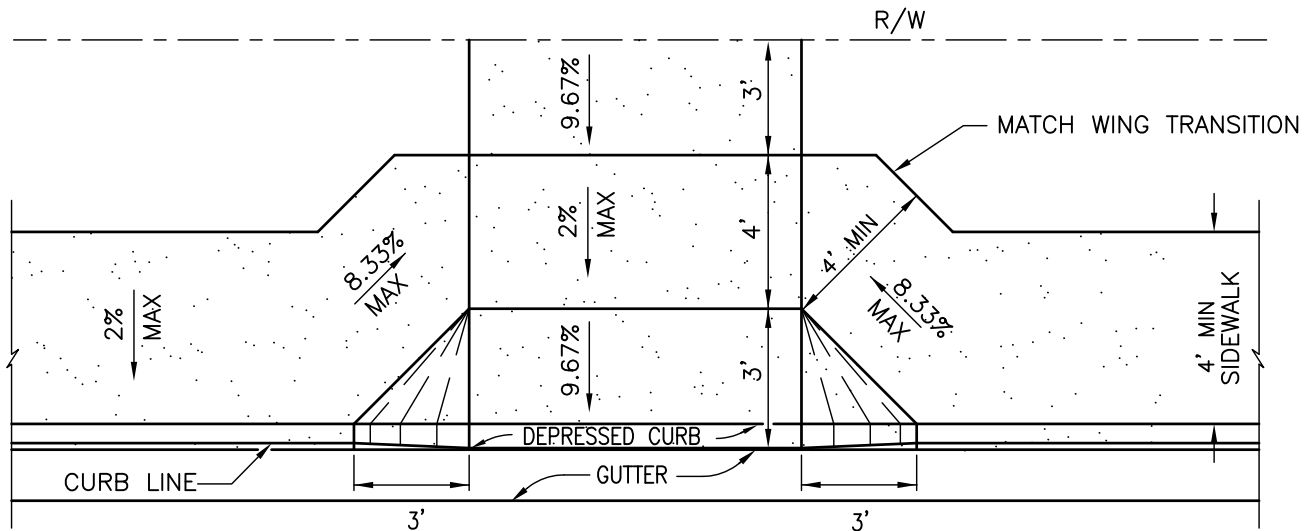

PLAN

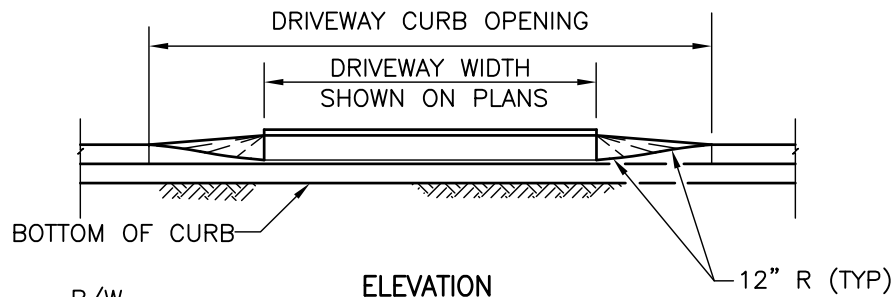

ELEVATION

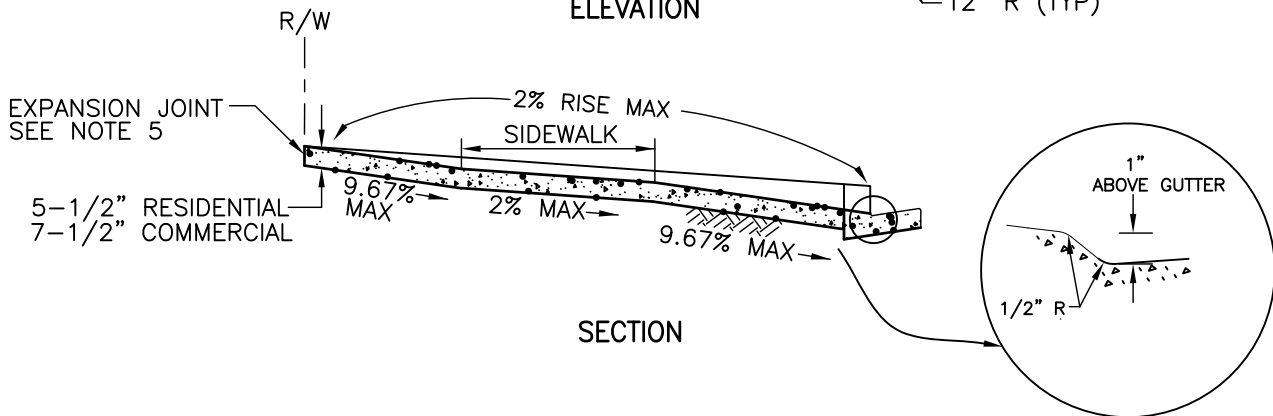

SECTION

NOTES:

1. NO CONCRETE SHALL BE PLACED UNTIL FORMS AND SUBGRADE ARE INSPECTED BY AGENCY.
2. FOR RESIDENTIAL USE, CONCRETE SHALL BE 520-C-2500; FOR COMMERCIAL USE, CONCRETE SHALL BE 560-C-3250.
3. SEE STANDARD DRAWINGS G-15 AND G-16 FOR WIDTH AND LOCATION REQUIREMENTS.
4. DRIVEWAY RAMP TO EXTEND TO 10' FROM CURB FACE OR TO RIGHT-OF-WAY, WHICHEVER IS LESS.
5. PLACE EXPANSION JOINT AT RIGHT-OF-WAY OR 10', WHICHEVER IS LESS.
6. SEE STANDARD DRAWINGS G-2 AND G-10 FOR CURB AND JOINT DETAILS.
7. DIMENSIONS SHOWN REFLECT A 6" CURB HEIGHT.

Revision	By	Approved	Date
NEW	MR	MR/CV	02/12
UPDATED	CV	CV	12/15
Reviewed	RP	S. Engeda	03/22

SAN DIEGO REGIONAL STANDARD DRAWING

**CONCRETE DRIVEWAY - TYPE B  
(CONTIGUOUS SIDEWALK)**

RECOMMENDED BY THE SAN DIEGO REGIONAL STANDARDS COMMITTEE

*Somayr Engeda* 03/24/2022  
Chairperson R.C.E. 52241 Date

DRAWING NUMBER **G-14F**

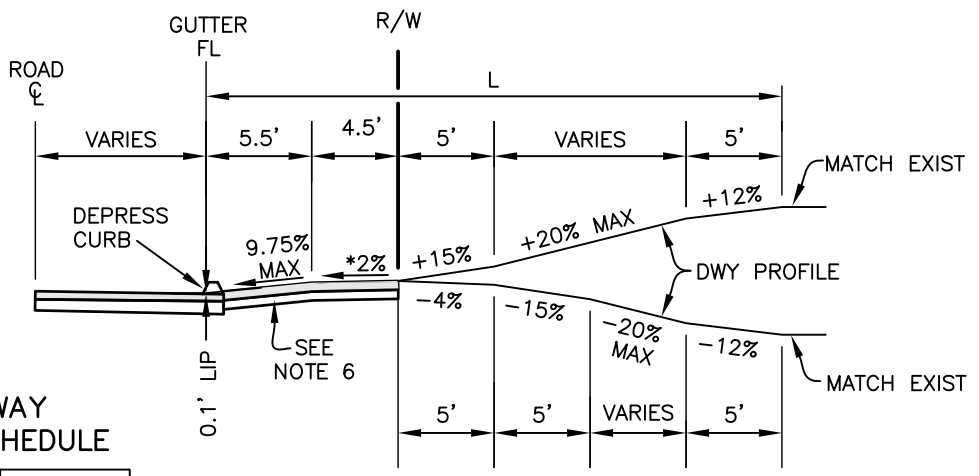
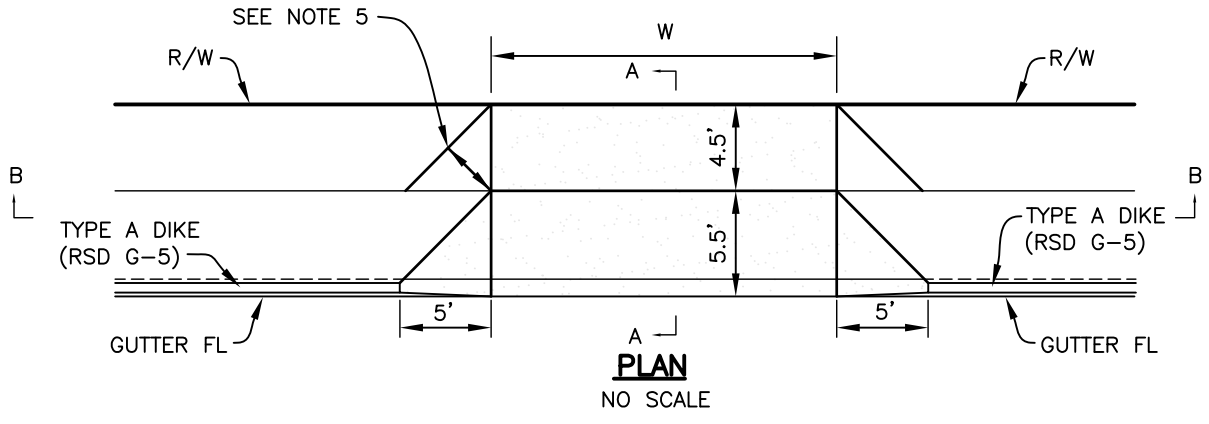

**DRIVEWAY PAVING SCHEDULE**

MINIMUM DEPTH OF A.C.	GRADE
2"	0-15%
3"	16-20%

MIN DEPTHS PER COUNTY FIRE STDS. LOCAL AGENCY REQUIREMENTS MAY VARY.

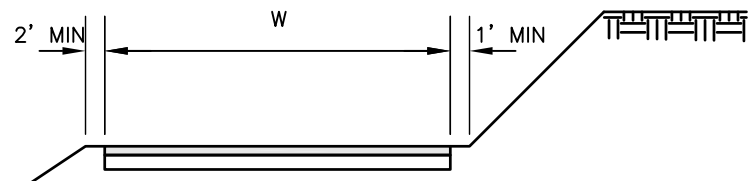

**NOTES:**

1. DRIVEWAY PROFILE, WIDTH (W) AND LENGTH (L) SHALL BE SHOWN ON PLANS.
2. DRIVEWAYS WITH GRADES GREATER THAN 15% SHALL BE SURFACED WITH ASPHALT CONCRETE (AC) OR PORTLAND CEMENT CONCRETE (PCC).
3. MAXIMUM GRADE BREAK 14% (5' MINIMUM VERTICAL CURVE PREFERRED).
4. SEE SAN DIEGO AREA REGIONAL STANDARD DRAWINGS G-15 & G-16 FOR DRIVEWAY LOCATION & WIDTH REQUIREMENTS AND G-14 SERIES FOR PCC DRIVEWAYS.
5. 4' MINIMUM ADA ACCESS WHEN WALKWAYS ARE PROVIDED.
6. 4" MINIMUM AC OVER 6" MINIMUM BASE, UNLESS OTHERWISE INDICATED ON PLANS.

Revision	By	Approved	Date	SAN DIEGO REGIONAL STANDARD DRAWING	RECOMMENDED BY THE SAN DIEGO REGIONAL STANDARDS COMMITTEE
NEW	MR	MR/CV	09/11		
UPDATED	CV	CV	12/15	<b>ASPHALT CONCRETE DRIVEWAY</b>	<i>Samantha Engeda</i> 03/24/2022
Reviewed	RP	S. Engeda	03/22		Chairperson R.C.E. 52241 Date
					DRAWING NUMBER <b>G-14G</b>

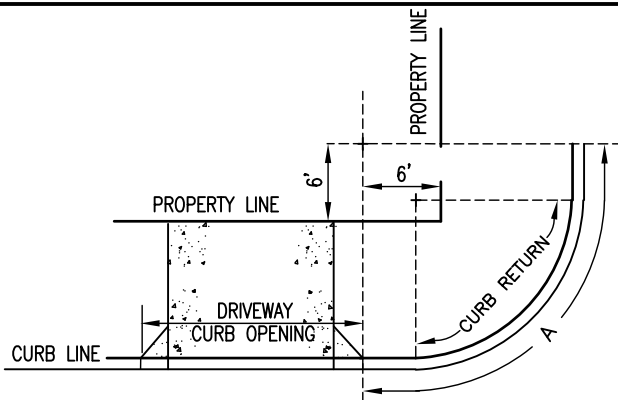

**REQUIREMENT 1**  
 NO PORTION OF ANY CURB OPENING SHALL BE PERMITTED WITHIN 6' OF THE INTERSECTION OF THE PROLONGED PROPERTY LINES AND THE CURB SHOWN BY ARC A.

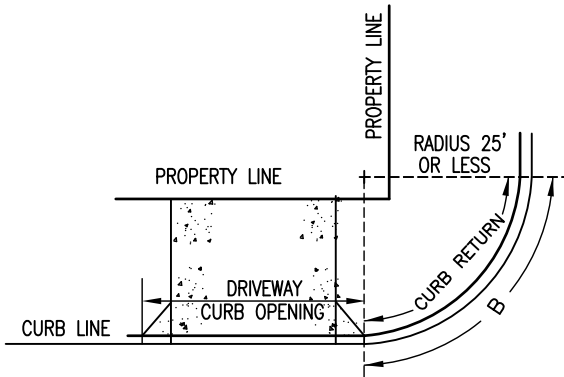

**REQUIREMENT 2**  
 NO PORTION OF ANY CURB OPENING SHALL BE PERMITTED IN THE CURB RETURN WHERE THE RADIUS OF CURB IS 25' OR LESS, AS SHOWN BY ARC B.

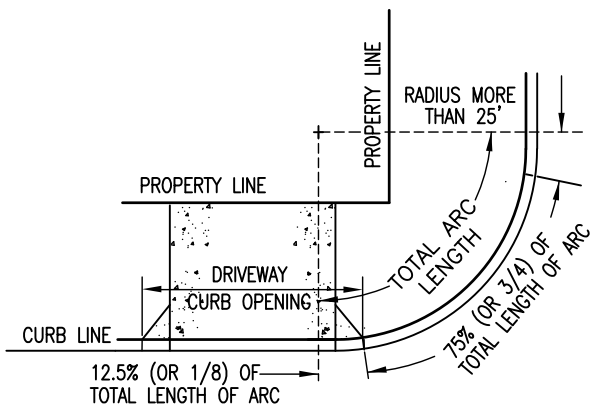

**REQUIREMENT 3**  
 ON ALL CURB RETURNS WHERE THE RADIUS IS MORE THAN 25', CURB OPENINGS MAY ENCROACH UPON EACH END OF THE RETURN A DISTANCE EQUAL TO 12.5% (OR 1/8) OF THE TOTAL LENGTH OF THE ARC ON THE CURB RETURN, THUS LEAVING AT LEAST 75% (OR 3/4) OF THE LENGTH OF ARC ON THE RETURN FACE FREE FROM DRIVEWAY ENCROACHMENT, PROVIDED REQUIREMENT 1 IS MET.

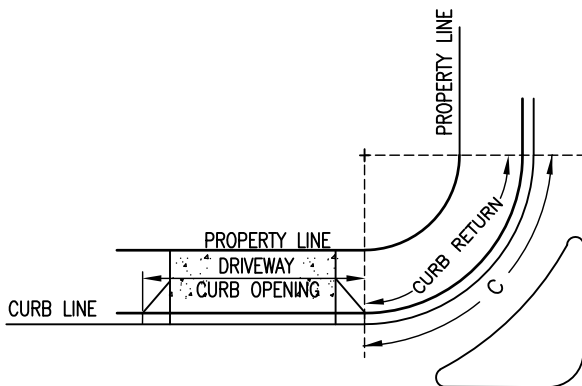

**REQUIREMENT 4**  
 NO PORTION OF ANY CURB OPENING SHALL BE PERMITTED IN THE CURB RETURN WHERE A SEPARATE TURNING MOVEMENT IS PROVIDED, AS SHOWN BY ARC C.

Revision	By	Approved	Date
ORIGINAL		KERCHEVAL	12/75
UPDATED	CV	CV	12/15
Reviewed	MW	M. Widelski	10/18
Reviewed	RP	S. Engeda	03/22

SAN DIEGO REGIONAL STANDARD DRAWING

**DRIVEWAY LOCATION - ADJACENT TO CURB RETURNS AND STREET LINES**

RECOMMENDED BY THE SAN DIEGO REGIONAL STANDARDS COMMITTEE

*Saman Engeda* 03/24/2022  
 Chairperson R.C.E. 52241 Date

DRAWING NUMBER **G-15**

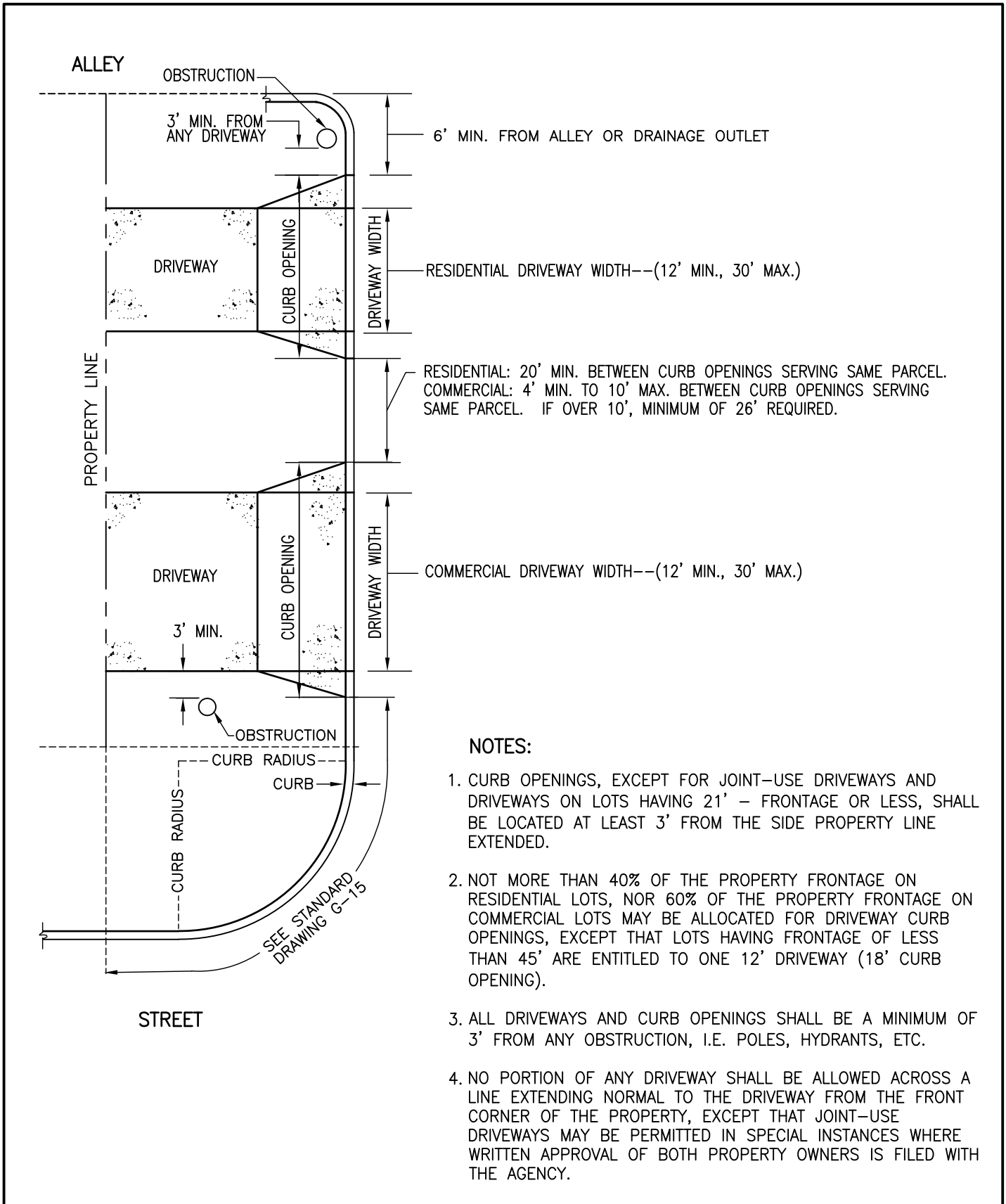

**NOTES:**

1. CURB OPENINGS, EXCEPT FOR JOINT-USE DRIVEWAYS AND DRIVEWAYS ON LOTS HAVING 21' – FRONTAGE OR LESS, SHALL BE LOCATED AT LEAST 3' FROM THE SIDE PROPERTY LINE EXTENDED.
2. NOT MORE THAN 40% OF THE PROPERTY FRONTAGE ON RESIDENTIAL LOTS, NOR 60% OF THE PROPERTY FRONTAGE ON COMMERCIAL LOTS MAY BE ALLOCATED FOR DRIVEWAY CURB OPENINGS, EXCEPT THAT LOTS HAVING FRONTAGE OF LESS THAN 45' ARE ENTITLED TO ONE 12' DRIVEWAY (18' CURB OPENING).
3. ALL DRIVEWAYS AND CURB OPENINGS SHALL BE A MINIMUM OF 3' FROM ANY OBSTRUCTION, I.E. POLES, HYDRANTS, ETC.
4. NO PORTION OF ANY DRIVEWAY SHALL BE ALLOWED ACROSS A LINE EXTENDING NORMAL TO THE DRIVEWAY FROM THE FRONT CORNER OF THE PROPERTY, EXCEPT THAT JOINT-USE DRIVEWAYS MAY BE PERMITTED IN SPECIAL INSTANCES WHERE WRITTEN APPROVAL OF BOTH PROPERTY OWNERS IS FILED WITH THE AGENCY.

Revision	By	Approved	Date
ORIGINAL		KERCHEVAL	12/75
UPDATED	MR	MR/CV	03/12
UPDATED	CV	CV	12/15
Reviewed	RP	S. Engeda	03/22

SAN DIEGO REGIONAL STANDARD DRAWING

**DRIVEWAY LOCATION AND WIDTH REQUIREMENTS**

RECOMMENDED BY THE SAN DIEGO REGIONAL STANDARDS COMMITTEE

*Samantha Engeda* 03/24/2022  
Chairperson R.C.E. 52241 Date

DRAWING NUMBER **G-16**

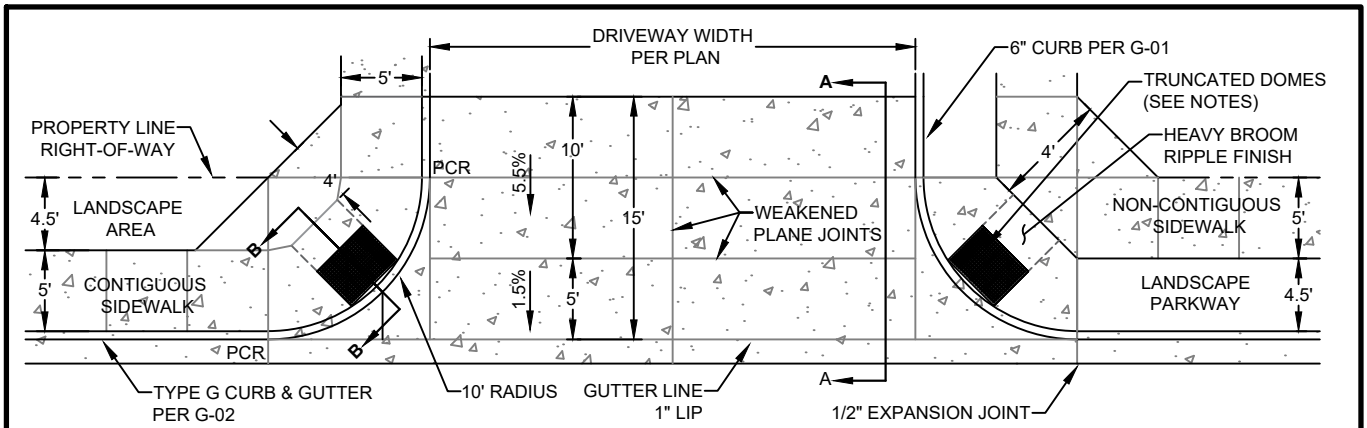

**TYPICAL PLAN**

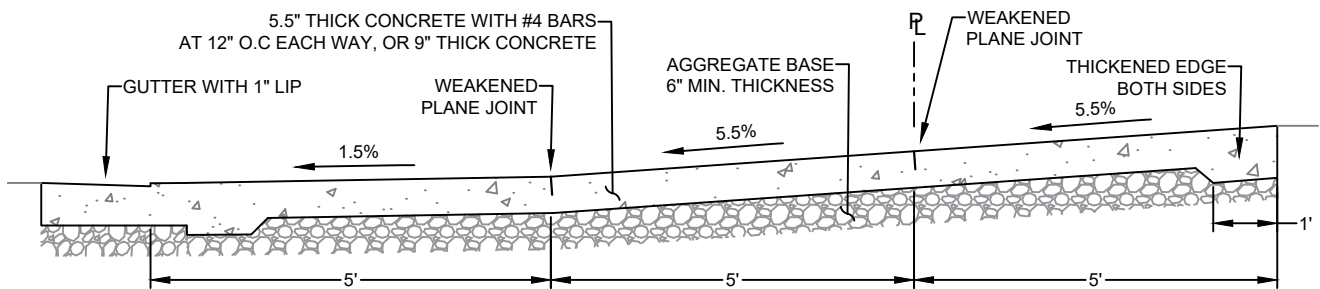

**SECTION A-A, DRIVEWAY CROSS SECTION**

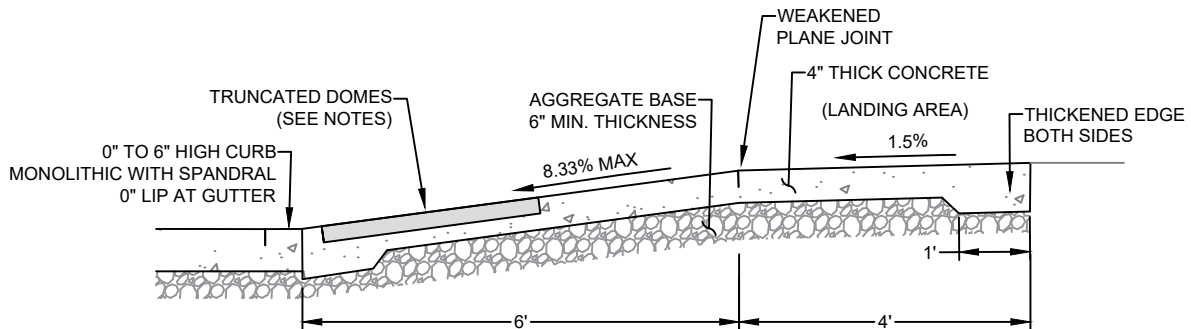

**SECTION B-B, PEDRAMP CROSS SECTION**

**GENERAL NOTES:**

1. CONCRETE SHALL BE 560-C-3250 PER STANDARD SPECIFICATIONS FOR PUBLIC WORKS CONSTRUCTION.
2. DRIVEWAY AREA SHALL CONTAIN #4 REINFORCING BARS AT 12" O.C. BOTH WAYS.
3. DRIVEWAY APRON SHALL CONTAIN 6" THICK AGGREGATE BASE MINIMUM.
4. SEE STANDARD DRAWING G-02 FOR CURB AND GUTTER DETAILS.
5. SEE STANDARD DRAWING G-07 FOR SIDEWALK DETAILS.
6. TRUNCATED DOMES SHALL BE 36"x48", FEDERAL YELLOW, REPLACEABLE TYPE, AND WET-SET.
7. SEE STANDARD DRAWING G-32A & B FOR ADDITIONAL NOTES.

REVISION	APPROVED	DATE	CITY OF SANTEE STANDARD DRAWING	APPROVED:	
ORIGINAL	C. SCHMITZ	8/13/2018		<b>COMMERCIAL DRIVEWAY / ALLEY APRON</b>	 PRINCIPAL CIVIL ENGINEER R.C.E. 60112    DATE: 8/13/2018
			DRAWING NUMBER		PW - 21

# PLOT PLAN

SAMPLE COPY FOR INFORMATION ONLY

SCALE 1" = 20'

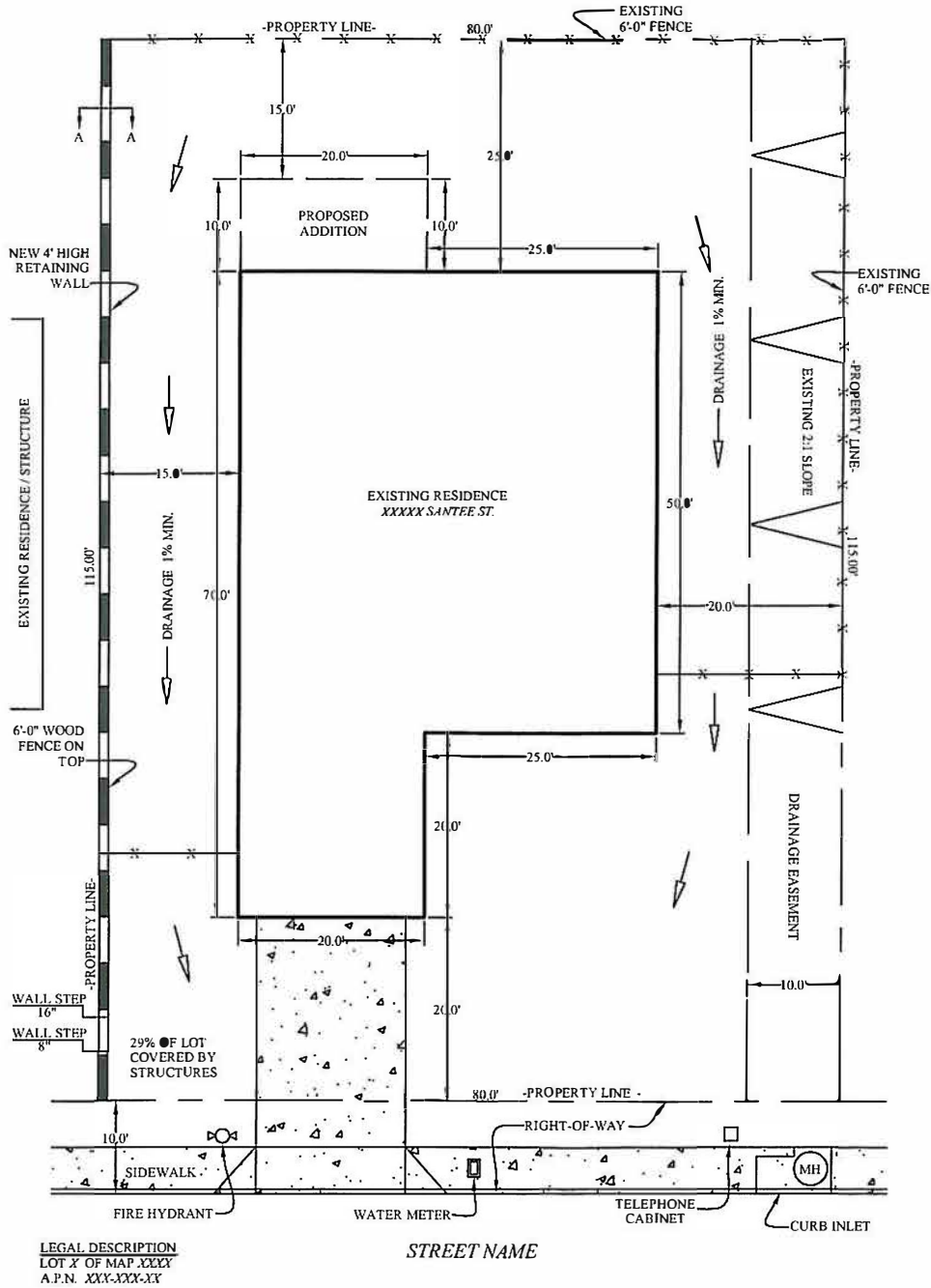

ACCEPTED: \_\_\_\_\_

BY: \_\_\_\_\_  
ENGINEERING DIVISION

**CITY OF SANTEE**

DEPARTMENT OF DEVELOPMENT SERVICES

PLANS FOR: A KEYSTONE RETAINING WALL, (SITE ADDRESS)

OWNER: JOE SANTEE

PHONE NO.: (619) XXX-XXXX

PERMIT NO. \_\_\_\_\_

SHEET X OF X

