



CITY OF SANTEE

Storm Water Best Management Practices—Graphic Symbols Legend

Why Does Storm Water Review My Plans?

Tenant improvement, renovation, development, and redevelopment projects have the potential to pollute our waterways. The Storm Water Program ensures that these types of activities use **Best Management Practices** in order to prevent pollution.

Visit our website for more information: www.SanteeH2o.org

Please Note:

This BMP Legend is not all inclusive, and only contains most common BMPs for Tenant Improvements. Reference the Caltrans Storm Water Quality Handbook—Construction Site Best management Practices Manual for installation specifications for each BMP.

The Manual is available online at:
www.dot.ca.gov/hq/construc/stormwater/CSBMPM_303_Final.pdf

MATERIALS & WASTE MANAGEMENT CONTROL BMPs:

- | | |
|-----------------------------------------|----------------------------------------------|
| WM—1 Material Delivery & Storage | WM—6 Hazardous Waste Management |
| WM—2 Material Use | WM—8 Concrete Waste Management |
| WM—3 Stockpile Management | WM—9 Sanitary/Septic Waste Management |
| WM—4 Spill Prevention & Control | WM—10 Liquid Waste Management |
| WM—5 Solid Waste Management | |

OTHER

- | | |
|---------------------------|--|
| PDS 659 Brow Ditch | |
| PDS 659 Berm | |
| Direction of Lot Drainage | |

TEMPORARY RUNOFF CONTROL BMPs:

- | | | | | |
|----------------------------------------------|---------------------------------|-------------------------------------------|---------------------------------|--|
| SS—6 | SS—8 Straw or Wood Mulch | | SC—5 Fiber Rolls | |
| SC—1 Silt Fence | | SC—6 | SC—8 Gravel or Sand Bags | |
| TC—1 Stabilized Construction Entrance | | SC—7 Street Sweeping & Vacuuming | | |
| TC—2 Construction Road Stabilization | | SC—10 Storm Drain Inlet Protection | | |

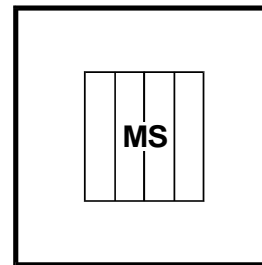
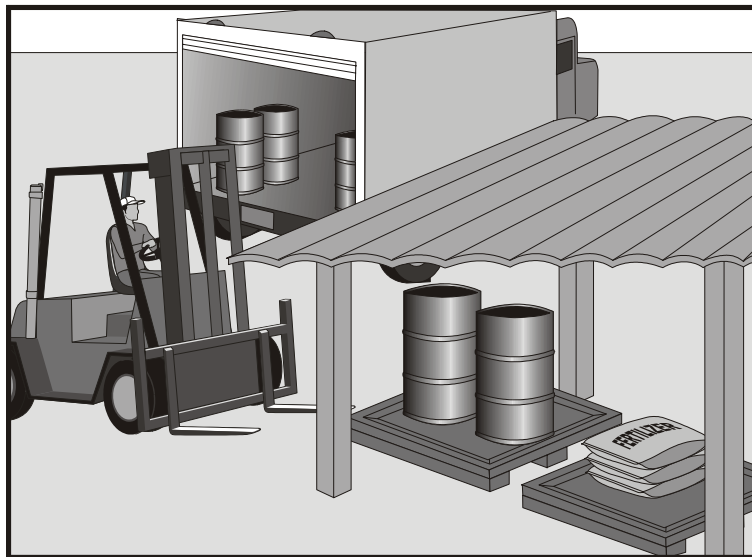

Standard Symbol

BMP Objectives

- Soil Stabilization
- Sediment Control
- Tracking Control
- Wind Erosion Control
- Non-Storm Water Management
- Materials and Waste Management

Definition and Purpose Procedures and practices for the proper handling and storage of materials in a manner that minimizes or eliminates the discharge of these materials to the storm drain system or to watercourses.

Appropriate Applications These procedures are implemented at all construction sites with delivery and storage of the following:

- Hazardous chemicals such as:
 - Acids,
 - lime,
 - glues,
 - adhesives,
 - paints,
 - solvents, and
 - curing compounds.
- Soil stabilizers and binders.
- Fertilizers.
- Detergents.
- Plaster.
- Petroleum products such as fuel, oil, and grease.
- Asphalt and concrete components.
- Pesticides and herbicides.

- Other materials that may be detrimental if released to the environment.
- Limitations
- Space limitation may preclude indoor storage.
 - Storage sheds must meet building & fire code requirements.

Standards and Specifications

General

- Train employees and subcontractors on the proper material delivery and storage practices.
- Temporary storage area shall be located away from vehicular traffic.
- Material Safety Data Sheets (MSDS) shall be supplied to the Resident Engineer (RE) for all materials stored.

Material Storage Areas and Practices

- Liquids, petroleum products, and substances listed in 40 CFR Parts 110, 117, or 302 shall be stored in approved containers and drums and shall be placed in temporary containment facilities for storage.
- Throughout the rainy season, each temporary containment facility shall have a permanent cover and side wind protection or be covered during non-working days and prior to and during rain events.
- A temporary containment facility shall provide for a spill containment volume able to contain precipitation from a 24-hour, 25-year storm event, plus the greater of 10% of the aggregate volume of all containers or 100% of the capacity of the largest container within its boundary, whichever is greater.
- A temporary containment facility shall be impervious to the materials stored therein for a minimum contact time of 72 hours.
- A temporary containment facility shall be maintained free of accumulated rainwater and spills. In the event of spills or leaks, accumulated rainwater and spills shall be collected and placed into drums. These liquids shall be handled as a hazardous waste unless testing determines them to be non-hazardous. All collected liquids or non-hazardous liquids shall be sent to an approved disposal site.
- Sufficient separation shall be provided between stored containers to allow for spill cleanup and emergency response access.
- Incompatible materials, such as chlorine and ammonia, shall not be stored in the same temporary containment facility.
- Materials shall be stored in their original containers and the original product labels shall be maintained in place in a legible condition. Damaged or otherwise illegible labels shall be replaced immediately.

-
- Bagged and boxed materials shall be stored on pallets and shall not be allowed to accumulate on the ground. To provide protection from wind and rain, throughout the rainy season, bagged and boxed materials shall be covered during non-working days and prior to rain events.
- Stockpiles shall be protected in accordance with BMP WM-3, “Stockpile Management.”
- Minimize the material inventory stored on-site (e.g., only a few days supply).
- Have proper storage instructions posted at all times in an open and conspicuous location.
- Do not store hazardous chemicals, drums, or bagged materials directly on the ground. Place these items on a pallet and when possible, under cover in secondary containment.
- Keep hazardous chemicals well labeled and in their original containers.
- Keep ample supply of appropriate spill clean up material near storage areas.
- Also see BMP WM-6, “Hazardous Waste Management”, for storing of hazardous materials.

Material Delivery Practices

- Keep an accurate, up-to-date inventory of material delivered and stored on-site.
- Employees trained in emergency spill clean-up procedures shall be present when dangerous materials or liquid chemicals are unloaded.

Spill Clean-up

- Contain and clean up any spill immediately.
- If significant residual materials remain on the ground after construction is complete, properly remove and dispose any hazardous materials or contaminated soil.
- See BMP WM-4, “Spill Prevention and Control”, for spills of chemicals and/or hazardous materials.

- Maintenance and Inspection
- Storage areas shall be kept clean, well organized, and equipped with ample clean-up supplies as appropriate for the materials being stored.
 - Perimeter controls, containment structures, covers, and liners shall be repaired or replaced as needed to maintain proper function.
 - Inspect storage areas before and after rainfall events, and at least weekly during other times. Collect and place into drums any spills or accumulated rainwater.

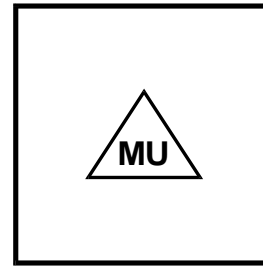
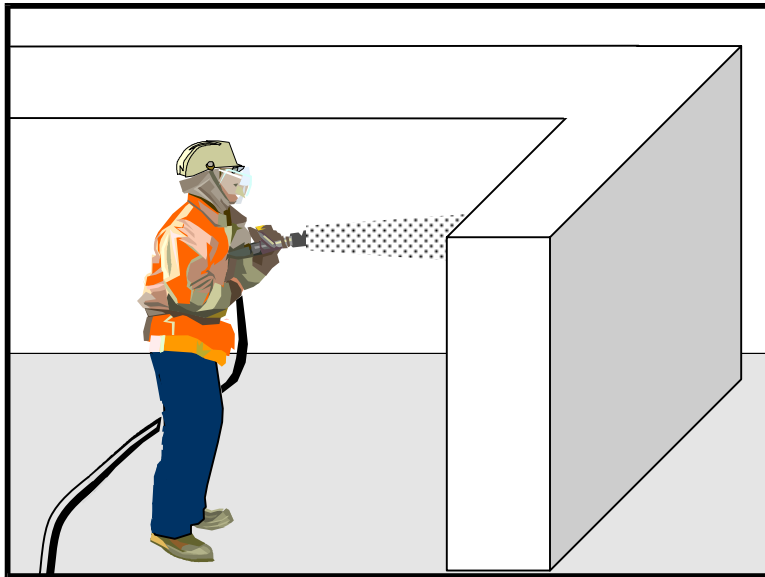

Standard Symbol

- BMP Objectives**
- Soil Stabilization
 - Sediment Control
 - Tracking Control
 - Wind Erosion Control
 - Non-Storm Water Management
 - Materials and Waste Management

Definition and Purpose These are procedures and practices for use of construction material in a manner that minimizes or eliminates the discharge of these materials to the storm drain system or to watercourses.

Appropriate Applications This BMP applies to all construction projects. These procedures apply when the following materials are used or prepared on site:

- Hazardous chemicals such as:
 - Acids,
 - lime,
 - glues,
 - adhesives,
 - paints,
 - solvents, and
 - curing compounds.
- Soil stabilizers and binders.
- Fertilizers.
- Detergents.
- Plaster.
- Petroleum products such as fuel, oil, and grease.
- Asphalt and concrete components.
- Pesticides and herbicides.
- Other materials that may be detrimental if released to the environment.

- Limitations** ■ Safer alternative building and construction products may not be available or suitable in every instance.
- Standards and Specifications** ■ Material Safety Data Sheets (MSDS) shall be supplied to the Resident Engineer (RE) for all materials.
 - Latex paint and paint cans, used brushes, rags, absorbent materials, and drop cloths, when thoroughly dry and are no longer hazardous, may be disposed of with other construction debris.
 - Do not remove the original product label, it contains important safety and disposal information. Use the entire product before disposing of the container.
 - Mix paint indoors, or in a containment area. Never clean paintbrushes or rinse paint containers into a street, gutter, storm drain or watercourse. Dispose of any paint thinners, residue and sludge(s), that cannot be recycled, as hazardous waste.
 - For water-based paint, clean brushes to the extent practical, and rinse to a drain leading to a sanitary sewer where permitted, or into a concrete washout pit. For oil-based paints, clean brushes to the extent practical and filter and reuse thinners and solvents.
 - Use recycled and less hazardous products when practical. Recycle residual paints, solvents, non-treated lumber, and other materials.
 - Use materials only where and when needed to complete the construction activity. Use safer alternative materials as much as possible. Reduce or eliminate use of hazardous materials on-site when practical.
 - Do not over-apply fertilizers and pesticides. Prepare only the amount needed. Strictly follow the recommended usage instructions. Apply surface dressings in smaller applications, as opposed to large applications, to allow time for it to work in and to avoid excess materials being carried off-site by runoff.
 - Application of herbicides and pesticides shall be performed by a licensed applicator.
 - Contractors are required to complete the “Report of Chemical Spray Forms” when spraying herbicides and pesticides.
 - Keep an ample supply of spill clean up material near use areas. Train employees in spill clean up procedures.
 - Avoid exposing applied materials to rainfall and runoff unless sufficient time has been allowed for them to dry.
- Maintenance and Inspections** ■ Spot check employees and subcontractors monthly throughout the job to ensure appropriate practices are being employed.

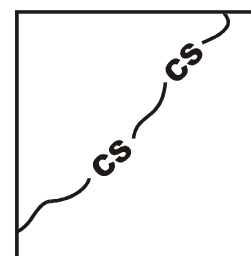

Standard Symbol

- BMP Objectives**

 - Soil Stabilization
 - Sediment Control
 - Tracking Control
 - Wind Erosion Control
 - Non-Storm Water Management
 - Materials and Waste Management

Definition and Purpose Stockpile management procedures and practices are designed to reduce or eliminate air and storm water pollution from stockpiles of soil, and paving materials such as portland cement concrete (PCC) rubble, asphalt concrete (AC), asphalt concrete rubble, aggregate base, aggregate subbase or pre-mixed aggregate, asphalt binder (so called “cold mix” asphalt) and pressure treated wood.

Appropriate Applications Implemented in all projects that stockpile soil and other materials.

Limitations ■ None identified

- Standards and Specifications**
- Protection of stockpiles is a year-round requirement.
 - Locate stockpiles a minimum of 15 m (50 ft) away from concentrated flows of storm water, drainage courses, and inlets.
 - Implement wind erosion control practices as appropriate on all stockpiled material. For specific information see BMP WE-1, “Wind Erosion Control.”
 - Stockpiles of contaminated soil shall be managed in accordance with BMP WM-7, “Contaminated Soil Management.”
 - Bagged materials should be placed on pallets and under cover.

Protection of Non-Active Stockpiles

Non-active stockpiles of the identified materials shall be protected further as follows:

- ***Soil stockpiles:***

- During the rainy seasons, soil stockpiles shall be covered or protected with soil stabilization measures and a temporary perimeter sediment barrier at all times.
- During the non-rainy season, soil stockpiles shall be covered and protected with a temporary perimeter sediment barrier prior to the onset of precipitation.

- ***Stockpiles of portland cement concrete rubble, asphalt concrete, asphalt concrete rubble, aggregate base, or aggregate subbase:***

- During the rainy season, the stockpiles shall be covered or protected with a temporary perimeter sediment barrier at all times.
- During the non-rainy season, the stockpiles shall be covered or protected with a temporary perimeter sediment barrier prior to the onset of precipitation.

- ***Stockpiles of “cold mix”:***

- During the rainy season, cold mix stockpiles shall be placed on and covered with plastic or comparable material at all times.
- During the non-rainy season, cold mix stockpiles shall be placed on and covered with plastic or comparable material prior to the onset of precipitation.

- ***Stockpiles/Storage of pressure treated wood with copper, chromium, and arsenic or ammonical, copper, zinc, and arsenate:***

- During the rainy season, treated wood shall be covered with plastic or comparable material at all times.
- During the non-rainy season, treated wood shall be covered with plastic or comparable material and shall be placed on pallets prior to the onset of precipitation.

Protection of Active Stockpiles

Active stockpiles of the identified materials shall be protected further as follows:

- All stockpiles shall be covered, stabilized, or protected with a temporary linear sediment barrier prior to the onset of precipitation.
- Stockpiles of “cold mix” shall be placed on and covered with plastic or comparable material prior to the onset of precipitation.

Maintenance and Inspections

- Repair and/or replace perimeter controls and covers as needed, or as directed by the RE, to keep them functioning properly. Sediment shall be removed when sediment accumulation reaches one-third (1/3) of the barrier height.

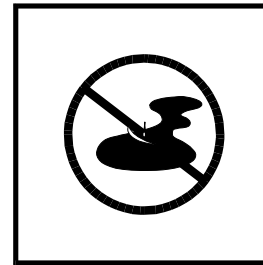
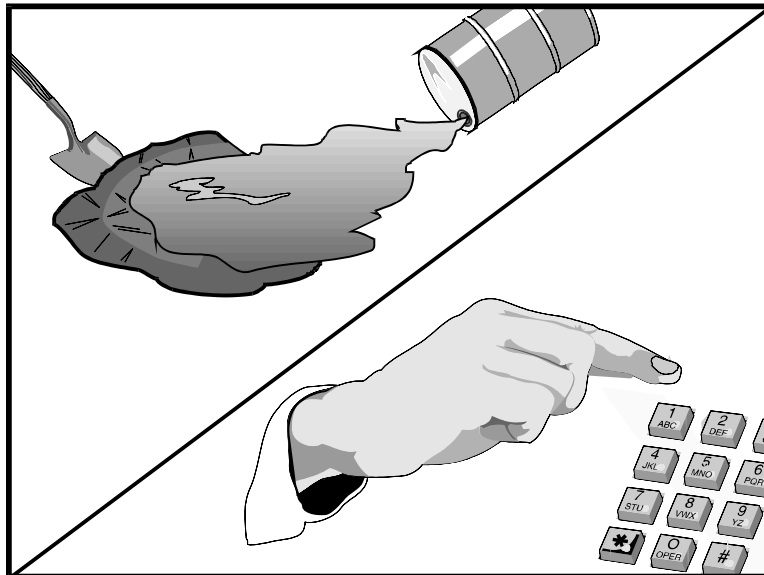

Standard Symbol

BMP Objectives

- Soil Stabilization
- Sediment Control
- Tracking Control
- Wind Erosion Control
- Non-Storm Water Management
- Materials and Waste Management

Definition and Purpose These procedures and practices are implemented to prevent and control spills in a manner that minimizes or prevents the discharge of spilled material to the drainage system or watercourses.

Appropriate Application This best management practice (BMP) applies to all construction projects. Spill control procedures are implemented anytime chemicals and/or hazardous substances are stored. Substances may include, but are not limited to:

- Soil stabilizers/binders.
- Dust Palliatives.
- Herbicides.
- Growth inhibitors.
- Fertilizers.
- Deicing/anti-icing chemicals.
- Fuels.
- Lubricants.
- Other petroleum distillates.

To the extent that the work can be accomplished safely, spills of oil, petroleum products, substances listed under 40 CFR parts 110, 117, and 302, and sanitary and septic wastes shall be contained and cleaned up immediately.

Limitations ■ This BMP only applies to spills caused by the contractor.

■ Procedures and practices presented in this BMP are general. Contractor shall identify appropriate practices for the specific materials used or stored on-site.

Standards and Specifications ■ To the extent that it doesn't compromise clean up activities, spills shall be covered and protected from storm water run-on during rainfall.

■ Spills shall not be buried or washed with water.

■ Used clean up materials, contaminated materials, and recovered spill material that is no longer suitable for the intended purpose shall be stored and disposed of in conformance with the special provisions.

■ Water used for cleaning and decontamination shall not be allowed to enter storm drains or watercourses and shall be collected and disposed of in accordance with BMP WM-10, "Liquid Waste Management."

■ Water overflow or minor water spillage shall be contained and shall not be allowed to discharge into drainage facilities or watercourses.

■ Proper storage, clean-up and spill reporting instruction for hazardous materials stored or used on the project site shall be posted at all times in an open, conspicuous and accessible location.

■ Waste storage areas shall be kept clean, well organized and equipped with ample clean-up supplies as appropriate for the materials being stored. Perimeter controls, containment structures, covers and liners shall be repaired or replaced as needed to maintain proper function.

Education

■ Educate employees and subcontractors on what a "significant spill" is for each material they use, and what is the appropriate response for "significant" and "insignificant" spills.

■ Educate employees and subcontractors on potential dangers to humans and the environment from spills and leaks.

■ Hold regular meetings to discuss and reinforce appropriate disposal procedures (incorporate into regular safety meetings).

■ Establish a continuing education program to indoctrinate new employees.

■ The Contractor's Water Pollution Control Manager (WPCM) shall oversee and enforce proper spill prevention and control measures.

Cleanup and Storage Procedures

■ Minor Spills

- Minor spills typically involve small quantities of oil, gasoline, paint, etc., which can be controlled by the first responder at the discovery of the spill.
- Use absorbent materials on small spills rather than hosing down or burying the spill.
- Remove the absorbent materials promptly and dispose of properly.
- The practice commonly followed for a minor spill is:
 - Contain the spread of the spill.
 - Recover spilled materials.
 - Clean the contaminated area and/or properly dispose of contaminated materials.

■ Semi-Significant Spills

- Semi-significant spills still can be controlled by the first responder along with the aid of other personnel such as laborers and the foreman, etc. This response may require the cessation of all other activities.
- Clean up spills immediately:
 - Notify the project foreman immediately. The foreman shall notify the Resident Engineer (RE).
 - Contain spread of the spill.
 - If the spill occurs on paved or impermeable surfaces, clean up using "dry" methods (absorbent materials, cat litter and/or rags). Contain the spill by encircling with absorbent materials and do not let the spill spread widely.
 - If the spill occurs in dirt areas, immediately contain the spill by constructing an earthen dike. Dig up and properly dispose of contaminated soil.
 - If the spill occurs during rain, cover spill with tarps or other material to prevent contaminating runoff.

- Significant/Hazardous Spills

- For significant or hazardous spills that cannot be controlled by personnel in the immediate vicinity, the following steps shall be taken:
 - Notify the RE immediately and follow up with a written report.
 - Notify the local emergency response by dialing 911. In addition to 911, the contractor will notify the proper county officials. It is the contractor's responsibility to have all emergency phone numbers at the construction site.
 - Notify the Governor's Office of Emergency Services Warning Center, (805) 852-7550.
 - For spills of federal reportable quantities, in conformance with the requirements in 40 CFR parts 110,119, and 302, the contractor shall notify the National Response Center at (800) 424-8802.
 - Notification shall first be made by telephone and followed up with a written report.
 - The services of a spills contractor or a Haz-Mat team shall be obtained immediately. Construction personnel shall not attempt to clean up the spill until the appropriate and qualified staff have arrived at the job site.
 - Other agencies which may need to be consulted include, but are not limited to, the Fire Department, the Public Works Department, the Coast Guard, the Highway Patrol, the City/County Police Department, Department of Toxic Substances, California Division of Oil and Gas, Cal/OSHA, RWQCB, etc.

Maintenance and Inspection

- Verify weekly that spill control clean up materials are located near material storage, unloading, and use areas.
- Update spill prevention and control plans and stock appropriate clean-up materials whenever changes occur in the types of chemicals used or stored onsite.

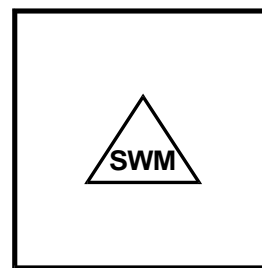
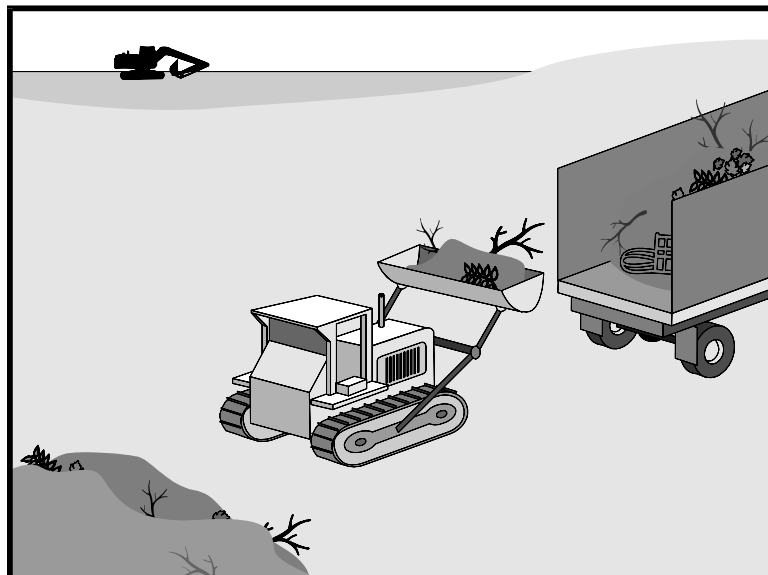

Standard Symbol

BMP Objectives

- Soil Stabilization
- Sediment Control
- Tracking Control
- Wind Erosion Control
- Non-Storm Water Management
- Materials and Waste Management

Definition and Purpose Solid waste management procedures and practices are designed to minimize or eliminate the discharge of pollutants to the drainage system or to watercourses as a result of the creation, stockpiling, or removal of construction site wastes.

Appropriate Applications Solid waste management procedures and practices are implemented on all construction projects that generate solid wastes.

Solid wastes include but are not limited to:

- Construction wastes including brick, mortar, timber, steel and metal scraps, sawdust, pipe and electrical cuttings, non-hazardous equipment parts, styrofoam and other materials used to transport and package construction materials.
- Highway planting wastes, including vegetative material, plant containers, and packaging materials.
- Litter, including food containers, beverage cans, coffee cups, paper bags, plastic wrappers, and smoking materials, including litter generated by the public.

Limitations ■ Temporary stockpiling of certain construction wastes may not necessitate stringent drainage related controls during the non-rainy season or in desert areas with low rainfall.

Standards and Specifications

Education

- The Contractor's Water Pollution Control Manager (WPCM) shall oversee and enforce proper solid waste procedures and practices.
- Instruct employees and subcontractors on identification of solid waste and hazardous waste.
- Educate employees and subcontractors on solid waste storage and disposal procedures.
- Hold regular meetings to discuss and reinforce disposal procedures (incorporate into regular safety meetings).
- Require that employees and subcontractors follow solid waste handling and storage procedures.
- Prohibit littering by employees, subcontractors, and visitors.
- Wherever possible, minimize production of solid waste materials.

Collection, Storage, and Disposal

- Dumpsters of sufficient size and number shall be provided to contain the solid waste generated by the project and properly serviced.
- Littering on the project site shall be prohibited.
- To prevent clogging of the storm drainage system litter and debris removal from drainage grates, trash racks, and ditch lines shall be a priority.
- Trash receptacles shall be provided in the Contractor's yard, field trailer areas, and at locations where workers congregate for lunch and break periods.
- Construction debris and litter from work areas within the construction limits of the project site shall be collected and placed in watertight dumpsters at least weekly regardless of whether the litter was generated by the Contractor, the public, or others. Collected litter and debris shall not be placed in or next to drain inlets, storm water drainage systems or watercourses.
- Full dumpsters shall be removed from the project site and the contents shall be disposed of outside the highway right-of-way in conformance with the provisions in the Standard Specifications Section 7-1.13.
- Litter stored in collection areas and containers shall be handled and disposed of by trash hauling contractors.
- Construction debris and waste shall be removed from the site every two weeks or as directed by the RE.

- Construction material visible to the public shall be stored or stacked in an orderly manner to the satisfaction of the RE.
- Storm water run-on shall be prevented from contacting stored solid waste through the use of berms, dikes, or other temporary diversion structures or through the use of measures to elevate waste from site surfaces.
- Solid waste storage areas shall be located at least 15 m (50 ft) from drainage facilities and watercourses and shall not be located in areas prone to flooding or ponding.
- Except during fair weather, construction and highway planting waste not stored in watertight dumpsters shall be securely covered from wind and rain by covering the waste with tarps or plastic sheeting or protected in conformance with the applicable Disturbed Soil Area protection section.
- Dumpster washout on the project site is not allowed.
- Notify trash hauling contractors that only watertight dumpsters are acceptable for use on-site.
- Plan for additional containers during the demolition phase of construction.
- Plan for more frequent pickup during the demolition phase of construction.
- Construction waste shall be stored in a designated area approved by the RE.
- Segregate potentially hazardous waste from non-hazardous construction site waste.
- Keep the site clean of litter debris.
- Make sure that toxic liquid wastes (e.g., used oils, solvents, and paints) and chemicals (e.g., acids, pesticides, additives, curing compounds) are not disposed of in dumpsters designated for construction debris.
- Dispose of non-hazardous waste in accordance with Standard Specification 7-1.13, Disposal of Material Outside the Highway Right of Way.
- For disposal of hazardous waste, see BMP WM-6, “Hazardous Waste Management.” Have hazardous waste hauled to an appropriate disposal and/or recycling facility.
- Salvage or recycle useful vegetation debris, packaging and/or surplus building materials when practical. For example, trees and shrubs from land clearing can be converted into wood chips, then used as mulch on graded areas. Wood pallets, cardboard boxes, and construction scraps can also be recycled.

- Maintenance and Inspection
- The WPCM shall monitor onsite solid waste storage and disposal procedures.
 - Police site for litter and debris.

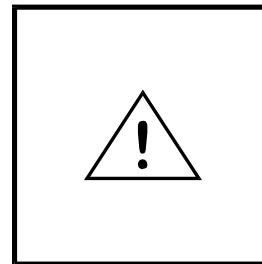
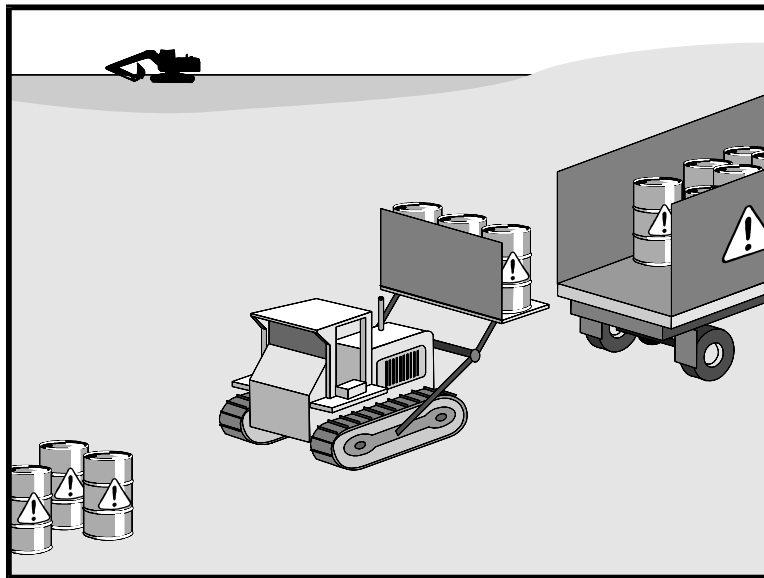

Standard Symbol

BMP Objectives

- Soil Stabilization
- Sediment Control
- Tracking Control
- Wind Erosion Control
- Non-Storm Water Management
- Materials and Waste Management

Definition and Purpose These are procedures and practices to minimize or eliminate the discharge of pollutants from construction site hazardous waste to the storm drain systems or to watercourses.

Appropriate Applications

- This best management practice (BMP) applies to all construction projects.
- Hazardous waste management practices are implemented on construction projects that generate waste from the use of:

- Petroleum Products,
- Asphalt Products,
- Concrete Curing Compounds,
- Pesticides,
- Acids,
- Paints,
- Stains,
- Solvents,
- Wood Preservatives,
- Roofing Tar, or
- Any materials deemed a hazardous waste in California, Title 22 Division 4.5, or listed in 40 CFR Parts 110, 117, 261, or 302.

- Limitations**
- Nothing in this BMP relieves the Contractor from responsibility for compliance with federal, state, and local laws regarding storage, handling, transportation, and disposal of hazardous wastes.
 - This BMP does not cover aerially deposited lead (ADL) soils. For ADL soils refer to BMP WM-7, “Contaminated Soil Management,” and the project special provisions.

Standards and Specifications

Education

- Educate employees and subcontractors on hazardous waste storage and disposal procedures.
- Educate employees and subcontractors on potential dangers to humans and the environment from hazardous wastes.
- Instruct employees and subcontractors on safety procedures for common construction site hazardous wastes.
- Instruct employees and subcontractors in identification of hazardous and solid waste.
- Hold regular meetings to discuss and reinforce hazardous waste management procedures (incorporate into regular safety meetings).
- The Contractor’s Water Pollution Control Manager (WPCM) shall oversee and enforce proper hazardous waste management procedures and practices.
- Make sure that hazardous waste is collected, removed, and disposed of only at authorized disposal areas.

Storage Procedures

- Wastes shall be stored in sealed containers constructed of a suitable material and shall be labeled as required by Title 22 CCR, Division 4.5 and 49 CFR Parts 172,173, 178, and 179.
- All hazardous waste shall be stored, transported, and disposed as required in Title 22 CCR, Division 4.5 and 49 CFR 261-263.
- Waste containers shall be stored in temporary containment facilities that shall comply with the following requirements:
 - Temporary containment facility shall provide for a spill containment volume able to contain precipitation from a 24-hour, 25 year storm event, plus the greater of 10% of the aggregate volume of all containers or 100% of the capacity of the largest tank within its boundary, whichever is greater.

- Temporary containment facility shall be impervious to the materials stored there for a minimum contact time of 72 hours.
 - Temporary containment facilities shall be maintained free of accumulated rainwater and spills. In the event of spills or leaks accumulated rainwater and spills shall be placed into drums after each rainfall. These liquids shall be handled as a hazardous waste unless testing determines them to be non-hazardous. Non-hazardous liquids shall be sent to an approved disposal site.
 - Sufficient separation shall be provided between stored containers to allow for spill cleanup and emergency response access.
 - Incompatible materials, such as chlorine and ammonia, shall not be stored in the same temporary containment facility.
 - Throughout the rainy season, temporary containment facilities shall be covered during non-working days, and prior to rain events. Covered facilities may include use of plastic tarps for small facilities or constructed roofs with overhangs. A storage facility having a solid cover and sides is preferred to a temporary tarp. Storage facilities shall be equipped with adequate ventilation.
- Drums shall not be overfilled and wastes shall not be mixed.
 - Unless watertight, containers of dry waste shall be stored on pallets.
 - Paint brushes and equipment for water and oil based paints shall be cleaned within a contained area and shall not be allowed to contaminate site soils, watercourses or drainage systems. Waste paints, thinners, solvents, residues, and sludges that cannot be recycled or reused shall be disposed of as hazardous waste. When thoroughly dry, latex paint and paint cans, used brushes, rags, absorbent materials, and drop cloths shall be disposed of as solid waste.
 - Ensure that adequate hazardous waste storage volume is available.
 - Ensure that hazardous waste collection containers are conveniently located.
 - Designate hazardous waste storage areas on site away from storm drains or watercourses and away from moving vehicles and equipment to prevent accidental spills.
 - Minimize production or generation of hazardous materials and hazardous waste on the job site.
 - Use containment berms in fueling and maintenance areas and where the potential for spills is high.

- Segregate potentially hazardous waste from non-hazardous construction site debris.
- Keep liquid or semi-liquid hazardous waste in appropriate containers (closed drums or similar) and under cover.
- Clearly label all hazardous waste containers with the waste being stored and the date of accumulation.
- Place hazardous waste containers in secondary containment.
- Do not allow potentially hazardous waste materials to accumulate on the ground.
- Do not mix wastes.

Disposal Procedures

- Waste shall be disposed of outside the highway right-of-way within 90 days of being generated, or as directed by the Resident Engineer (RE). In no case shall hazardous waste storage exceed requirements in Title 22 CCR, Section 66262.34.
- Waste shall be disposed of by a licensed hazardous waste transporter at an authorized and licensed disposal facility or recycling facility utilizing properly completed Uniform Hazardous Waste Manifest forms.
- A Department of Health Services (DHS) certified laboratory shall sample waste and classify it to determine the appropriate disposal facility.
- Make sure that toxic liquid wastes (e.g., used oils, solvents, and paints) and chemicals (e.g., acids, pesticides, additives, curing compounds) are not disposed of in dumpsters designated for solid waste construction debris.
- Properly dispose of rainwater in secondary containment that may have mixed with hazardous waste.
- Recycle any useful material such as used oil or water-based paint when practical.
- Attention is directed to "Hazardous Material", "Contaminated Material", and "Aerially Deposited Lead" of the contract documents regarding the handling and disposal of hazardous materials.

Maintenance and Inspection

- A foreman and/or construction supervisor shall monitor on-site hazardous waste storage and disposal procedures.
- Waste storage areas shall be kept clean, well organized, and equipped with ample clean-up supplies as appropriate for the materials being stored.
- Storage areas shall be inspected in conformance with the provisions in the contract documents.
- Perimeter controls, containment structures, covers, and liners shall be repaired or replaced as needed to maintain proper function.
- Hazardous spills shall be cleaned up and reported in conformance with the applicable Material Safety Data Sheet (MSDS) and the instructions posted at the project site.
- The National Response Center, at (800) 424-8802, shall be notified of spills of Federal reportable quantities in conformance with the requirements in 40 CFR parts 110, 117, and 302.
- Copy of the hazardous waste manifests shall be provided to the RE.

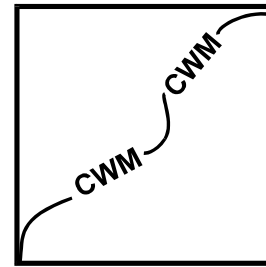
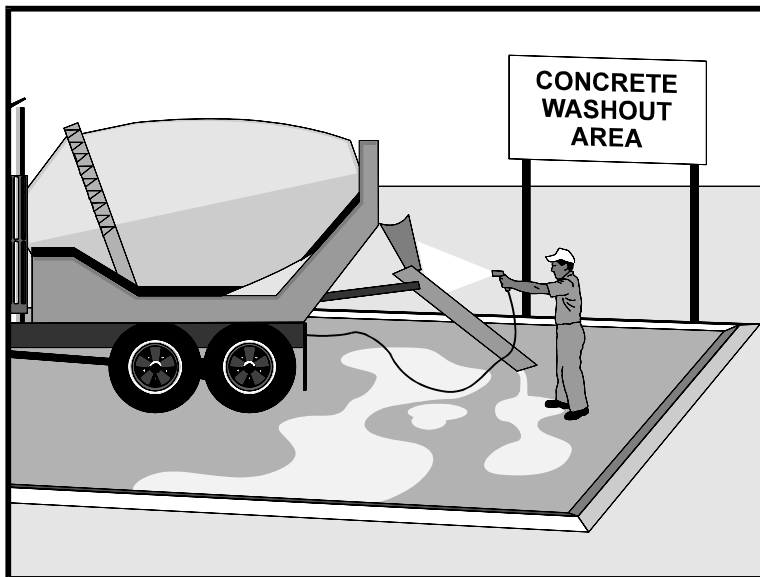

Standard Symbol

BMP Objectives

- Soil Stabilization
- Sediment Control
- Tracking Control
- Wind Erosion Control
- Non-Storm Water Management
- Materials and Waste Management

Definition and Purpose These are procedures and practices that are designed to minimize or eliminate the discharge of concrete waste materials to the storm drain systems or watercourses.

- Appropriate Applications**
- Concrete waste management procedures and practices are implemented on construction projects where concrete is used as a construction material or where concrete dust and debris result from demolition activities.
 - Where slurries containing portland cement concrete (PCC) or asphalt concrete (AC) are generated, such as from sawcutting, coring, grinding, grooving, and hydro-concrete demolition.
 - Where concrete trucks and other concrete-coated equipment are washed on site, when approved by the Resident Engineer (RE). See also NS-8, "Vehicle and Equipment Cleaning."
 - Where mortar-mixing stations exist.

Limitations ■ None identified.

Standards and Specifications **Education**

- Educate employees, subcontractors, and suppliers on the concrete waste management techniques described herein.
- The Contractor's Water Pollution Control Manager (WPCM) shall oversee and enforce concrete waste management procedures.

Concrete Slurry Wastes

- PCC and AC waste shall not be allowed to enter storm drains or watercourses.

- PCC and AC waste shall be collected and properly disposed of outside the highway right-of-way in conformance with Standard Specifications Section 7-1.13 or placed in a temporary concrete washout facility as shown in the figures on Pages 5 and 6.
- Disposal of hardened PCC and AC waste shall be in conformance with Standard Specifications Section 15-3.02.
- A sign shall be installed adjacent to each temporary concrete washout facility to inform concrete equipment operators to utilize the proper facilities as shown on Page 6.
- A foreman and/or construction supervisor shall monitor onsite concrete working tasks, such as saw cutting, coring, grinding and grooving to ensure proper methods are implemented.
- Do not allow saw-cut PCC slurry to enter storm drains or watercourses. See also BMP NS-3, "Paving and Grinding Operations;" and BMP WM-10, "Liquid Waste Management." Residue from grinding operations shall be picked up by means of a vacuum attachment to the grinding machine. Saw cutting residue shall not be allowed to flow across the pavement, and shall not be left on the surface of the pavement.
- Vacuum slurry residue and dispose in a temporary facility (as described in Onsite Temporary Concrete Washout Facility, Concrete Transit Truck Washout Procedures, below) and allow slurry to dry. Dispose of dry slurry residue in accordance with BMP WM-5, "Solid Waste Management", or, for on-site disposal, in accordance with Standard Specification 15-3.02, Removal Methods.
- Collect and dispose of residue from grooving and grinding operations in accordance with Standard Specifications Section 42-1.02 and 42-2.02.

Onsite Temporary Concrete Washout Facility, Concrete Transit Truck Washout Procedures

- Temporary concrete washout facilities shall be located a minimum of 15 m (50 ft) from storm drain inlets, open drainage facilities, and watercourses, unless determined infeasible by the RE. Each facility shall be located away from construction traffic or access areas to prevent disturbance or tracking.
- A sign shall be installed adjacent to each washout facility to inform concrete equipment operators to utilize the proper facilities. The sign shall be installed as shown on the plans and in conformance with the provisions in Standard Specifications Section 56-2, Roadside Signs.

- Temporary concrete washout facilities shall be constructed above grade or below grade at the option of the Contractor. Temporary concrete washout facilities shall be constructed and maintained in sufficient quantity and size to contain all liquid and concrete waste generated by washout operations.
- Temporary washout facilities shall have a temporary pit or bermed areas of sufficient volume to completely contain all liquid and waste concrete materials generated during washout procedures.
- Perform washout of concrete mixer trucks in designated areas only.
- Wash concrete only from mixer truck chutes into approved concrete washout facility. Washout may be collected in an impermeable bag for disposal.
- Pump excess concrete in concrete pump bin back into concrete mixer truck.
- Concrete washout from concrete pumper bins can be washed into concrete pumper trucks and discharged into designated washout area or properly disposed offsite.
- Once concrete wastes are washed into the designated area and allowed to harden, the concrete shall be broken up, removed, and disposed of per BMP WM-5, "Solid Waste Management", and in conformance with the provisions in Standard Specifications Section 15-3.02, "Removal Methods."

Temporary Concrete Washout Facility Type "Above Grade"

- Temporary concrete washout facility Type "Above Grade" shall be constructed as shown on Page 5 or 6, with a recommended minimum length and minimum width of 3 m (10 ft), but with sufficient quantity and volume to contain all liquid and concrete waste generated by washout operations. The length and width of a facility may be increased, at the Contractor's expense, upon approval from the RE.
- Straw bales, wood stakes, and sandbag materials shall conform to the provisions in BMP SC-9, "Straw Bale Barrier."
- Plastic lining material shall be a minimum of 10-mil polyethylene sheeting and shall be free of holes, tears or other defects that compromise the impermeability of the material.
- Portable delineators shall conform to the provisions in Standard Specifications Section 12-3.04, "Portable Delineators.". The delineator bases shall be cemented to the pavement in the same manner as provided for cementing pavement markers to pavement in Standard Specifications Section 85-1.06, "Placement." Portable delineators shall be applied only to a clean, dry surface.

Temporary Concrete Washout Facility (Type Below Grade)

- Temporary concrete washout facility Type “Below Grade” shall be constructed as shown on page 6, with a recommended minimum length and minimum width of 3m (10 ft). The quantity and volume shall be sufficient to contain all liquid and concrete waste generated by washout operations. The length and width of a facility may be increased, at the Contractor’s expense, upon approval of the RE. Lath and flagging shall be commercial type.
- Plastic lining material shall be a minimum of 10-mil polyethylene sheeting and shall be free of holes, tears or other defects that compromise the impermeability of the material.
- The soil base shall be prepared free of rocks or other debris that may cause tears or holes in the plastic lining material.

Removal of Temporary Concrete Washout Facilities

- When temporary concrete washout facilities are no longer required for the work, as determined by the RE, the hardened concrete shall be removed and disposed of in conformance with the provisions in Standard Specifications Section 15-3.02. Disposal of PCC slurries or liquid waste shall be disposed of outside the highway right-of-way in conformance with provisions of Standard Specifications Section 7-1-13. Materials used to construct temporary concrete washout facilities shall become the property of the Contractor, shall be removed from the site of the work, and shall be disposed of outside the highway right-of-way in conformance with the provisions of the Standard Specifications, Section 7-1.13.
- Holes, depressions or other ground disturbance caused by the removal of the temporary concrete washout facilities shall be backfilled and repaired in conformance with the provisions in Standard Specifications Section 15-1.02, "Preservation of Property."

Maintenance and Inspection

- The Contractor’s Water Pollution Control Manager (WPCM) shall monitor on site concrete waste storage and disposal procedures at least weekly or as directed by the RE.
- The WPCM shall monitor concrete working tasks, such as saw cutting, coring, grinding and grooving daily to ensure proper methods are employed or as directed by the RE.

- Temporary concrete washout facilities shall be maintained to provide adequate holding capacity with a minimum freeboard of 100 mm (4 inches) for above grade facilities and 300 mm (12 inches) for below grade facilities. Maintaining temporary concrete washout facilities shall include removing and disposing of hardened concrete and returning the facilities to a functional condition. Hardened concrete materials shall be removed and disposed of in conformance with the provisions in Standard Specifications Section 15-3.02, "Removal Methods."
- Existing facilities must be cleaned, or new facilities must be constructed and ready for use once the washout is 75% full.
- Temporary concrete washout facilities shall be inspected for damage (i.e. tears in PVC liner, missing sand bags, etc.). Damaged facilities shall be repaired.

Concrete Waste Management

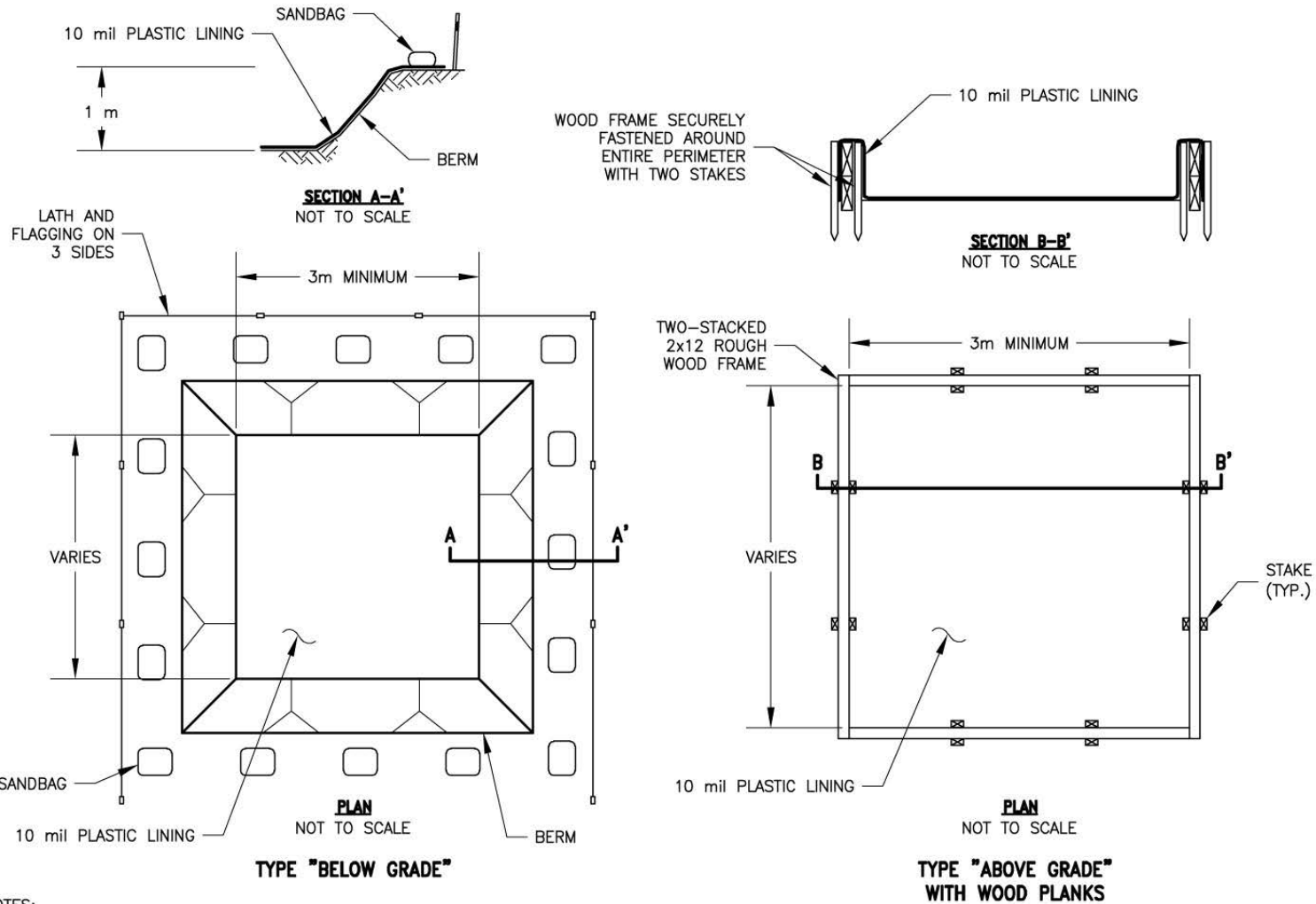

NOTES:

1. ACTUAL LAYOUT DETERMINED IN THE FIELD.
2. THE CONCRETE WASHOUT SIGN (SEE PAGE 6) SHALL BE INSTALLED WITHIN 10 m OF THE TEMPORARY CONCRETE WASHOUT FACILITY.



Concrete Waste Management

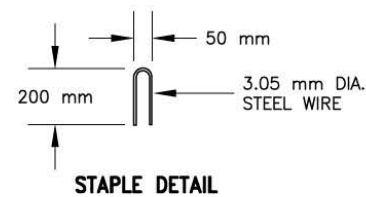
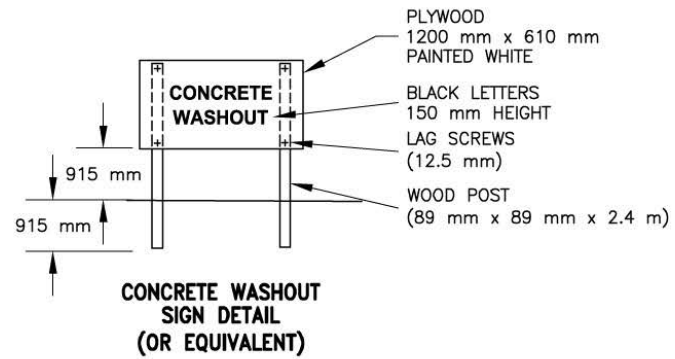
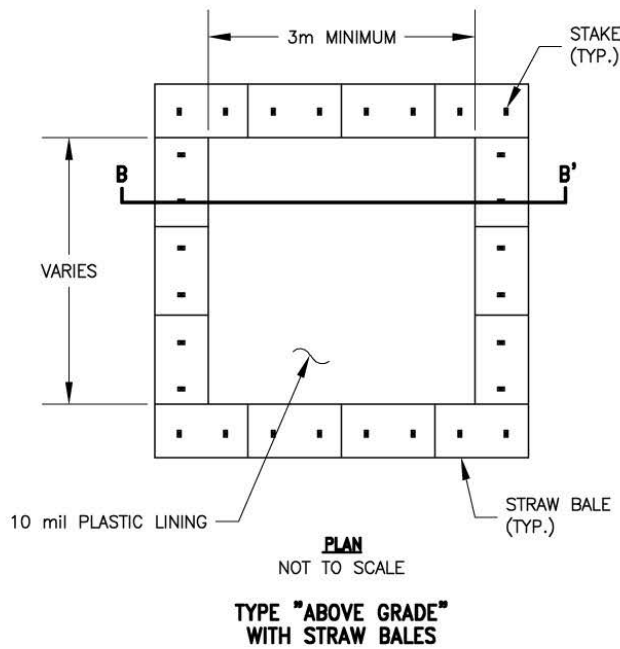
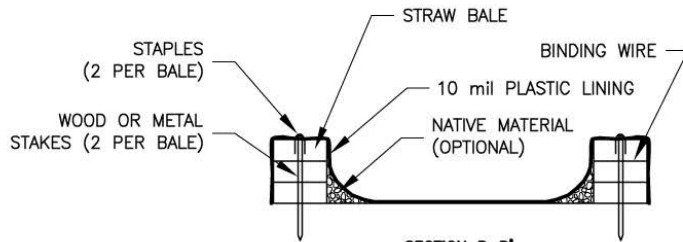

NOTES:

1. ACTUAL LAYOUT DETERMINED IN THE FIELD.
2. THE CONCRETE WASHOUT SIGN (SEE FIG. 4-15) SHALL BE INSTALLED WITHIN 10 m OF THE TEMPORARY CONCRETE WASHOUT FACILITY.

CALTRANS/FIG4-14.DWG SAC 8-14-02



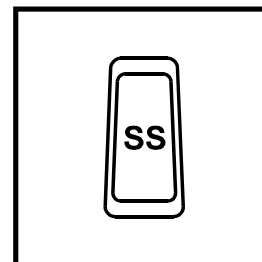
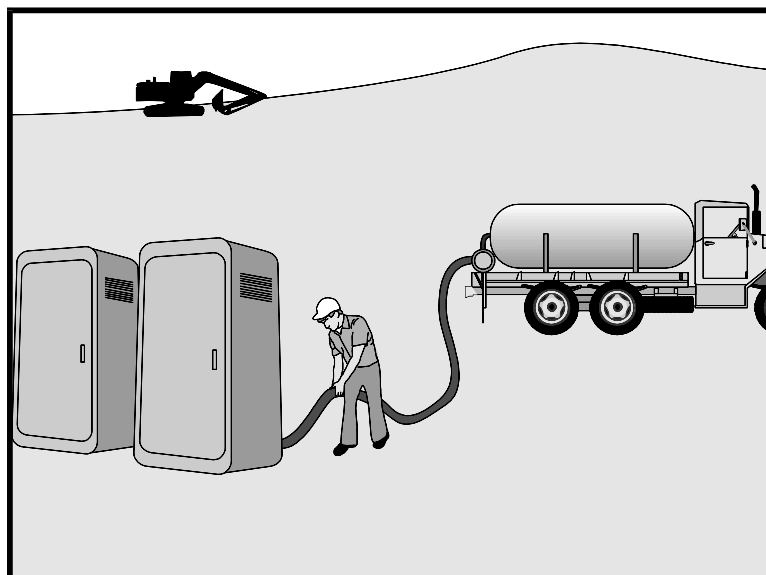

Standard Symbol

BMP Objectives

- Soil Stabilization
- Sediment Control
- Tracking Control
- Wind Erosion Control
- Non-Storm Water Management
- Materials and Waste Management

Definition and Purpose Procedures and practices to minimize or eliminate the discharge of construction site sanitary/septic waste materials to the storm drain system or to watercourses.

Appropriate Applications Sanitary/septic waste management practices are implemented on all construction sites that use temporary or portable sanitary/septic waste systems.

Limitations ■ None identified.

- Standards and Specifications**
- Education**
- Educate employees, subcontractors, and suppliers on sanitary/septic waste storage and disposal procedures.
 - Educate employees, subcontractors, and suppliers of potential dangers to humans and the environment from sanitary/septic wastes.
 - Instruct employees, subcontractors, and suppliers in identification of sanitary/septic waste.
 - Hold regular meetings to discuss and reinforce disposal procedures (incorporate into regular safety meetings).
 - Establish a continuing education program to indoctrinate new employees.

Storage and Disposal Procedures

- Temporary sanitary facilities shall be located away from drainage facilities, watercourses, and from traffic circulation. When subjected to high winds or risk.

- Wastewater shall not be discharged or buried within the highway right-of-way.
 - Sanitary and septic systems that discharge directly into sanitary sewer systems, where permissible, shall comply with the local health agency, city, county, and sewer district requirements.
 - If using an on site disposal system, such as a septic system, comply with local health agency requirements.
 - Properly connect temporary sanitary facilities that discharge to the sanitary sewer system to avoid illicit discharges.
 - Ensure that sanitary/septic facilities are maintained in good working order by a licensed service.
 - Use only reputable, licensed sanitary/septic waste haulers.
- Maintenance and Inspection
- The Contractor's Water Pollution Control Manager (WPCM) shall monitor onsite sanitary/septic waste storage and disposal procedures at least weekly.



Standard Symbol

BMP Objectives

- Soil Stabilization
- Sediment Control
- Tracking Control
- Wind Erosion Control
- Non-Storm Water Management
- Materials and Waste Management

Definition and Purpose Wood mulching consist of applying a mixture of shredded wood mulch, bark or compost. Wood mulch is mostly applicable to landscape projects.

The primary function of wood mulching is to reduce erosion by protecting bare soil from rainfall impact, increasing infiltration, and reducing runoff.

Appropriate Applications Wood mulching is considered a temporary soil stabilization (erosion control) alternative in the following situations:

- As a stand-alone temporary surface cover on disturbed areas until soils can be prepared for revegetation and permanent vegetative cover can be established.
- As short term, non-vegetative ground cover on slopes to reduce rainfall impact, decrease the velocity of sheet flow, settle out sediment and reduce wind erosion.

- Limitations**
- Wood mulch may introduce unwanted species.
 - Shredded wood does not withstand concentrated flows and is prone to sheet erosion.
 - Green material has the potential for the presence of unwanted weeds and other plant materials. Delivery system is primarily by manual labor, although pneumatic application equipment is available.

Standards and Specifications

Mulch Selection

There are many types of mulches, and selection of the appropriate type shall be based on the type of application and site conditions. Prior to use of wood mulches, there shall be concurrence with the District Landscape Architect since some mulch use on construction projects may not be compatible with planned or future projects. Selection of wood mulches by the Contractor shall comply with Standard Specifications Section 20-2.08, and must be approved by the Resident Engineer (RE).

Application Procedures

Prior to application, after existing vegetation has been removed, roughen embankment and fill areas by rolling with a punching-type roller or by track walking. The construction-application procedures for mulches vary significantly depending upon the type of mulching method specified. Two (2) methods are highlighted here:

- **Green Material:** This type of mulch is produced by recycling vegetation trimmings such as grass, shredded shrubs and trees. Methods of application are generally by hand, although pneumatic methods are available. Mulch shall be composted to kill weed seeds.
 - It can be used as a temporary ground cover with or without seeding.
 - The green material shall be evenly distributed on site to a depth of not more than 50 mm (2 in).
- **Shredded Wood:** Suitable for ground cover in ornamental or revegetated plantings.
 - Shredded wood/bark is conditionally suitable; see note under limitations.
 - Shall be distributed by hand (although pneumatic methods may be available).
 - The mulch shall be evenly distributed across the soil surface to a depth of 50 mm (2 in) to 75 mm (3 in).
- Avoid mulch placement onto the traveled way, sidewalks, lined drainage channels, sound walls, and existing vegetation.
- All material must be removed before re-starting work on the slopes.

Maintenance and Inspection

- Regardless of the mulching technique selected, the key consideration in Maintenance and Inspection is that the mulch needs to last long enough to achieve erosion-control objectives. If the mulch is applied as a stand-alone erosion control method over disturbed areas (without seed), it shall last the length of time the site will remain barren or until final re-grading and revegetation.
- Where vegetation is not the ultimate cover, such as ornamental and landscape applications of bark or wood chips, inspection and maintenance shall focus on longevity and integrity of the mulch.

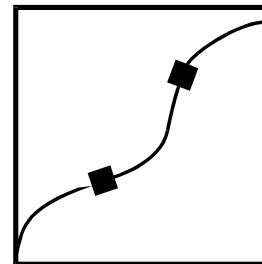
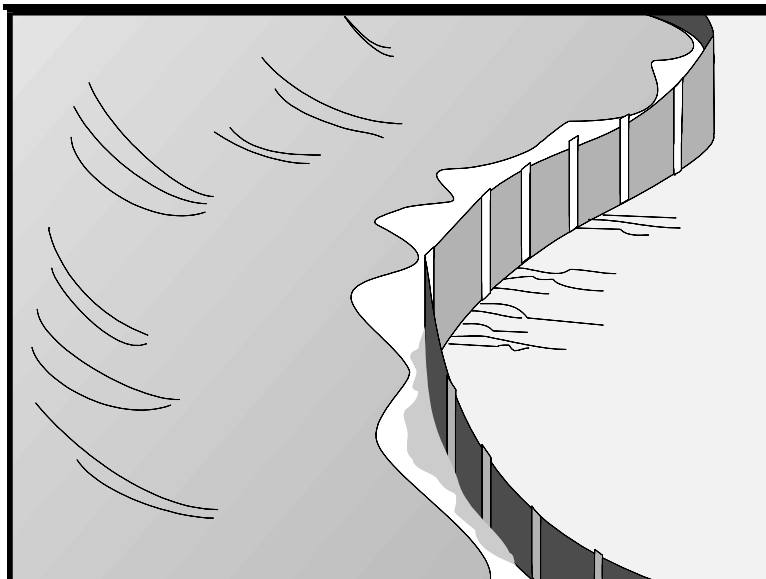

Standard Symbol

- BMP Objectives**
- Soil Stabilization
 - Sediment Control
 - Tracking Control
 - Wind Erosion Control
 - Non-Storm Water Management
 - Materials and Waste Management

Definition and Purpose A silt fence is a temporary linear sediment barrier of permeable fabric designed to intercept and slow the flow of sediment-laden sheet flow runoff. Silt fences allow sediment to settle from runoff before water leaves the construction site.

- Appropriate Applications** Silt fences are placed:
- Below the toe of exposed and erodible slopes.
 - Down-slope of exposed soil areas.
 - Around temporary stockpiles.
 - Along streams and channels.
 - Along the perimeter of a project.

- Limitations**
- Not effective unless trenched and keyed in.
 - Not intended for use as mid-slope protection on slopes greater than 1:4 (V:H).
 - Must be maintained.
 - Must be removed and disposed of.
 - Don't use below slopes subject to creep, slumping, or landslides.
 - Don't use in streams, channels, drain inlets, or anywhere flow is concentrated.
 - Don't use silt fences to divert flow.

Standards and Specifications ***Design and Layout***

- The maximum length of slope draining to any point along the silt fence shall be 61 m (200 ft) or less.
- Slope of area draining to silt fence shall be less than 1:1 (V:H).
- Limit to locations suitable for temporary ponding or deposition of sediment.
- Fabric life span generally limited to between five and eight months. Longer periods may require fabric replacement.
- Silt fences shall not be used in concentrated flow areas.
- Lay out in accordance with Pages 5 and 6 of this BMP.
- For slopes steeper than 1:2 (V:H) and that contain a high number of rocks or large dirt clods that tend to dislodge, it may be necessary to install additional protection immediately adjacent to the bottom of the slope, prior to installing silt fence. Additional protection may be a chain link fence or a cable fence.
- For slopes adjacent to water bodies or Environmentally Sensitive Areas (ESAs), additional temporary soil stabilization BMPs shall be used.

Materials

- Silt fence fabric shall be woven polypropylene with a minimum width of 900 mm (36 inches) and a minimum tensile strength of 0.45-kN. The fabric shall conform to the requirements in ASTM designation D4632 and shall have an integral reinforcement layer. The reinforcement layer shall be a polypropylene, or equivalent, net provided by the manufacturer. The permittivity of the fabric shall be between 0.1 sec^{-1} and 0.15 sec^{-1} in conformance with the requirements in ASTM designation D4491. Contractor must submit certificate of compliance in accordance with Standard Specifications Section 6-1.07.
- Wood stakes shall be commercial quality lumber of the size and shape shown on the plans. Each stake shall be free from decay, splits or cracks longer than the thickness of the stake or other defects that would weaken the stakes and cause the stakes to be structurally unsuitable.
- Bar reinforcement may be used, and its size shall be equal to a number four (4) or greater. End protection shall be provided for any exposed bar reinforcement.
- Staples used to fasten the fence fabric to the stakes shall be not less than 45 mm (1.75 inches) long and shall be fabricated from 1.57 mm (0.06 inch) or heavier wire. The wire used to fasten the tops of the stakes together when

joining two sections of fence shall be 3.05 mm (0.12 inch) or heavier wire. Galvanizing of the fastening wire is not required.

Installation

- Generally, silt fences shall be used in conjunction with soil stabilization source controls up slope to provide effective erosion and sediment control.
- Bottom of the silt fence shall be keyed-in a minimum of 150 mm (12 inches).
- Trenches shall not be excavated wider and deeper than necessary for proper installation of the temporary linear sediment barriers.
- Excavation of the trenches shall be performed immediately before installation of the temporary linear sediment barriers.
- Construct silt fences with a set-back of at least 1m (3 ft) from the toe of a slope. Where a silt fence is determined to be not practical due to specific site conditions, the silt fence may be constructed at the toe of the slope, but shall be constructed as far from the toe of the slope as practical.
- Construct the length of each reach so that the change in base elevation along the reach does not exceed 1/3 the height of the barrier; in no case shall the reach exceed 150 meters (490 ft).
- Cross barriers shall be a minimum of 1/3 and a maximum of 1/2 the height of the linear barrier.
- Install in accordance with Pages 5 and 6 of this BMP.

Maintenance and Inspection

- Repair undercut silt fences.
- Repair or replace split, torn, slumping, or weathered fabric.
- Inspect silt fence when rain is forecast. Perform necessary maintenance, or maintenance required by the Resident Engineer (RE).
- Inspect silt fence following rainfall events. Perform maintenance as necessary, or as required by the RE.
- Maintain silt fences to provide an adequate sediment holding capacity. Sediment shall be removed when the sediment accumulation reaches one-third (1/3) of the barrier height. Removed sediment shall be incorporated in the project at locations designated by the RE or disposed of outside the right-of-way in conformance with the Standard Specifications.
- Silt fences that are damaged and become unsuitable for the intended purpose, as determined by the RE, shall be removed from the site of work, disposed of outside the highway right-of-way in conformance with the Standard Specifications, and replaced with new silt fence barriers.

- Holes, depressions or other ground disturbance caused by the removal of the temporary silt fences shall be backfilled and repaired in conformance with the Standard Specifications.
- Remove silt fence when no longer needed or as required by the RE. Fill and compact post holes and anchorage trench, remove sediment accumulation, and grade fence alignment to blend with adjacent ground.

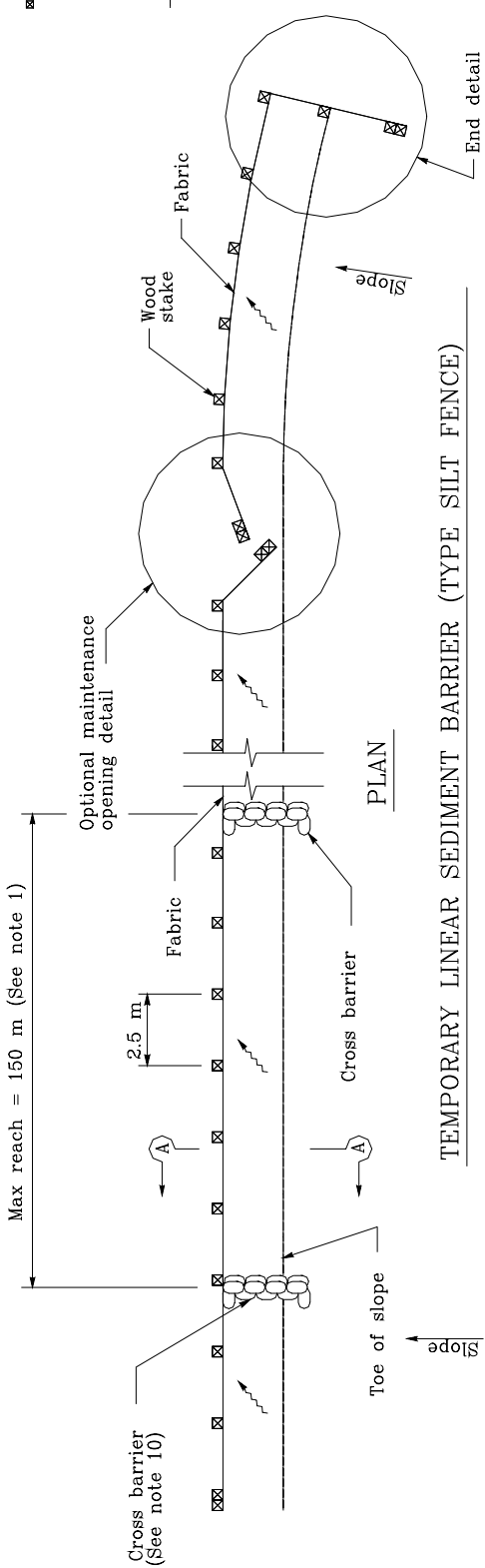

NOTES

1. Construct the length of each reach so that the change in base elevation along the reach does not exceed 1/3 the height of the linear barrier, in no case shall the reach length exceed 150m.
2. The last 2.5 m of fence shall be turned up slope.
3. Stake dimensions are nominal.
4. Dimension may vary to fit field condition.
5. Stakes shall be spaced at 2.5 m maximum and shall be positioned on downstream side of fence.
6. Stakes to overlap and fence fabric to fold around each stake one full turn. Secure fabric to stake with 4 staples.
7. Stakes shall be driven tightly together to prevent potential flow-through of sediment at joint. The tops of the stakes shall be secured with wire.
8. For end stake, fence fabric shall be folded around two stakes one full turn and secured with 4 staples.
9. Minimum 4 staples per stake. Dimensions shown are typical.
10. Cross barriers shall be a minimum of 1/3 and a maximum of 1/2 the height of the linear barrier.
11. Maintenance openings shall be constructed in a manner to ensure sediment remains behind silt fence.
12. Joining sections shall not be placed at sump locations.
13. Sandbag rows and layers shall be offset to eliminate gaps.

LEGEND

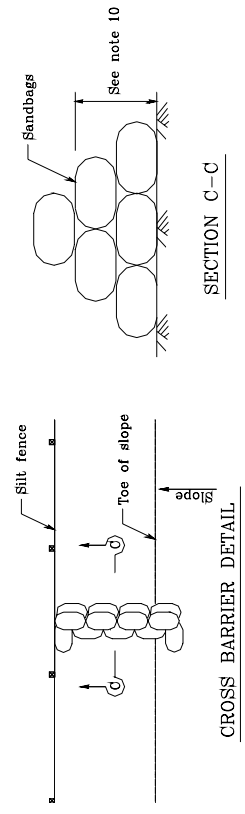
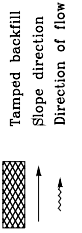

SECTION C-C

STATE OF CALIFORNIA
DEPARTMENT OF TRANSPORTATION

TEMPORARY LINEAR SEDIMENT BARRIER
(TYPE SILT FENCE)

NO SCALE

ALL DIMENSIONS ARE IN
MILLIMETERS UNLESS OTHERWISE SHOWN

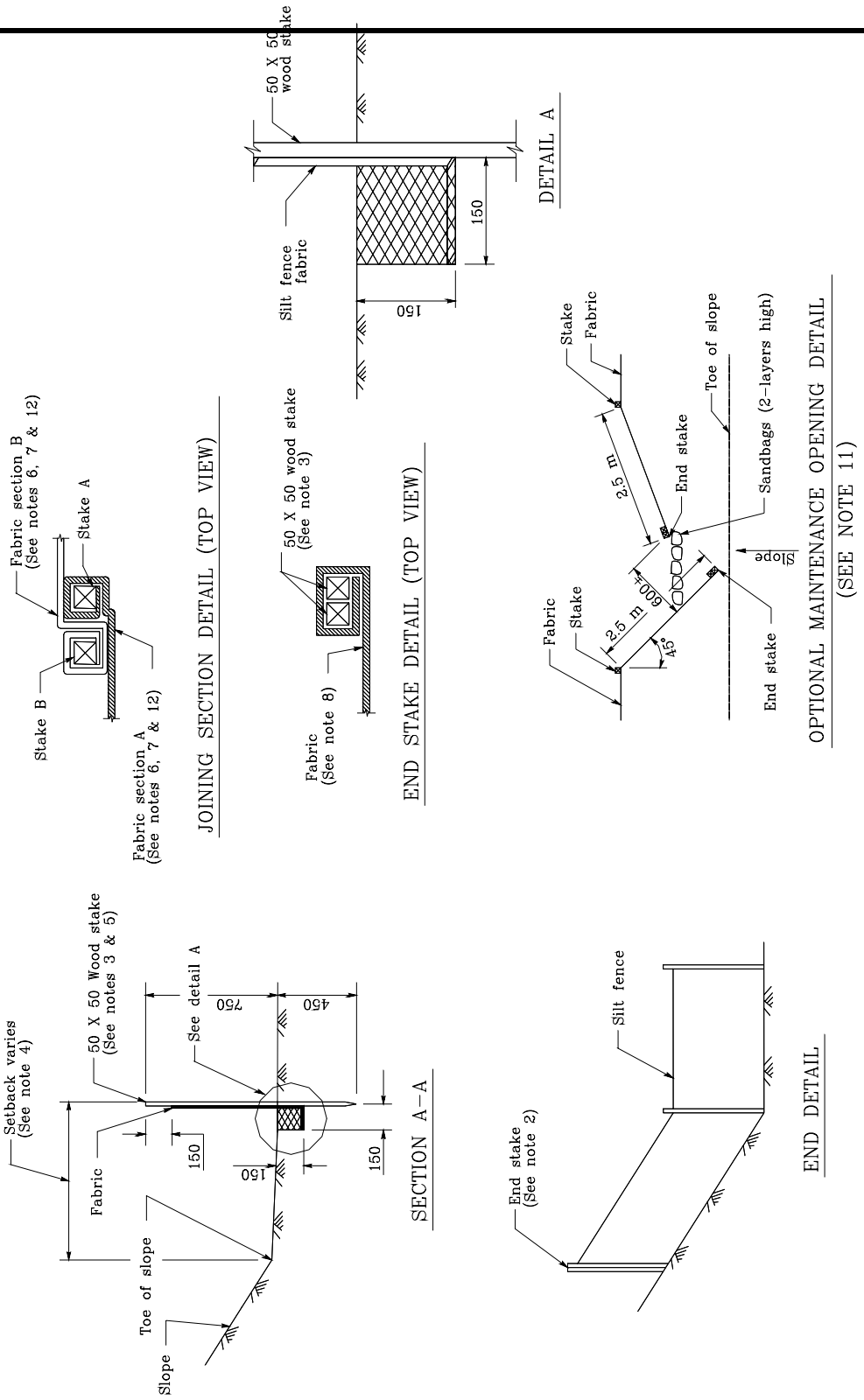

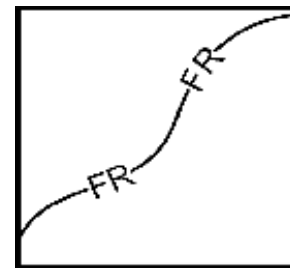

Standard Symbol

BMP Objectives

- Soil Stabilization
- Sediment Control
- Tracking Control
- Wind Erosion Control
- Non-Storm Water Management
- Materials and Waste Management

Definition and Purpose

A fiber roll consists of wood excelsior, rice or wheat straw, or coconut fibers that is rolled or bound into a tight tubular roll and placed on the toe and face of slopes to intercept runoff, reduce its flow velocity, release the runoff as sheet flow and provide removal of sediment from the runoff. Fiber rolls may also be used for inlet protection and as check dams under certain situations.

Appropriate Applications

- This BMP may be implemented on a project-by-project basis with other BMPs when determined necessary and feasible by the RE.
- Along the toe, top, face, and at grade breaks of exposed and erodible slopes to shorten slope length and spread runoff as sheet flow.
- Below the toe of exposed and erodible slopes.
- Fiber rolls may be used as check dams in unlined ditches if approved by the Resident Engineer (RE) or the District Construction Storm Water Coordinator (refer to SC-4 “Check Dams”).
- Fiber rolls may be used for drain inlet protection if approved by the RE or the District Construction Storm Water Coordinator (refer to SC-10 “Storm Drain Inlet Protection”).
- Down-slope of exposed soil areas.
- Around temporary stockpiles.
- Along the perimeter of a project.

- Limitations**
- Runoff and erosion may occur if fiber roll is not adequately trenched in.
 - Fiber rolls at the toe of slopes greater than 1:5 may require the use of 500 mm (20" diameter) or installations achieving the same protection (i.e., stacked smaller diameter fiber rolls, etc.).
 - Fiber rolls may be used for drainage inlet protection if they can be properly anchored.
 - Difficult to move once saturated.
 - Fiber rolls could be transported by high flows if not properly staked and trenched in.
 - Fiber rolls have limited sediment capture zone.
 - Do not use fiber rolls on slopes subject to creep, slumping, or landslide.

Standards and Specifications

Fiber Roll Materials

- Fiber rolls shall be either:
 - (1) Prefabricated rolls.
 - (2) Rolled tubes of erosion control blanket.

Assembly of Field Rolled Fiber Roll

- Roll length of erosion control blanket into a tube of minimum 200 mm (8 in) diameter.
- Bind roll at each end and every 1.2 m (4 ft) along length of roll with jute-type twine.

Installation

- Slope inclination of 1:4 or flatter: fiber rolls shall be placed on slopes 6.0 m apart.
- Slope inclination of 1:4 to 1:2: fiber rolls shall be placed on slopes 4.5 m apart.
- Slope inclination 1:2 or greater: fiber rolls shall be placed on slopes 3.0 m apart.
- Stake fiber rolls into a 50 to 100 mm (2 to 4 in) trench.

- Drive stakes at the end of each fiber roll and spaced 600 mm (2 ft) apart if Type 2 installation is used (refer to Page 4). Otherwise, space stakes 1.2 m (4 ft) maximum on center if installed as shown on Pages 5 and 6.
- Use wood stakes with a nominal classification of 19 by 19 mm (3/4 by 3/4 in), and minimum length of 600 mm (24 in).
- If more than one fiber roll is placed in a row, the rolls shall be overlapped; not abutted.

Removal

- Fiber rolls are typically left in place.
- If fiber rolls are removed, collect and dispose of sediment accumulation, and fill and compact holes, trenches, depressions or any other ground disturbance to blend with adjacent ground.

Maintenance and Inspection

- Repair or replace split, torn, unraveling, or slumping fiber rolls.
- Inspect fiber rolls when rain is forecast. Perform maintenance as needed or as required by the RE.
- Inspect fiber rolls following rainfall events and at least daily during prolonged rainfall. Perform maintenance as needed or as required by the RE.
- Maintain fiber rolls to provide an adequate sediment holding capacity. Sediment shall be removed when the sediment accumulation reaches three quarters (3/4) of the barrier height. Removed sediment shall be incorporated in the project at locations designated by the RE or disposed of outside the highway right-of-way in conformance with the Standard Specifications.

Fiber Rolls

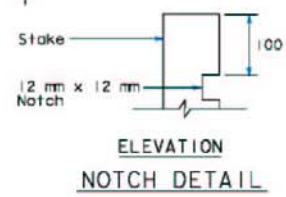
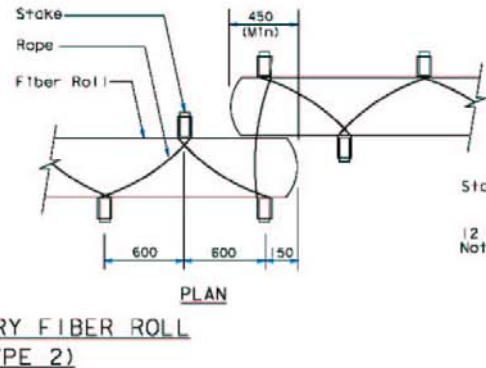
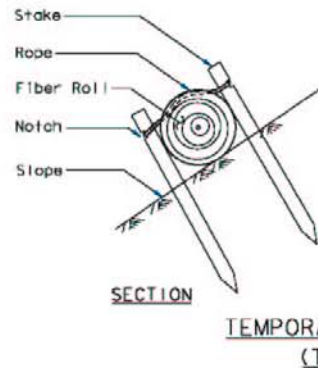
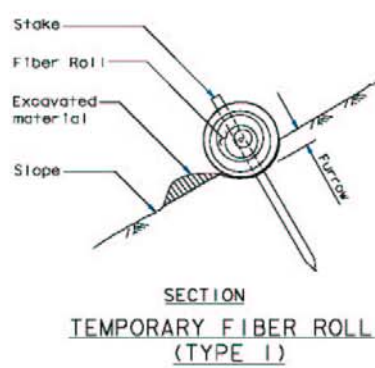

NOTE
1. Temporary fiber roll spacing varies depending upon slope inclination.

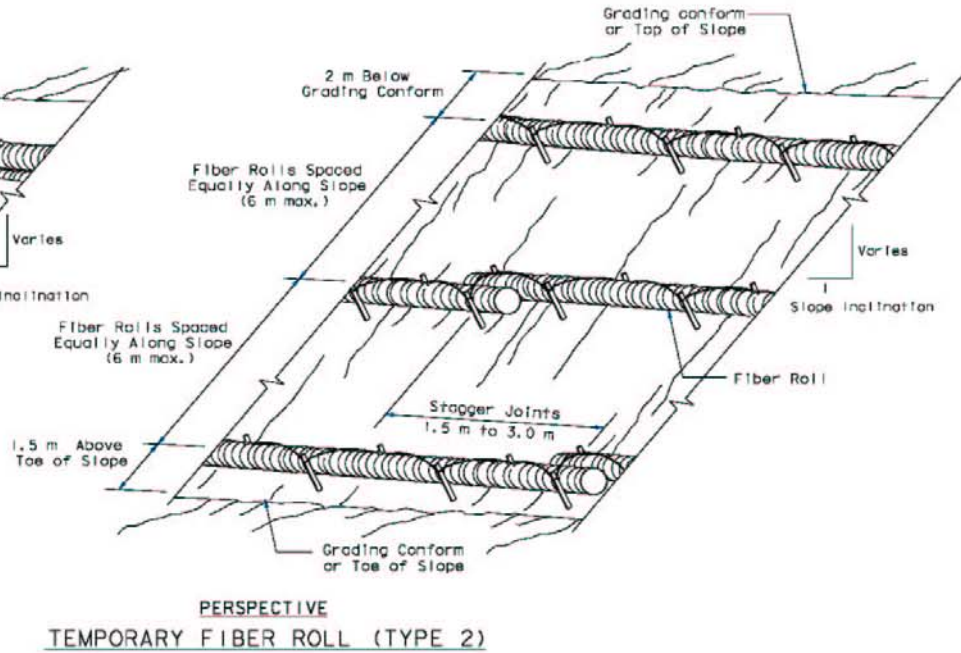
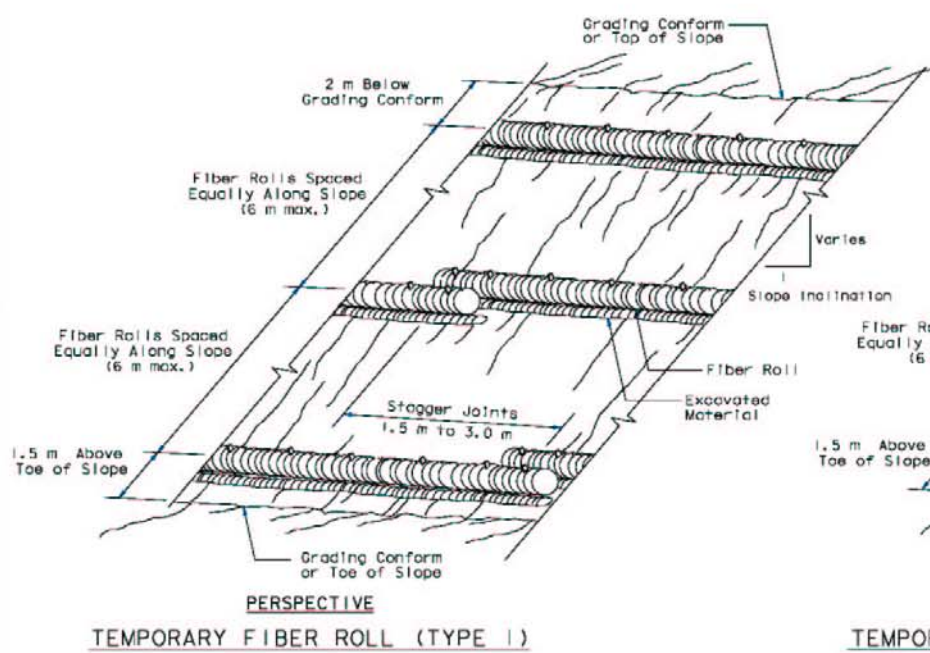

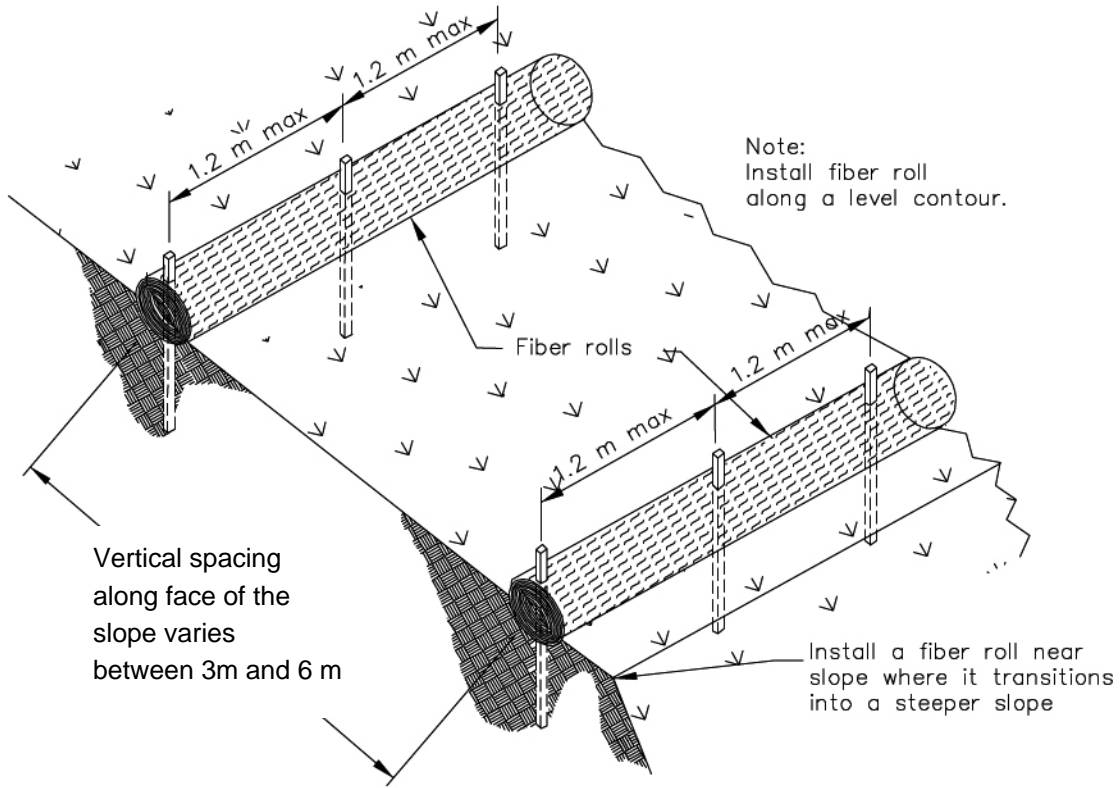

TYPICAL FIBER ROLL INSTALLATION
N.T.S.

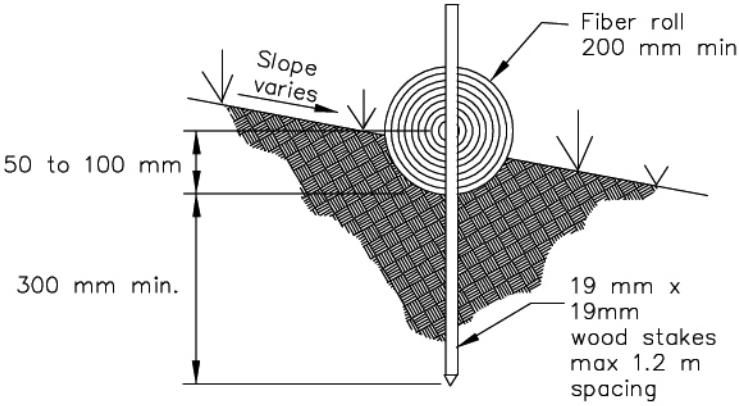

ENTRENCHMENT DETAIL
N.T.S.

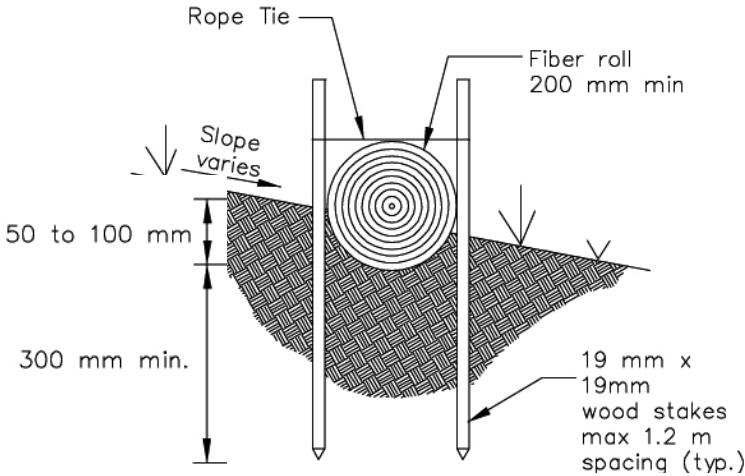
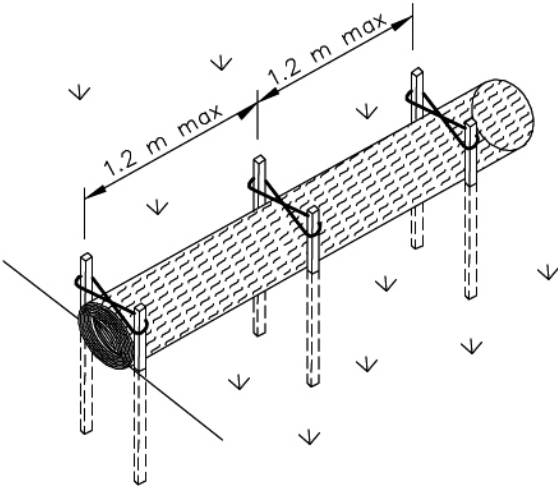

OPTIONAL ENTRENCHMENT DETAIL

N.T.S.

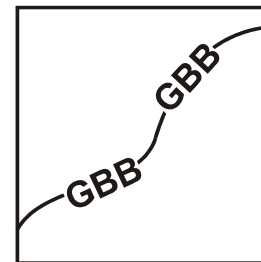
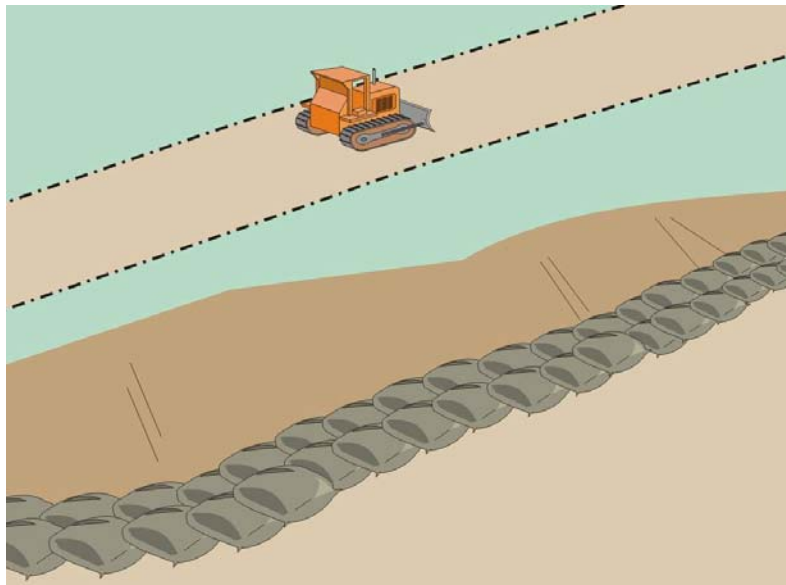

Standard Symbol

BMP Objectives

- Soil Stabilization
- Sediment Control
- Tracking Control
- Wind Erosion Control
- Non-Storm Water Management
- Materials and Waste Management

Definition and Purpose A gravel bag berm consists of a single row of gravel bags that are installed end to end to form a barrier across a slope to intercept runoff, reduce its flow velocity, release the runoff as sheet flow and provide some sediment removal. Gravel bags can be used where flows are moderately concentrated, such as ditches, swales, and storm drain inlets (see BMP SC-10, Storm Drain Inlet Protection) to divert and/or detain flows.

- Appropriate Applications**
- BMP may be implemented on a project-by-project basis with other BMPs when determined necessary and feasible by the RE.
 - Along streams and channels.
 - Below the toe of exposed and erodible slopes.
 - Down slope of exposed soil areas.
 - Around stockpiles.
 - Across channels to serve as a barrier for utility trenches or provide a temporary channel crossing for construction equipment, to reduce stream impacts.
 - Parallel to a roadway to keep sediment off paved areas.
 - At the top of slopes to divert roadway runoff away from disturbed slopes.
 - Along the perimeter of a site.
 - To divert or direct flow or create a temporary sediment basin.
 - During construction activities in stream beds when the contributing drainage

area is less than 2 ha (5 ac).

- When extended construction period limits the use of either silt fences or straw bale barriers.
- When site conditions or construction sequencing require adjustments or relocation of the barrier to meet changing field conditions and needs during construction.
- At grade breaks of exposed and erodible slopes to shorten slope length and spread runoff as sheet flow.

Limitations

- Degraded gravel bags may rupture when removed, spilling contents.
- Installation can be labor intensive.
- Limited durability for long term projects.
- When used to detain concentrated flows, maintenance requirements increase.

Standards and Specifications

Materials

- **Bag Material:** Bags shall be woven polypropylene, polyethylene or polyamide fabric, minimum unit weight 135 g/m² (four ounces per square yard), mullen burst strength exceeding 2,070 kPa (300 psi) in conformance with the requirements in ASTM designation D3786, and ultraviolet stability exceeding 70% in conformance with the requirements in ASTM designation D4355.
- **Bag Size:** Each gravel-filled bag shall have a length of 450 mm (18 in), width of 300 mm (12 in), thickness of 75 mm (3 in), and mass of approximately 15 kg (33 lb). Bag dimensions are nominal, and may vary based on locally available materials. Alternative bag sizes shall be submitted to the RE for approval prior to deployment.
- **Fill Material:** Gravel shall be between 10 mm and 20 mm (0.4 and 0.8 inch) in diameter, and shall be clean and free from clay balls, organic matter, and other deleterious materials. The opening of gravel-filled bags shall be between 13 kg and 22 kg (28 and 48 lb) in mass. Fill material is subject to approval by the RE.

Installation

- When used as a linear control for sediment removal:
 - Install along a level contour.
 - Turn ends of gravel bag row up slope to prevent flow around the ends.
 - Generally, gravel bag barriers shall be used in conjunction with temporary soil stabilization controls up slope to provide effective erosion and sediment

control.

- When used for concentrated flows:
 - Stack gravel bags to required height using a pyramid approach.
 - Upper rows of gravel bags shall overlap joints in lower rows.
- Construct gravel bag barriers with a set-back of at least 1m from the toe of a slope. Where it is determined to be not practicable due to specific site conditions, the gravel bag barrier may be constructed at the toe of the slope, but shall be constructed as far from the toe of the slope as practicable.
- Requires Certificate of Compliance per Standard Specifications 6-1.07.

Maintenance and Inspection

- Inspect gravel bag berms before and after each rainfall event, and weekly throughout the rainy season.
- Reshape or replace gravel bags as needed, or as directed by the RE.
- Repair washouts or other damages as needed, or as directed by the RE.
- Inspect gravel bag berms for sediment accumulations and remove sediments when accumulation reaches one-third of the berm height. Removed sediment shall be incorporated in the project at locations designated by the RE or disposed of outside the highway right-of-way in conformance with the Standard Specifications.
- Remove gravel bag berms when no longer needed. Remove sediment accumulations and clean, re-grade, and stabilize the area.

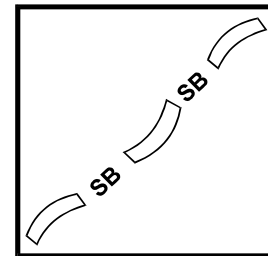
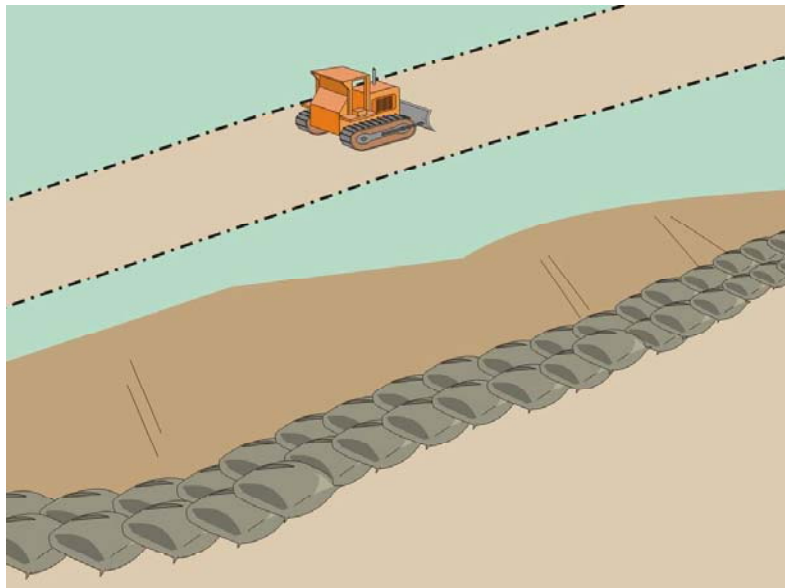

Standard Symbol

BMP Objectives

- Soil Stabilization
- Sediment Control
- Tracking Control
- Wind Erosion Control
- Non-Storm Water Management
- Materials and Waste Management

Definition and Purpose A sandbag barrier is a temporary linear sediment barrier consisting of stacked sandbags, designed to intercept and slow the flow of sediment-laden sheet flow runoff. Sandbag barriers allow sediment to settle from runoff before water leaves the construction site.

- Appropriate Applications**
- This BMP may be implemented on a project-by-project basis in addition to other BMPs when determined necessary and feasible by the Resident Engineer (RE).
 - Along the perimeter of a site.
 - Along streams and channels.
 - Below the toe of exposed and erodible slopes.
 - Down slope of exposed soil areas.
 - Around stockpiles.
 - Across channels to serve as a barrier for utility trenches or provide a temporary channel crossing for construction equipment, to reduce stream impacts.
 - Parallel to a roadway to keep sediment off paved areas.
 - At the top of slopes to divert roadway runoff away from disturbed slopes.
 - To divert or direct flow or create a temporary sediment/desilting basin.
 - During construction activities in stream beds when the contributing drainage area is less than 2 ha (5 ac).

- Appropriate Applications**
- This BMP may be implemented on a project-by-project basis in addition to other BMPs when determined necessary and feasible by the Resident Engineer (RE).
 - Along the perimeter of a site.
 - Along streams and channels.
 - Below the toe of exposed and erodible slopes.
 - Down slope of exposed soil areas.
 - Around stockpiles.
 - Across channels to serve as a barrier for utility trenches or provide a temporary channel crossing for construction equipment, to reduce stream impacts.
 - Parallel to a roadway to keep sediment off paved areas.
 - At the top of slopes to divert roadway runoff away from disturbed slopes.
 - To divert or direct flow or create a temporary sediment/desilting basin.
 - During construction activities in stream beds when the contributing drainage area is less than 2 ha (5 ac).
 - When extended construction period limits the use of either silt fences or straw bale barriers.
 - Along the perimeter of vehicle and equipment fueling and maintenance areas or chemical storage areas.
 - To capture and detain non-storm water flows until proper cleaning operations occur.
 - When site conditions or construction sequencing require adjustments or relocation of the barrier to meet changing field conditions and needs during construction.
 - To temporarily close or continue broken, damaged or incomplete curbs.
- Limitations**
- Limit the drainage area upstream of the barrier to 2 ha (5 ac).
 - Degraded sandbags may rupture when removed, spilling sand.
 - Installation can be labor intensive.
 - Limited durability for long-term projects.

- When used to detain concentrated flows, maintenance requirements increase.

Standards and Specifications

Materials

- **Sandbag Material:** Sandbag shall be woven polypropylene, polyethylene or polyamide fabric, minimum unit weight 135 g/m² (four ounces per square yard), mullen burst strength exceeding 2,070 kPa (300 psi) in conformance with the requirements in ASTM designation D3786, and ultraviolet stability exceeding 70% in conformance with the requirements in ASTM designation D4355. Use of burlap is not acceptable.
- **Sandbag Size:** Each sand-filled bag shall have a length of 450 mm (18 in), width of 300 mm (12 in), thickness of 75 mm (3 in), and mass of approximately 15 kg (33 lb.). Bag dimensions are nominal, and may vary based on locally available materials. Alternative bag sizes shall be submitted to the RE for approval prior to deployment.
- **Fill Material:** All sandbag fill material shall be non-cohesive, Class 1 or Class 2 permeable material free from clay and deleterious material, conforming to the provisions in Standard Specifications Section 68-1.025 "Permeable Material". The requirements for the Durability Index and Sand Equivalent do not apply. Fill material is subject to approval by the RE.

Installation

- When used as a linear sediment control:
 - Install along a level contour.
 - Turn ends of sandbag row up slope to prevent flow around the ends.
 - Generally, sandbag barriers shall be used in conjunction with temporary soil stabilization controls up slope to provide effective erosion and sediment control.
 - Install as shown in Pages 4 and 5 of this BMP.
- Construct sandbag barriers with a set-back of at least 1m (3 ft) from the toe of a slope. Where it is determined to be not practical due to specific site conditions, the sandbag barrier may be constructed at the toe of the slope, but shall be constructed as far from the toe of the slope as practicable.

Maintenance and Inspection

- Inspect sandbag barriers before and after each rainfall event, and weekly throughout the rainy season.

- Reshape or replace sandbags as needed, or as directed by the RE.
- Repair washouts or other damages as needed, or as directed by the RE.
- Inspect sandbag barriers for sediment accumulations and remove sediments when accumulation reaches one-third the barrier height. Removed sediment shall be incorporated in the project at locations designated by the RE or disposed of outside the highway right-of-way in conformance with the Standard Specifications.
- Remove sandbags when no longer needed. Remove sediment accumulation, and clean, re-grade, and stabilized the area.

Sandbag Barrier

SC-8

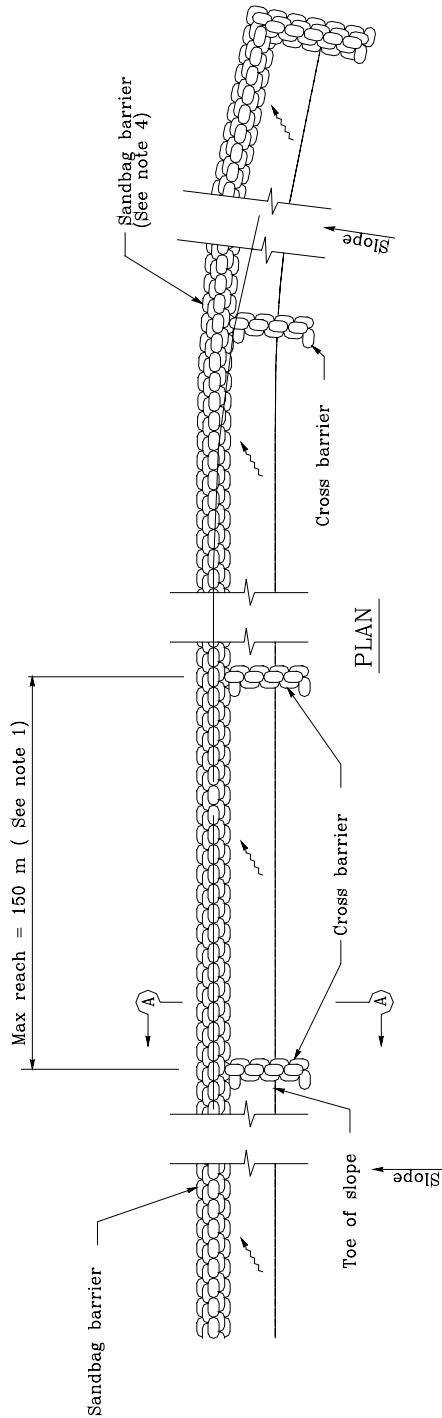

TEMPORARY LINEAR SEDIMENT BARRIER (TYPE SANDBAG)



STATE OF CALIFORNIA
DEPARTMENT OF TRANSPORTATION

TEMPORARY LINEAR SEDIMENT BARRIER (TYPE SANDBAG)

NO SCALE

ALL DIMENSIONS ARE IN
MILLIMETERS UNLESS OTHERWISE SHOWN

NOTES

1. Construct the length of each reach so that the change in base elevation along the reach does not exceed 1/2 the height of the linear barrier. In no case shall the reach length exceed 150 m.
2. Place sandbags tightly.
3. Dimension may vary to fit field condition.
4. Sandbag barrier shall be a minimum of 3 bags high.
5. The end of the barrier shall be turned up slope.
6. Cross barriers shall be a min of 1/2 and a max of 2/3 the height of the linear barrier.
7. Sandbag rows and layers shall be staggered to eliminate gaps.

Sandbag Barrier

SC-8

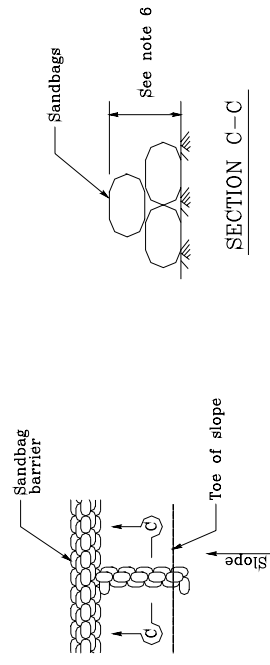
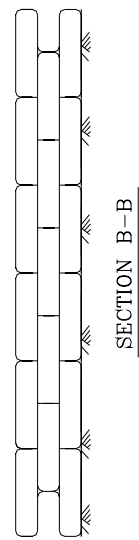
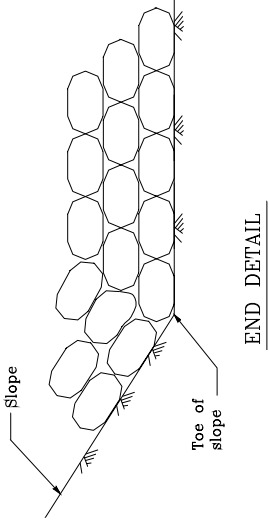
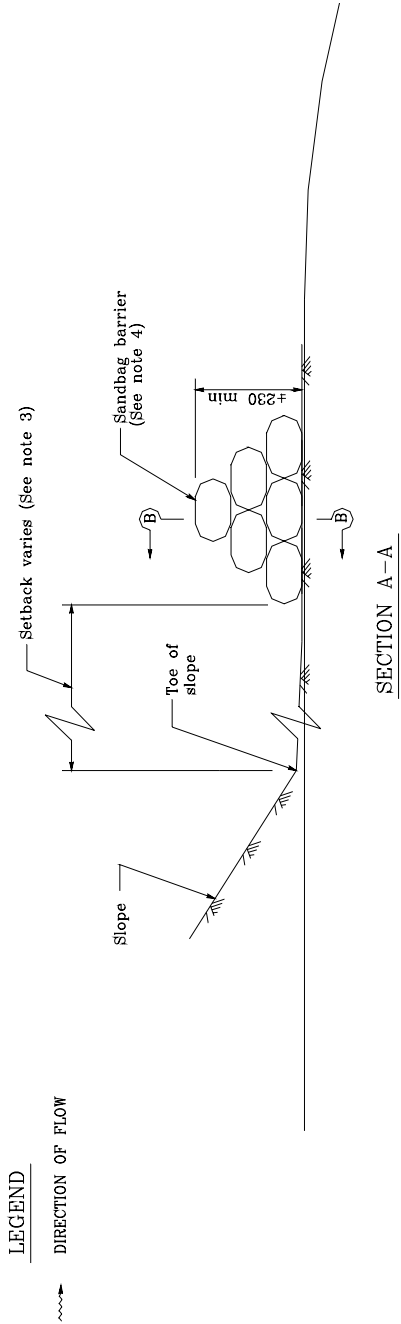

STATE OF CALIFORNIA
DEPARTMENT OF TRANSPORTATION

TEMPORARY LINEAR SEDIMENT BARRIER
(TYPE SANDBAG)

NO SCALE

ALL DIMENSIONS ARE IN MILLIMETERS UNLESS OTHERWISE SHOWN

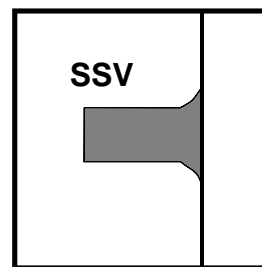

Standard Symbol

- BMP Objectives**

 - Soil Stabilization
 - Sediment Control
 - Tracking Control
 - Wind Erosion Control
 - Non-Storm Water Management
 - Materials and Waste Management

Definition and Purpose Practices to remove tracked sediment to prevent the sediment from entering a storm drain or watercourse.

Appropriate Applications These practices are implemented anywhere sediment is tracked from the project site onto public or private paved roads, typically at points of ingress/egress.

Limitations Sweeping and vacuuming may not be effective when soil is wet or muddy.

- Standards and Specifications**
- Kick brooms or sweeper attachments shall not be used.
 - Inspect potential sediment tracking locations daily.
 - Visible sediment tracking shall be swept and/or vacuumed daily.
 - If not mixed with debris or trash, consider incorporating the removed sediment back into the project.

- Maintenance and Inspection**
- Inspect ingress/egress access points daily and sweep tracked sediment as needed, or as required by the Resident Engineer (RE).
 - Be careful not to sweep up any unknown substance or any object that may be potentially hazardous.
 - Adjust brooms frequently; maximize efficiency of sweeping operations.
 - After sweeping is finished, properly dispose of sweeper wastes at an approved dumpsite in conformance with the provisions in Standard Specifications Section 7-1.13 .

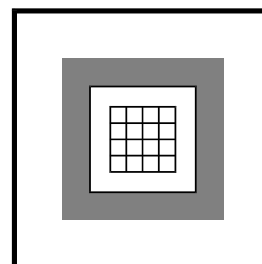
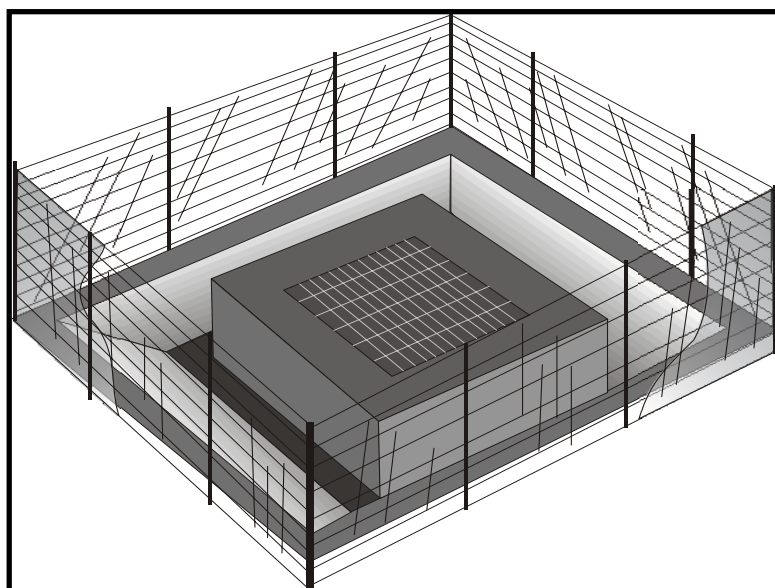

Standard Symbol

BMP Objectives

- Soil Stabilization
- Sediment Control
- Tracking Control
- Wind Erosion Control
- Non-Storm Water Management
- Materials and Waste Management

Definition and Purpose

Devices used at storm drain inlets that are subject to runoff from construction activities to detain and/or to filter sediment-laden runoff to allow sediment to settle and/or to filter sediment prior to discharge into storm drainage systems or watercourses.

Appropriate Applications

- Where ponding will not encroach into highway traffic.
- Where sediment laden surface runoff may enter an inlet.
- Where disturbed drainage areas have not yet been permanently stabilized.
- Where the drainage area is 0.4 ha (1 ac) or less.
- Appropriate during wet and snow-melt seasons.

Limitations

- Requires an adequate area for water to pond without encroaching upon traveled way and should not present itself to be an obstacle to oncoming traffic.
- May require other methods of temporary protection to prevent sediment-laden storm water and non-storm water discharges from entering the storm drain system.
- Sediment removal may be difficult in high flow conditions or if runoff is heavily sediment laden. If high flow conditions are expected, use other on-site sediment trapping techniques (e.g. check dams) in conjunction with inlet protection.
- Frequent maintenance is required.
- For drainage areas larger than 0.4 ha (1 ac), runoff shall be routed to a sediment trapping device designed for larger flows. See BMPs SC-2, "Sediment/Desilting Basin," and SC-3 "Sediment Trap."

- Filter fabric fence inlet protection is appropriate in open areas that are subject to sheet flow and for flows not exceeding 0.014 m³/s (0.5 cfs).
- Gravel bag barriers for inlet protection are applicable when sheet flows or concentrated flows exceed 0.014 m³/s (0.5 cfs), and it is necessary to allow for overtopping to prevent flooding.
- Fiber rolls and foam barriers are not appropriate for locations where they cannot be properly anchored to the surface.
- Excavated drop inlet sediment traps are appropriate where relatively heavy flows are expected and overflow capability is needed.

Standards and Specifications

Identify existing and/or planned storm drain inlets that have the potential to receive sediment-laden surface runoff. Determine if storm drain inlet protection is needed, and which method to use.

Methods and Installation

- **DI Protection Type 1 - Filter Fabric Fence** - The filter fabric fence (Type 1) protection is illustrated on Page 5. Similar to constructing a silt fence. See BMP SC-1, "Silt Fence." Do not place filter fabric underneath the inlet grate since the collected sediment may fall into the drain inlet when the fabric is removed or replaced.
- **DI Protection Type 2 - Excavated Drop Inlet Sediment Trap** - The excavated drop inlet sediment trap (Type 2) is illustrated in Page 6. Similar to constructing a temporary silt fence, See BMP SC-1, "Silt Fence." Size excavated trap to provide a minimum storage capacity calculated at the rate of 130 m³/ha (67 yd³/ac) of drainage area.
- **DI Protection Type 3 - Gravel bag** - The gravel bag barrier (Type 3) is illustrated in Page 7. Flow from a severe storm shall not overtop the curb. In areas of high clay and silts, use filter fabric and gravel as additional filter media. Construct gravel bags in accordance with BMP SC-6, "Gravel Bag Berm." Gravel bags shall be used due to their high permeability.
- **DI Protection Type 4 - Foam Barriers and Fiber Rolls** - Foam barrier or fiber roll (Type 4) is placed around the inlet and keyed and anchored to the surface. Foam barriers and fiber rolls are intended for use as inlet protection where the area around the inlet is unpaved and the foam barrier or fiber roll can be secured to the surface. RE or Construction Storm Water Coordinator approval is required.

Maintenance and Inspection

General

- Inspect all inlet protection devices before and after every rainfall event, and weekly during the rest of the rainy season. During extended rainfall events, inspect inlet protection devices at least once every 24 hours.

- Inspect the storm drain inlet after severe storms in the rainy season to check for bypassed material.
- Remove all inlet protection devices within thirty days after the site is stabilized, or when the inlet protection is no longer needed.
 - Bring the disturbed area to final grade and smooth and compact it. Appropriately stabilize all bare areas around the inlet.
 - Clean and re-grade area around the inlet and clean the inside of the storm drain inlet as it must be free of sediment and debris at the time of final inspection.

Requirements by Method

■ ***Type 1 - Filter Fabric Fence***

- This method shall be used for drain inlets requiring protection in areas where finished grade is established and erosion control seeding has been applied or is pending.
- Make sure the stakes are securely driven in the ground and are structurally sound (i.e., not bent, cracked, or splintered, and are reasonably perpendicular to the ground). Replace damaged stakes.
- Replace or clean the fabric when the fabric becomes clogged with sediment. Make sure the fabric does not have any holes or tears. Repair or replace fabric as needed or as directed by the RE.
- At a minimum, remove the sediment behind the fabric fence when accumulation reaches one-third the height of the fence or barrier height. Removed sediment shall be incorporated in the project at locations designated by the RE or disposed of outside the highway right-of-way in conformance with the Standard Specifications Section 7-1.13.

■ ***Type 2 - Excavated Drop Inlet Sediment Trap***

- This method may be used for drain inlets requiring protection in areas that have been cleared and grubbed, and where exposed soil areas are subject to grading.
- Remove sediment from basin when the volume of the basin has been reduced by one-half.

■ ***Type 3 - Gravel Bag Barrier***

- This method may be used for drain inlets surrounded by AC or paved surfaces.
- Inspect bags for holes, gashes, and snags.

- Check gravel bags for proper arrangement and displacement. Remove the sediment behind the barrier when it reaches one-third the height of the barrier. Removed sediment shall be incorporated in the project at locations designated by the RE or disposed of outside the highway right-of-way in conformance with the Standard Specifications Section 7-1.13.
- ***Type 4 Foam Barriers and Fiber Rolls***
 - This method may be used for drain inlets requiring protection in areas that have been cleared and grubbed, and where exposed soil areas subject to grading. RE or Construction Storm Coordinator approval is required.
 - Check foam barrier or fiber roll for proper arrangement and displacement. Remove the sediment behind the barrier when it reaches one-third the height of the barrier. Removed sediment shall be incorporated in the project at locations designated by the RE or disposed of outside the highway right-of-way in conformance with the Standard Specifications.

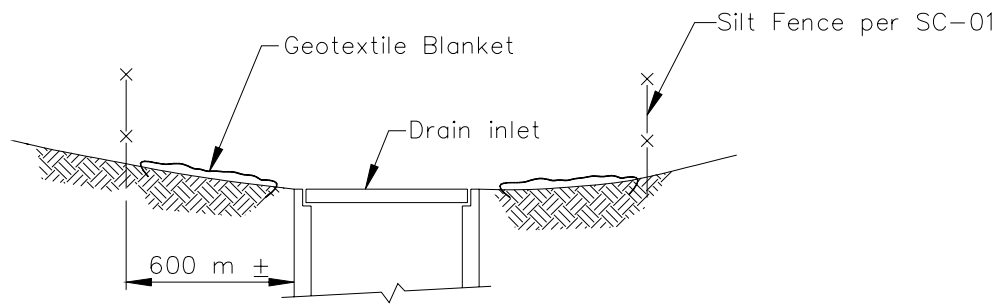

SECTION A-A

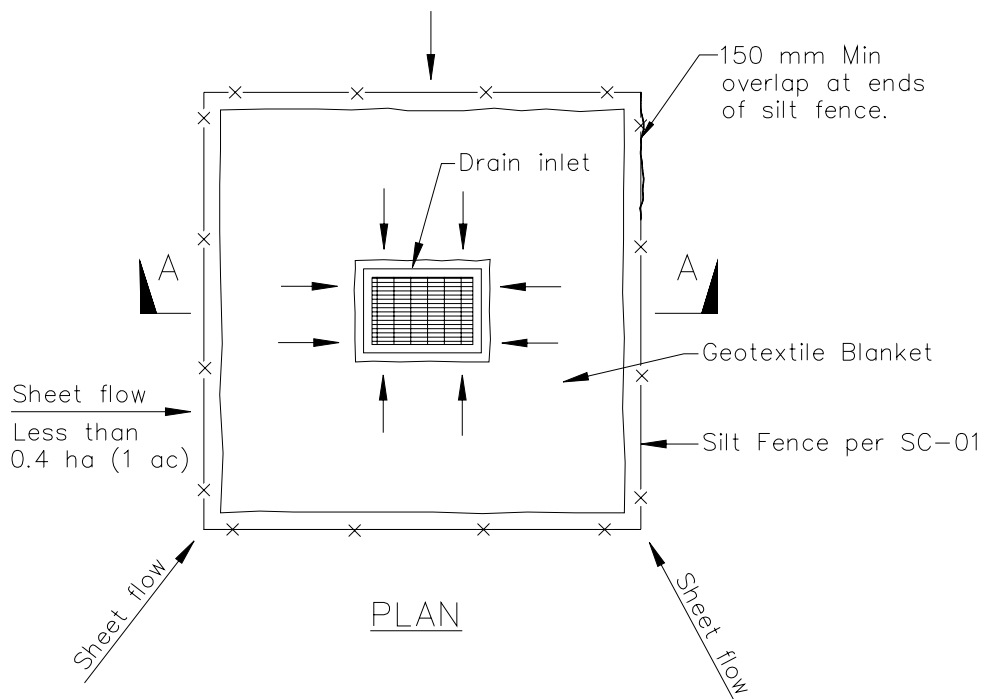

PLAN

DI PROTECTION TYPE 1
NOT TO SCALE

NOTES:

1. For use in areas where grading has been completed and final soil stabilization and seeding are pending.
2. Not applicable in paved areas.
3. Not applicable with concentrated flows.

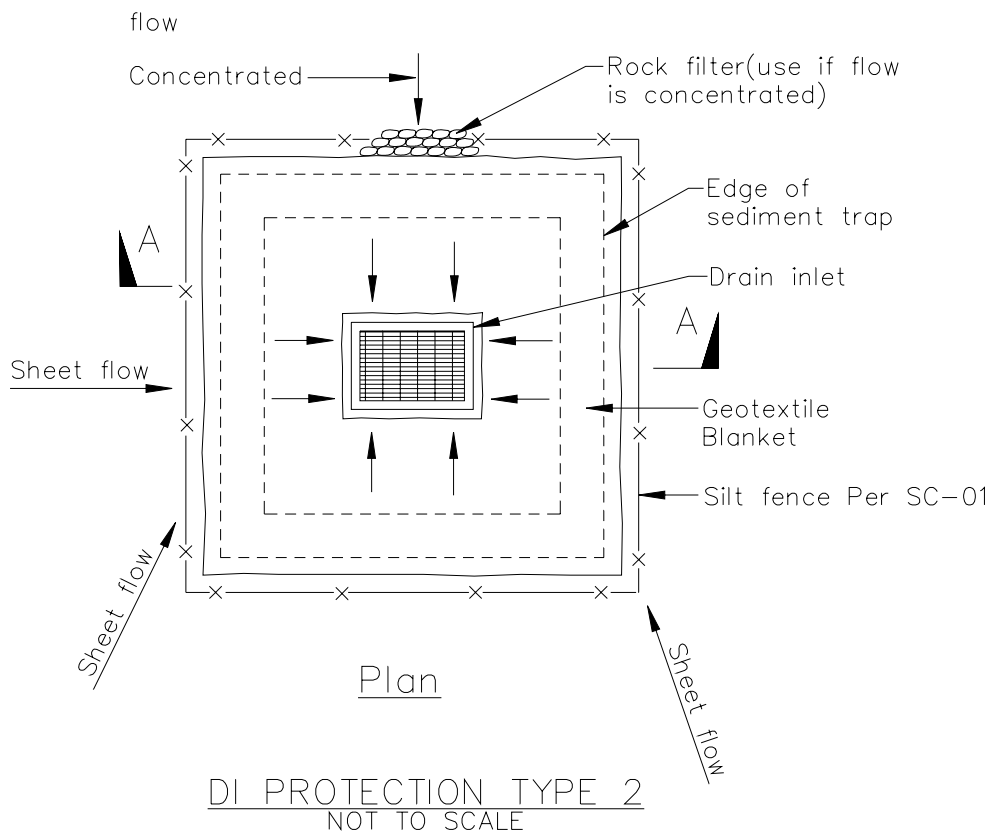
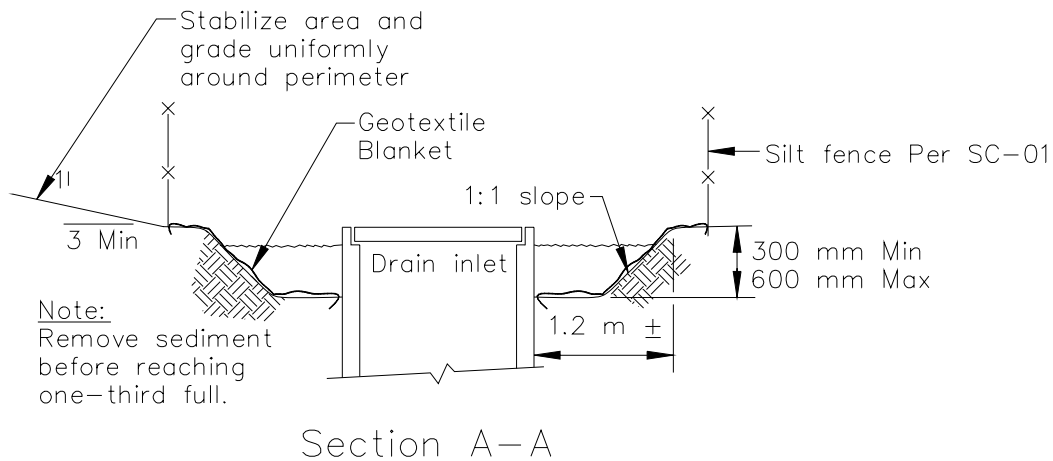

Notes

1. For use in cleared and grubbed and in graded areas.
2. Shape basin so that longest inflow area faces longest length of trap.
3. For concentrated flows, shape basin in 2:1 ratio with length oriented towards direction of flow.

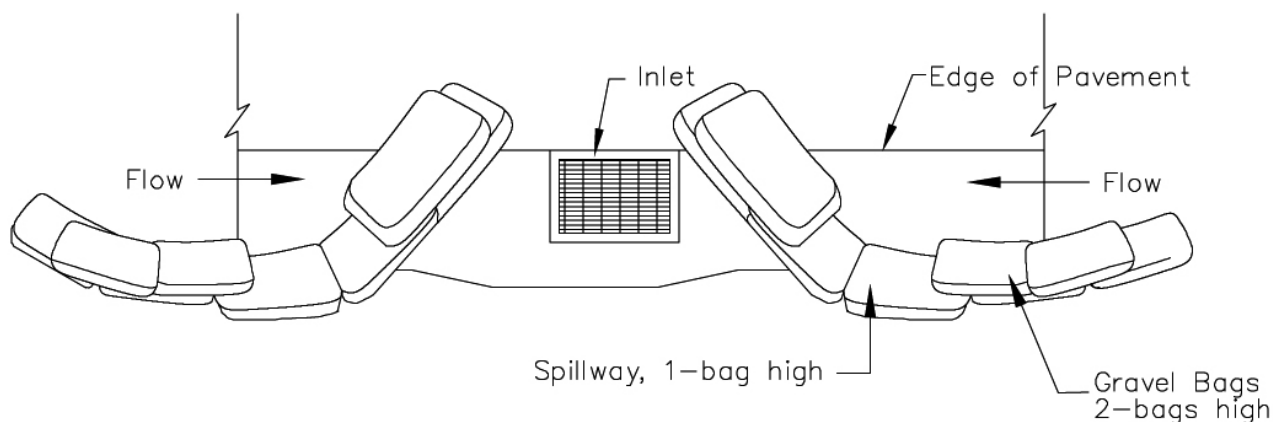

TYPICAL PROTECTION FOR INLET WITH OPPOSING FLOW DIRECTIONS

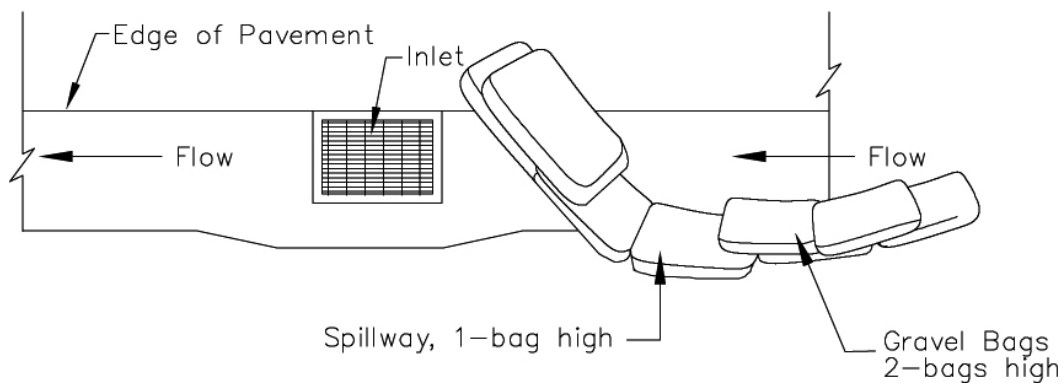

TYPICAL PROTECTION FOR INLET WITH SINGLE FLOW DIRECTION

NOTES:

1. Intended for short-term use.
2. Use to inhibit non-storm water flow.
3. Allow for proper maintenance and cleanup.
4. Bags must be removed after adjacent operation is completed
5. Not applicable in areas with high silts and clays without filter fabric.