

Private Street Fire Lane Signage

When required, approved signs, curb markings or other approved notices shall be provided for Fire Apparatus Access Roads. Their location should be shown on the approved grading, improvement or building plans. If fire lane signs are not shown, please consult with your Fire Inspector for assistance in determining sign locations.

When Required

- 24 feet street - No parking, fire lanes markings or signage required on both sides of street.
- 32 feet street- Parking allow on one side of the street. Fire lane marking or signage required on one side of the street.
- 40 feet street – Parking allowed on both sides of the street. No fire lane marking or signage required.

Signs at Entrance into Community

- Private Road, Drive and/or Easement, property owners must provide name and number of the towing company and California Vehicle Code Section on the sign.
- The tow company must have written general towing authorization agreement from said owner to remove vehicles from the property.
- A minimum of two signs shall be posted at each entrance into a private road.
- Signs required for all private streets and alleys. Signs shall be 17 inch X 22 inch in size with a thickness of .080 aluminum construction. Signs shall have white reflective background with red legend.



Signs Throughout the Community

- Fire lane sign shall be a minimum of 12 X 18 inches with a thickness of .080 aluminum construction with white reflective background and red screen-printed legend.
- Signs shall be marked, NO PARKING – FIRE LANE, along with [California Vehicle Code Section 22500.1](#). Sign shall be installed and posted every 150 feet, staggered every 75 feet on both sides of the road. Red painted curbs are acceptable in lieu of signage.
- The sign face shall have a white reflective background with a red legend. Use the standard 3M Scotchlite sign face number R7-32 or equivalent, with red screen-printed lettering as shown above.



Details and Sign Information

- All signs are to be installed perpendicular to the road and facing the direction of travel and may be required to be double sided.
- 10-foot long U-Channel galvanized or painted post.
- ¼" bolts and nuts large flat or fender washers.
- Signs must face the direction of oncoming traffic.
- Post shall be installed 12 to 18 inches from back of curb or back of sidewalk.

Breakaway Sign Post in Soil

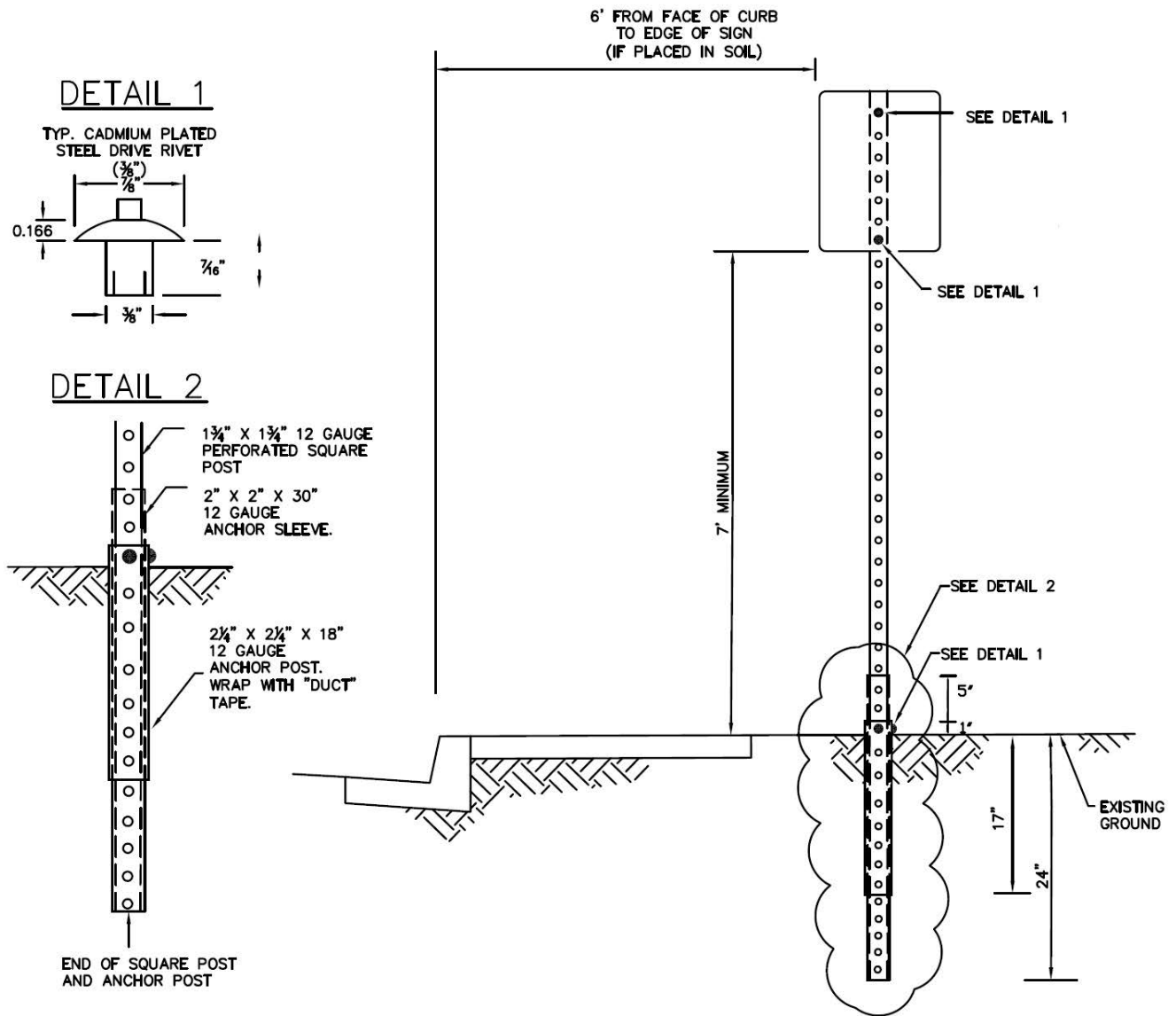

Breakaway Sign Post in Sidewalk

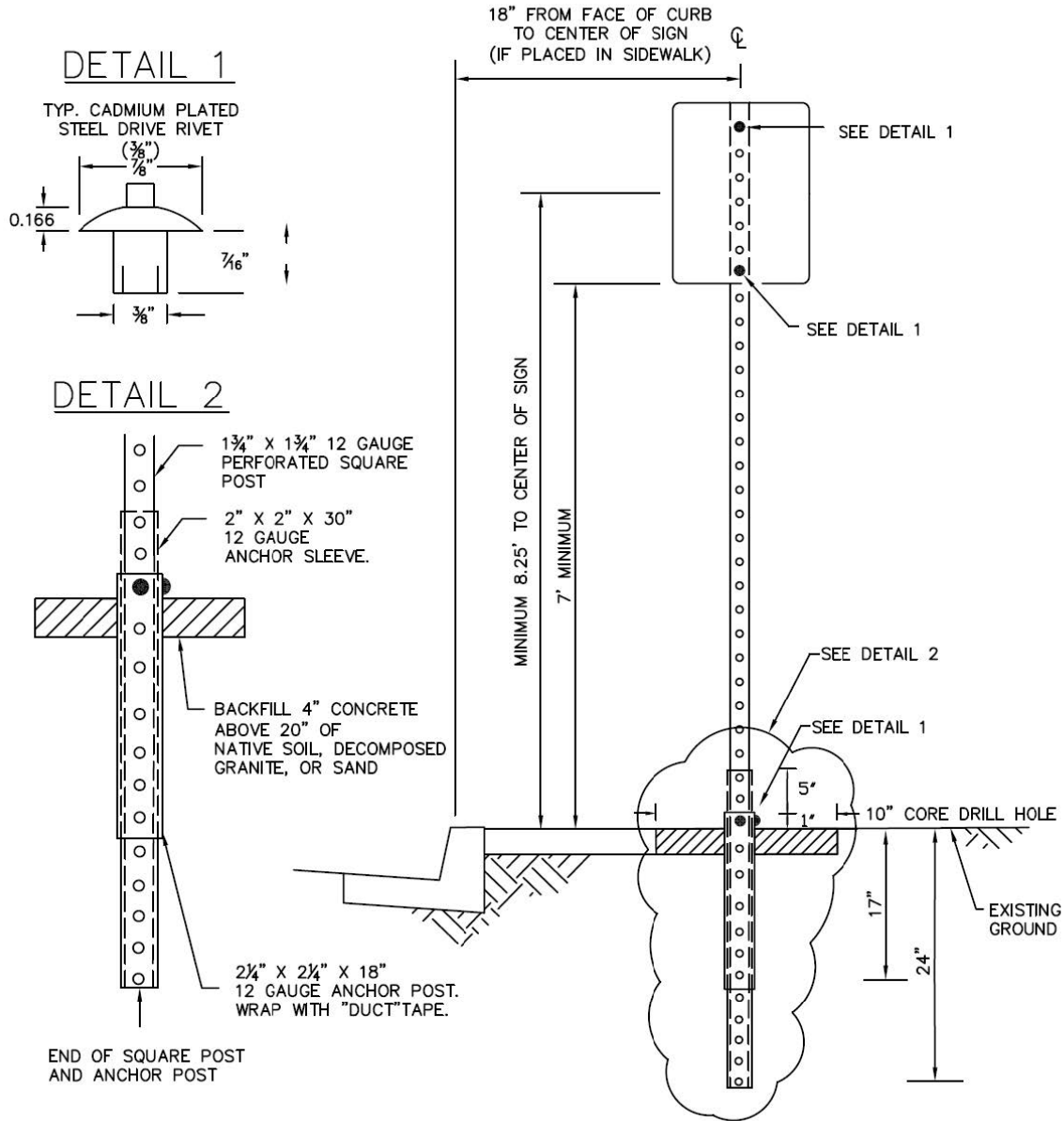

Red Curb Detail

- Stencils shall be in white lettering (4-inch height, ½ inch stroke) on “Industrial grade” safety red painted curb.
- Stencil shall read “No Parking - Fire Lane” at every 30 feet intervals.

